

# ADP-1 LINER PANEL

## ERECTION GUIDE

**BEHLEN**  
4025 E. 23rd St. • Box 569  
Columbus, Nebraska 68601

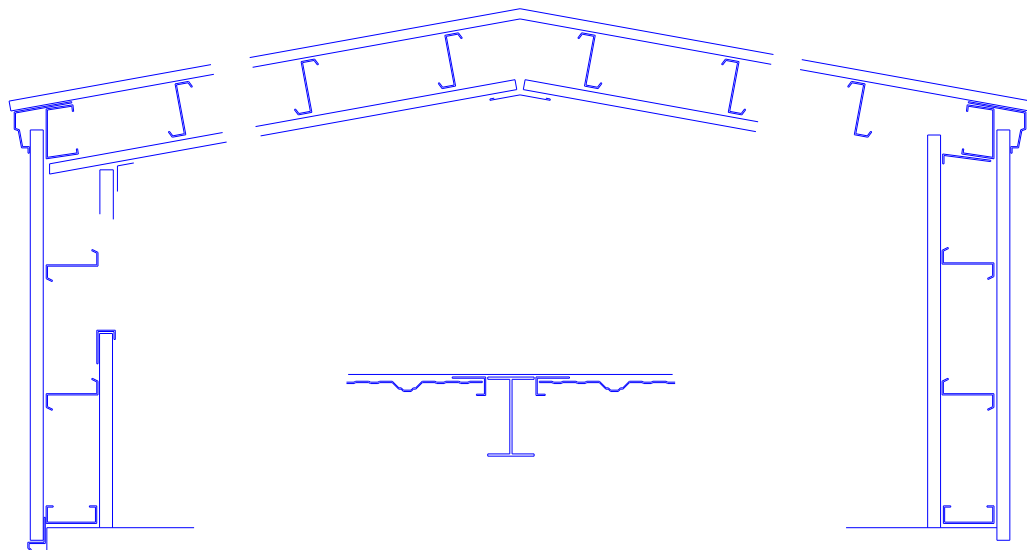

NOTE: See back side of cover for latest changes to this manual.



# FRAME BUILDING LINER TABLE OF CONTENTS

<u>TITLE OR DESCRIPTION</u>	<u>PAGE NUMBER</u>
General Information.....	2-5
Liner at Base .....	6
Liner at Girts .....	7
Liner at Eave Struts .....	8
Liner at Rake .....	9
At Columns By-Pass Girts .....	10
At Corners By-Pass Sidewall/Endwall Girts .....	11 & 12
At Columns – 1” Projection – Flush Girts .....	13
At Columns – 0” Projection – Flush Girts .....	14
At Corners Flush Girt.....	15, 16, & 17
Liner At Ceiling .....	18, 19 & 20
Liner At Self-Framing Window.....	21
Liner At Preassembled Window .....	22
Liner At Knocked-Down Door .....	23
Liner At Preassembled Door .....	24
Liner At Walk Door Rough Frame .....	25
Liner At Framed Opening .....	26 & 27
Liner At Framed Opening With Sill .....	28 & 29

## GENERAL INFORMATION

The erection information presented herein is provided as a supplement to the erection drawings prepared for your specific job. The information, illustrations and procedures in this guide are typical for most Behlen buildings. Variations may occur because of special building requirements. Always refer to the erection drawings supplied with each job which will govern specific part and assembly arrangements and applicable illustration details. Because Behlen products are constantly being improved, the information contained herein is subject to change without notice.

The following fastener schedule is to be used with this erection guide and will correspond to the fastener schedule in the erection drawings supplied with each job.

<b>FASTENER SCHEDULE</b>		
Loc.	Part No.	Description
①		As Noted On Rigid-Frame Elevation
②	3228100	Screw ¼ x ¾ FL-TP SD WW
③	3228084	Screw 12 x 1 HWH SD NW
④	3228101	Screw 12 x 1-1/4 FL-TP SD WW
⑤	3228105	Screw ¼ x 1-1/4 LG-LF SD WW
⑥	3228099	Screw 8 x ½ HWH SD NW
⑦		
⑧	3188333	Bolt ½ x 2 HVHX A325 GALV and Nut (1328191)
⑨	1328199	Bolt 5/8 x 2-1/4 HVHX A325T GALV and Nut (1328195)
⑩	1328187	Bolt ¾ x 1-1/2 HVHX A325T GALV and Nut (1328192)
⑪	1328190	Bolt ¾ x 2-1/2 HVHX A325T GALV and Nut (1328192)
⑫	3228100	Screw ¼ x ¾ FL-TP SD WW for ADP-1 Roof
	3228103	Screw ¼ x ¾ LG-LF SD WW for SSR
⑬	3228101	Screw 12 x 1-1/4 FL-TP SD WW for ADP-1 Roof
	3228105	Screw ¼ x 1-1/4 LG-LF SD WW for SSR
⑭	3228087	Screw 12 x 1-1/4 HWH SD #5PT NW
⑮	1328193	Bolt ½ x 1-1/2 HVHX A325T GALV and Nut (1328191)
⑯	3208170	Bolt ½ x 1 FLT RD HD A307 PLTD and Nut (2688007)
⑰	3228102	Screw 12 x 2 FL-TP SD WW

### Abbreviations

HD = Head  
 SD = Self-Drilling  
 ST = Self-Tapping  
 SS = Stainless Steel  
 PT = Point  
 RD = Round  
 WW = With Washer  
 NW = No Washer  
 FLT = Flat  
 HVHX = Heavy Hex  
 GALV = Galvanized  
 PLTD = Plated  
 HWH = Hex Washer Head  
 FL-TP = Flat Top  
 LG-LF = Long Life

### ERECTION INFORMATION

Liner panel sidelaps shall be stitched together with a ② fastener at 24" centers.

## GENERAL INFORMATION



### STOP . . . PLEASE READ

#### RECOMMENDED INSTALLATION FOR SELF-DRILLING TAPPING FASTENERS TO INSURE FASTENER PERFORMANCE.

\* Apply with 1800 RPM electric screw gun.

\* Drive socket size must fit appropriately to fastener head.

#### Socket Types:

1. **Super Star Socket** - Used for long-life non-magnetic screw heads. Can be used with carbon screw to avoid drill chips collecting on magnetic sockets.

Inland Part No. - 1/4" (3518045)    5/16" (3518046)    3/8" (3518047)

2. **Non-magnetic** - Used by erectors on roofing applications, mainly to avoid drill chips collecting in sockets.

Special Order - 1/4"    5/16"    3/8"

Drilling/Driving fastener must be held perpendicular to the fastening surface.

Self-Drilling fasteners should not be forced in. Allow the drill point to do the work.

### - CAUTION -

Over-torquing may result in fastener separation/failure (head popping off).

Care should be exercised during installation.

Torque of 30-60 in. lbs. Based on fastener size and application.

FOR APPLICATION SUPPORT, CONTACT:  
**ATLAS BOLT & SCREW TECHNICAL SERVICES** (800) 321-6977  
**Inland Buildings** (800) 438-1606

\*1800 RPM screw guns and sockets are available at your local tool house or from:

**Dynamic Fasteners 1-800-821-5448**

## GENERAL INFORMATION

### HANDLING LONG TRIM COMPONENTS

When removing long trims from the shipping crate and during installation, care should be taken by construction workers to avoid damage caused by buckling.

### PROTECTIVE FILM REMOVAL

The trim components received with this building have a protective film on the colored surface that must be removed prior to installation.

Prolonged exposure (more than 3 weeks) to rain and/or sunlight will adversely effect the protective film making removal difficult.

When film is being removed from trim having a hem along its edge, the film should be peeled off along the entire end. This includes the 3/8" hemmed area on the back side. Pull the entire film strip at a constant rate. Do NOT try to rip the film off as it will tend to tear at the hemmed edge and corners leaving a strip that will have to be removed separately.

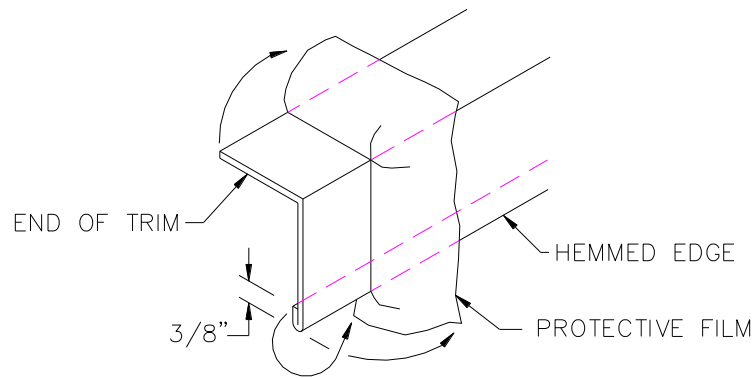

# GENERAL INFORMATION

## RELATIONSHIP OF LINER PANEL AND EXTERIOR PANEL RIBS

Liner panels for a complete sidewall or endwall surface have been detailed with a process similar to the exterior wall panels. The location of the liner panels is based on the length of the exterior wall surface and whether there is a "Start Dimension" at each end of the wall surface. This detailing process will keep the liner panel ribs and the exterior panel ribs in line.

During the erection process, the sidewall liner panel locations may start or stop at J-trims as desired but on the endwall surface, the liner panel length may be insufficient if moved to some other location.

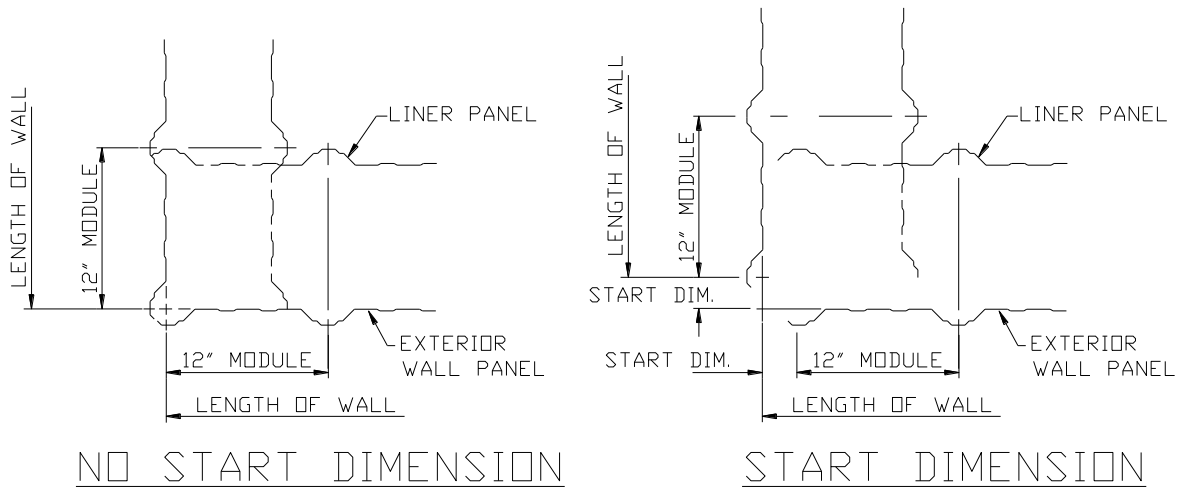

# LINER AT BASE

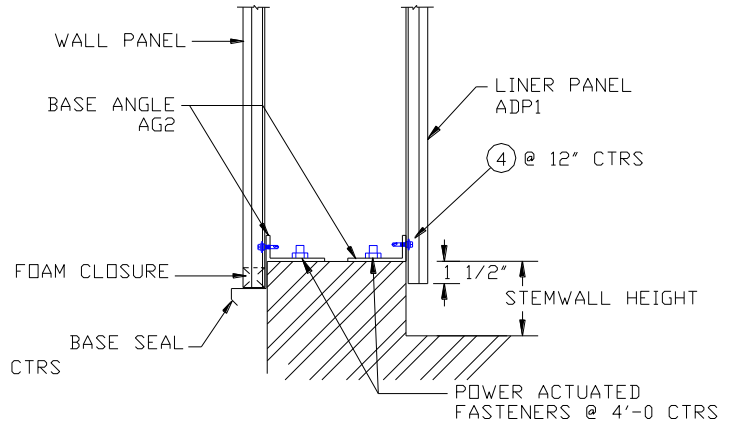
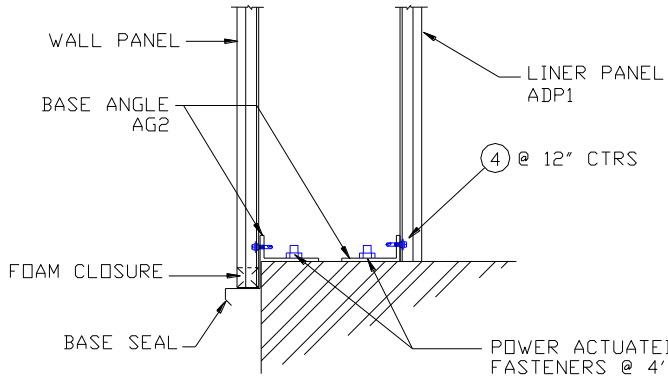

## BASE ANGLES

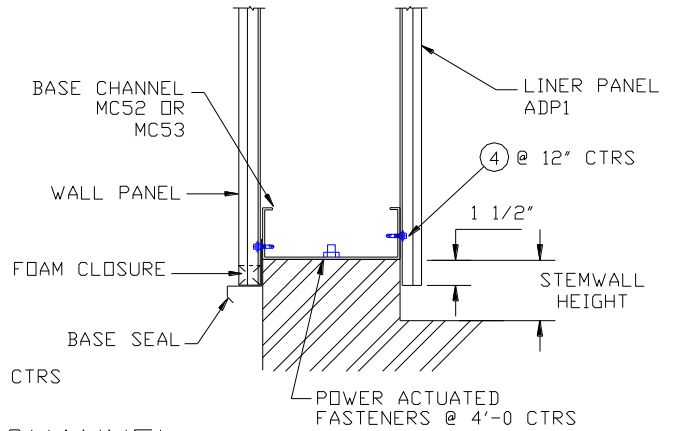
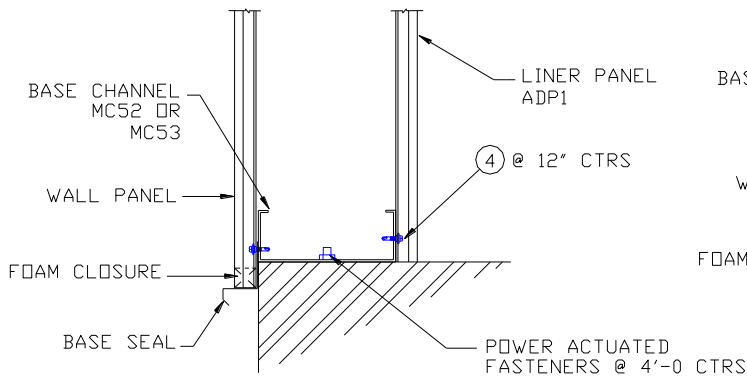

## BASE CHANNEL

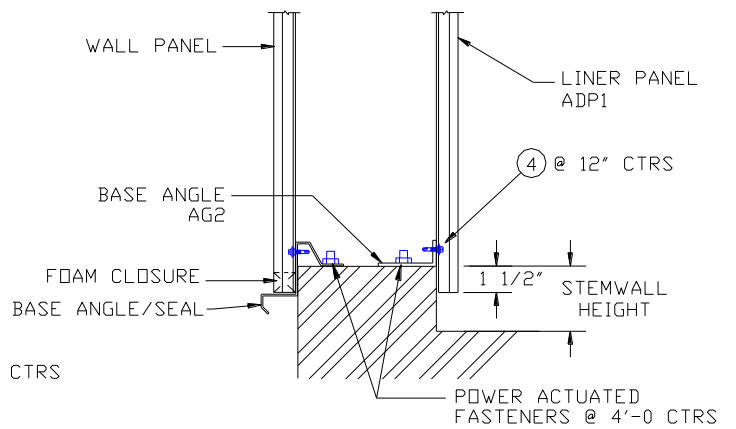
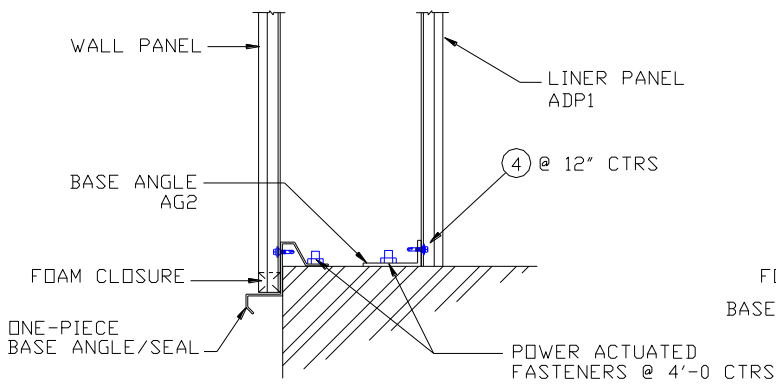

## ONE-PIECE BASE ANGLE/SEAL



# LINER AT GIRTS

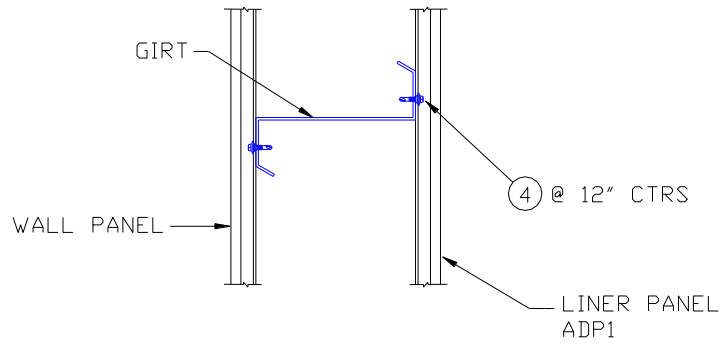

## AT GIRTS

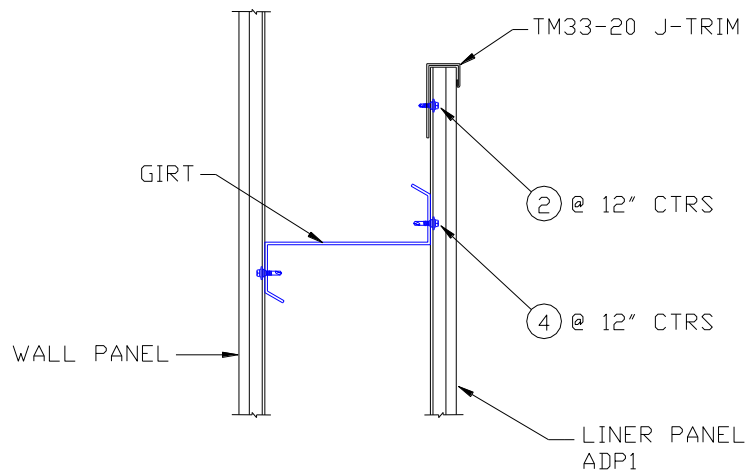

## ENDING NEAR A GIRTS

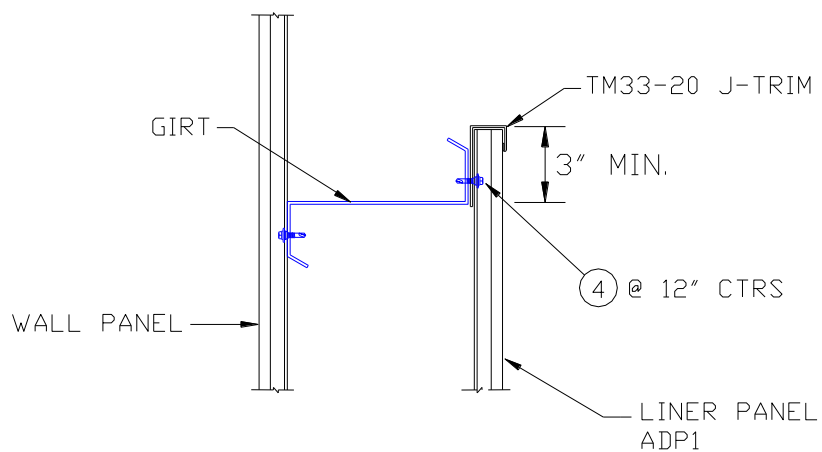

## ENDING AT A GIRTS

# LINER AT EAVE STRUT

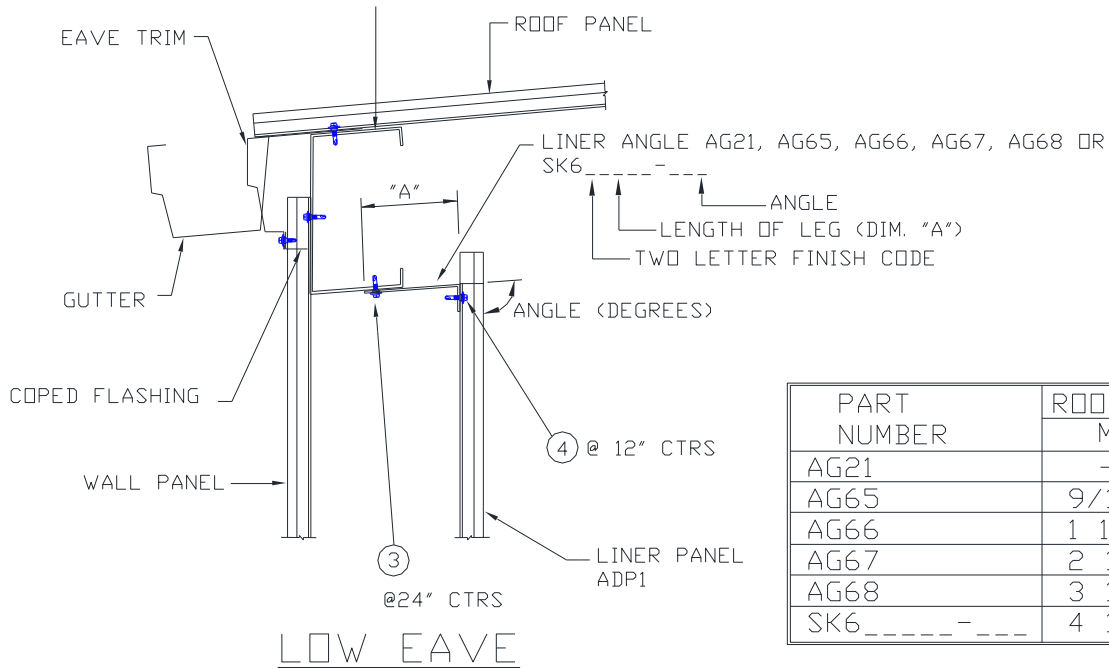

PART NUMBER	ROOF SLOPE PER 12"	
	MIN.	MAX.
AG21	--	1/2"
AG65	9/16"	1"
AG66	1 1/16"	2"
AG67	2 1/16"	3"
AG68	3 1/16"	4"
SK6_____	4 1/16"	--

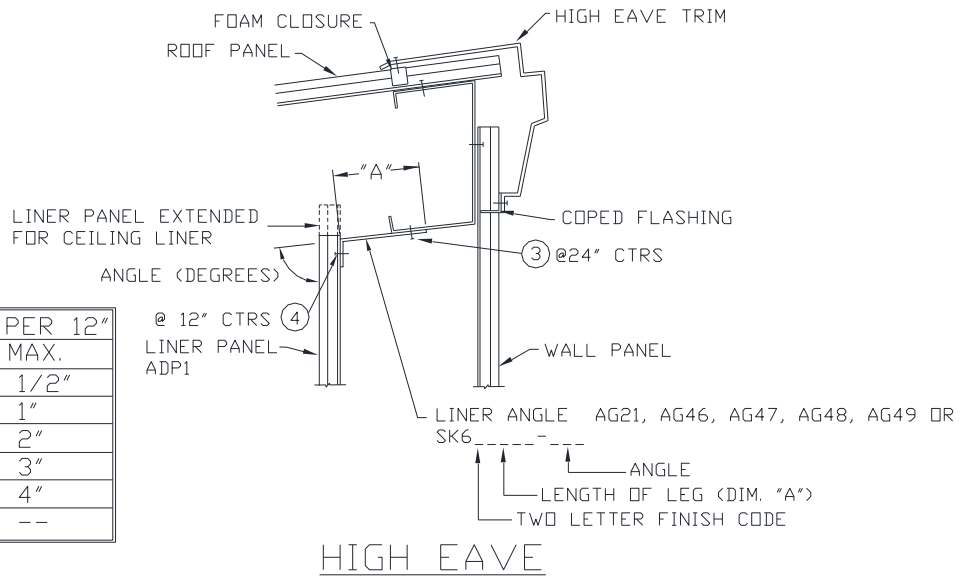

PART NUMBER	ROOF SLOPE PER 12"	
	MIN.	MAX.
AG21	--	1/2"
AG46	9/16"	1"
AG47	1 1/16"	2"
AG48	2 1/16"	3"
AG49	3 1/16"	4"
SK6_____	4 1/16"	--

# LINER AT RAKE

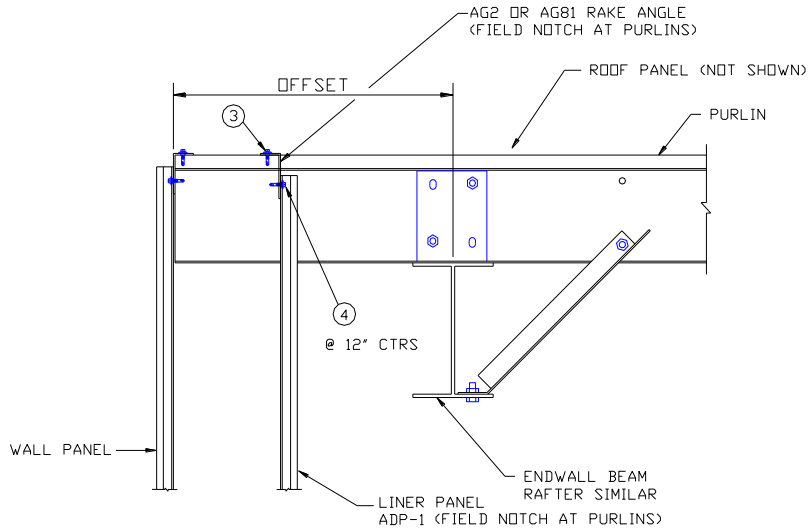

RAFTER OFFSET OF 1'-0" , 1'-2" , 1'-4" , 1'-5" , 2'-0" OR 2'-2"

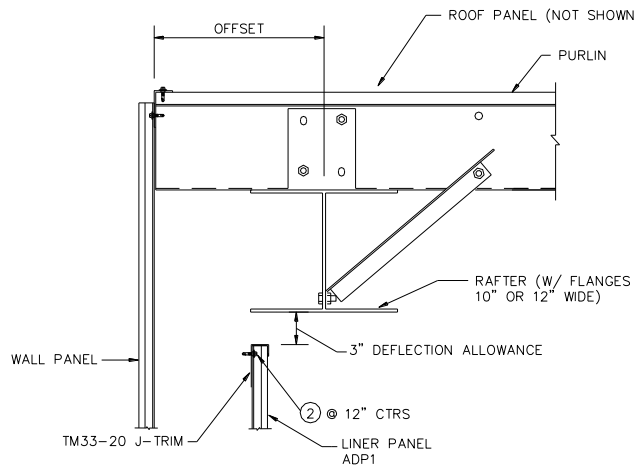

RAFTER OFFSET OF 1'-0" OR 1'-2"  
(RAFTER FLANGE WIDTHS OF 10" OR 12")

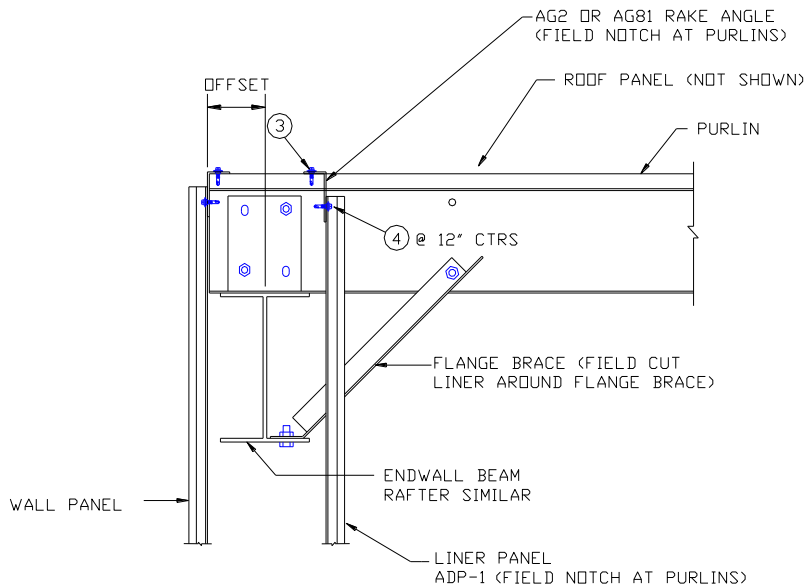

RAFTER OFFSET OF 4" OR 5"

# LINER AT COLUMNS – BY-PASS GIRTS

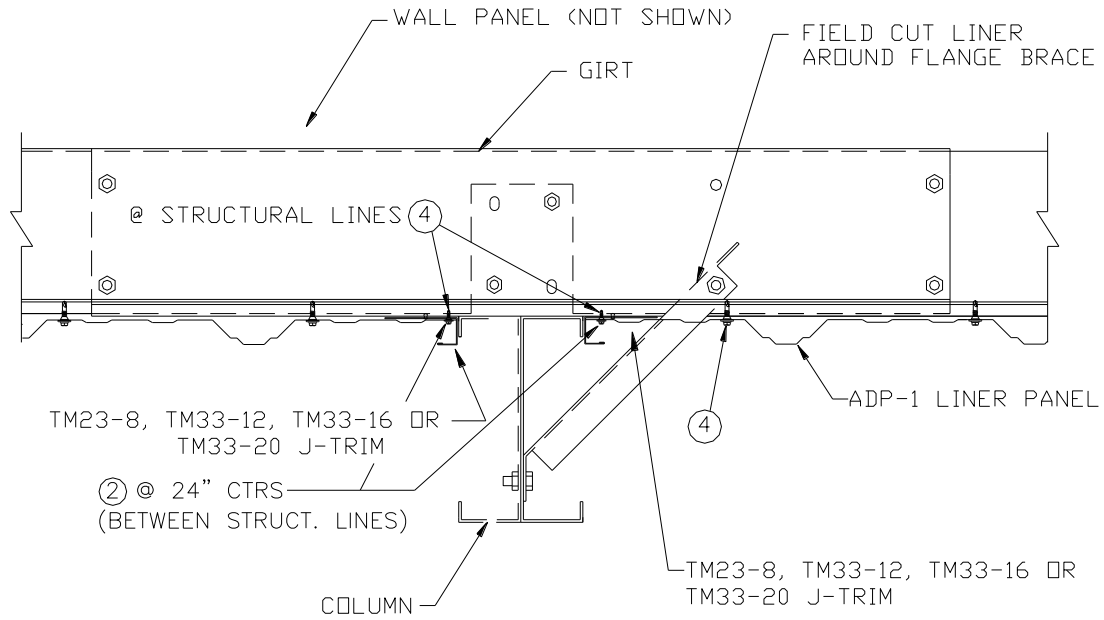

## DOUBLE CEE COLUMN (SINGLE CEE IS SIMILAR)

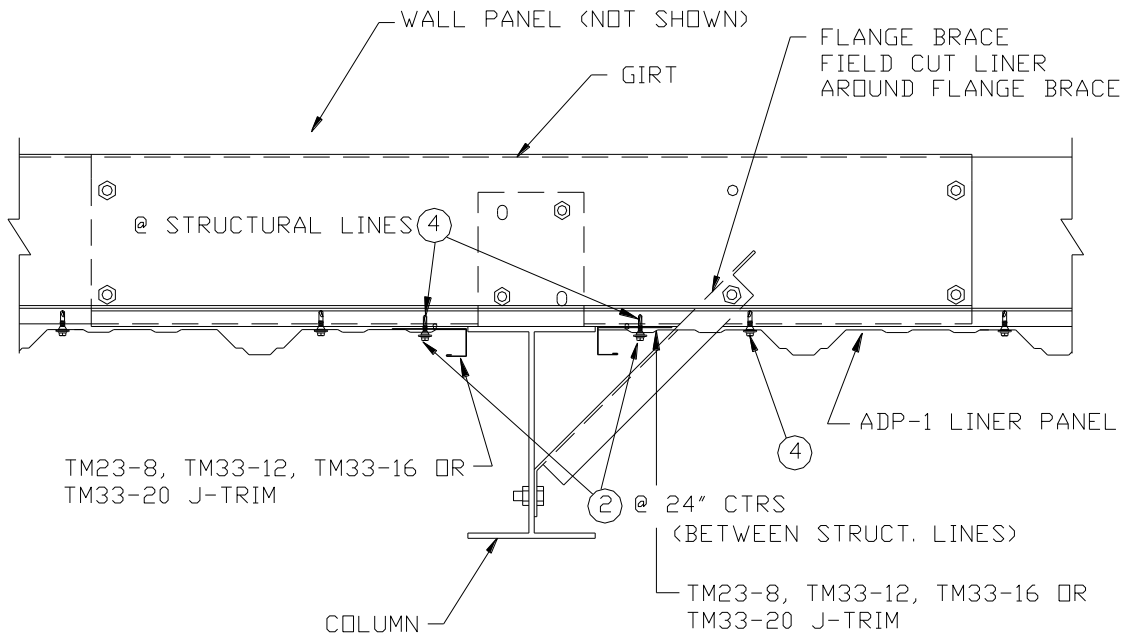

## WELDED COLUMN

# LINER AT CORNER – BY-PASS SIDEWALL/ENDWALL GIRTS

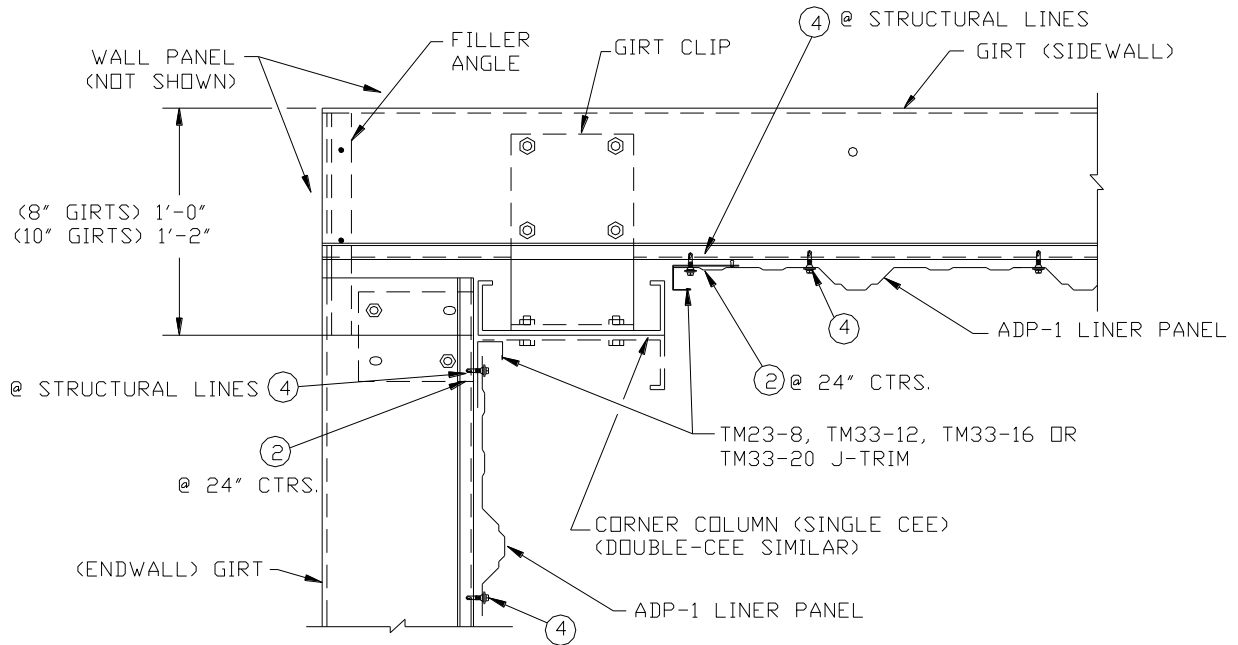

## CORNER COLUMN (SINGLE-CEE OR DOUBLE-CEE)

- BY-PASS SIDEWALL GIRT
- BY-PASS ENDWALL GIRT

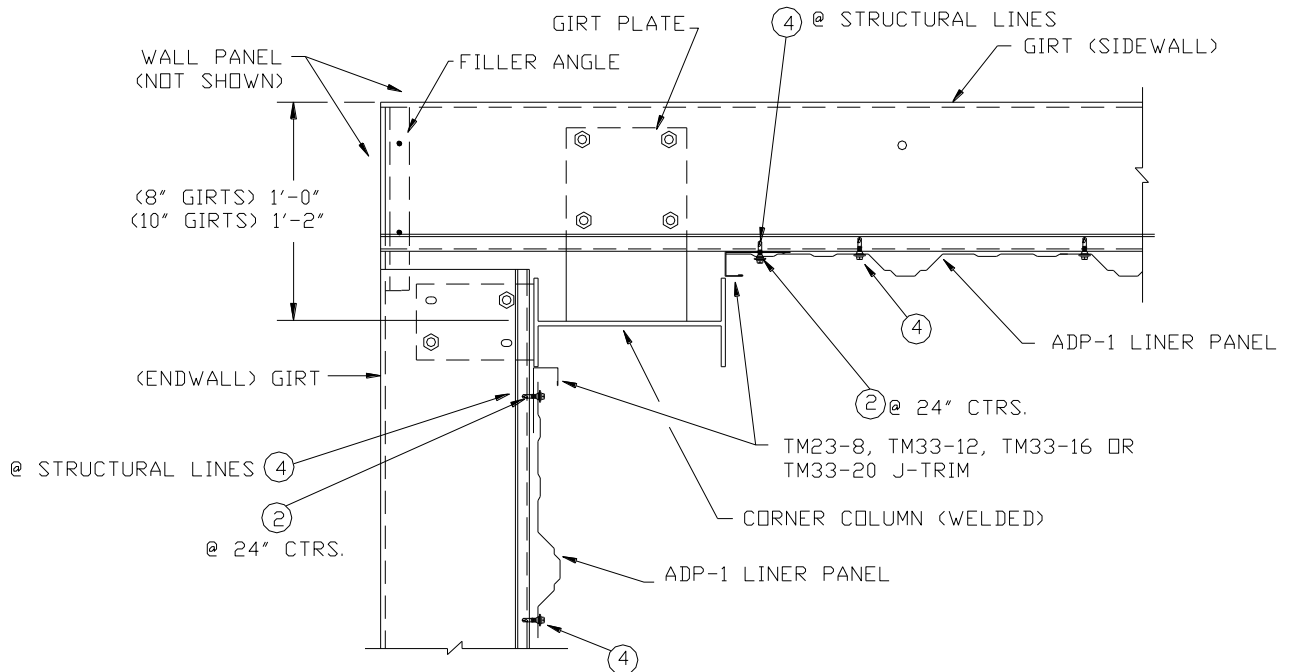

## CORNER COLUMN (WELDED OR DOUBLE-CEE)

- BY-PASS SIDEWALL GIRT
- BY-PASS ENDWALL GIRT

# LINER AT CORNER – BY-PASS SIDEWALL/ENDWALL GIRTS

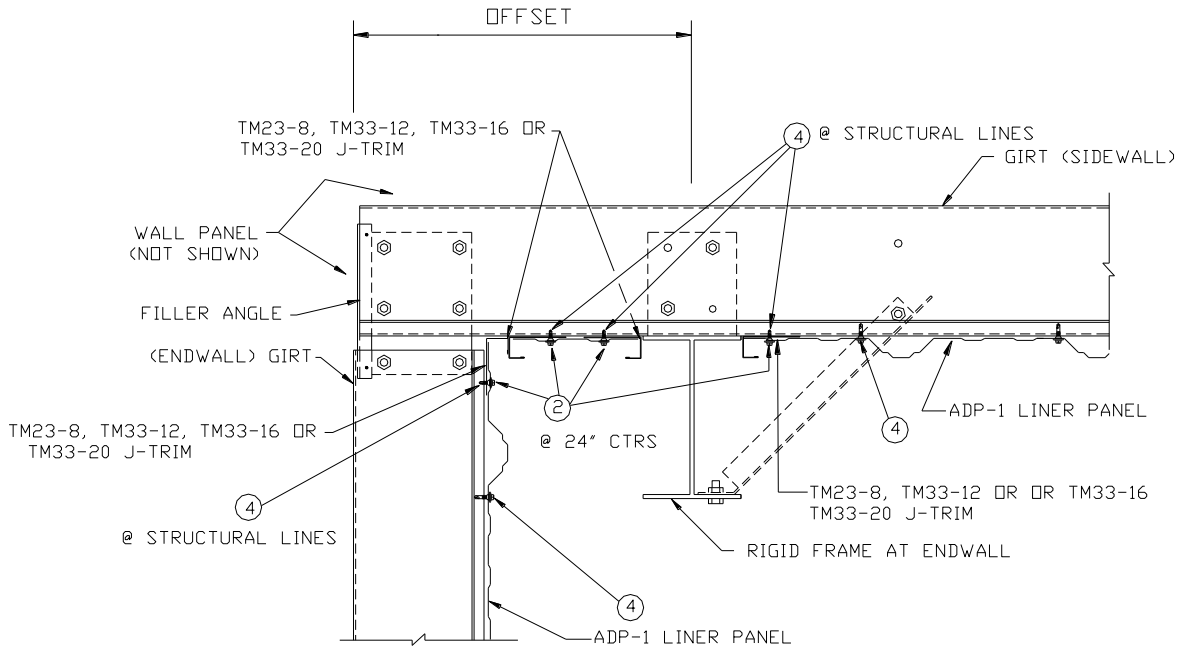

## RIGID FRAME AT ENDWALL W/1'-4" OR MORE OFFSET

- BY-PASS SIDEWALL GIRTS
- BY-PASS ENDWALL GIRTS

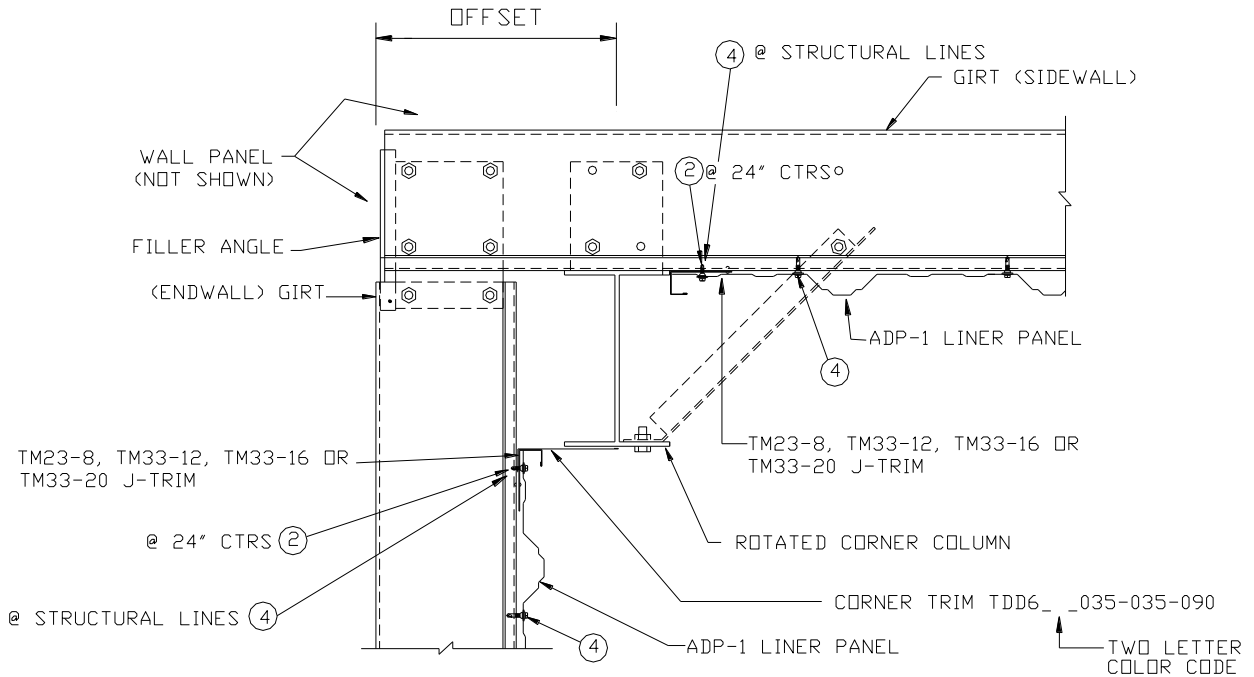

## ROTATED CORNER COLUMN W/1'-0" OR 1'-2" OFFSET

- BY-PASS SIDEWALL GIRTS
- BY-PASS ENDWALL GIRTS

# LINER AT COLUMN – 1" PROJECTION – FLUSH GIRTS

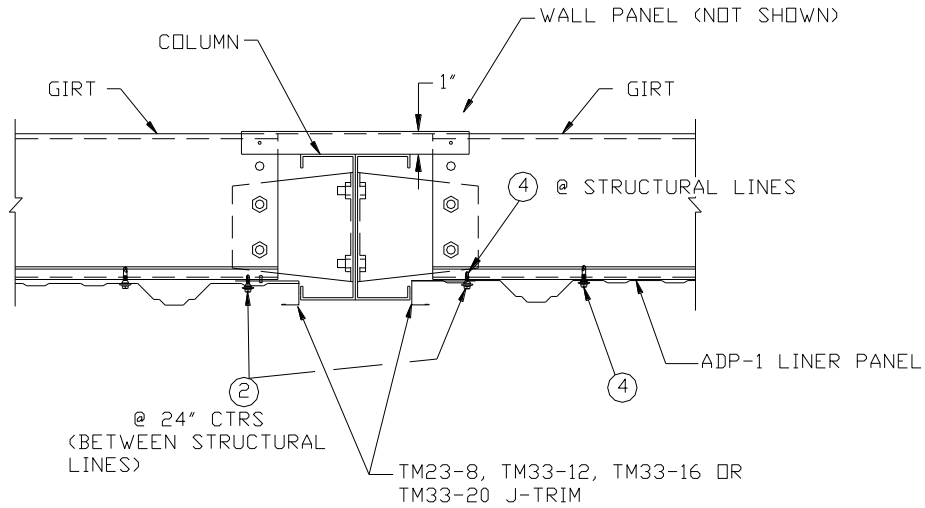

DOUBLE CEE COLUMN (SINGLE CEE IS SIMILAR)

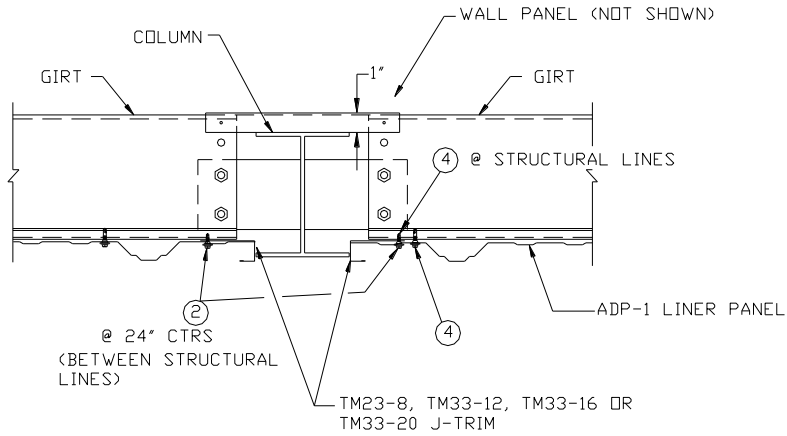

WELDED COLUMN W/DEPTH EQUAL TO GIRT DEPTH

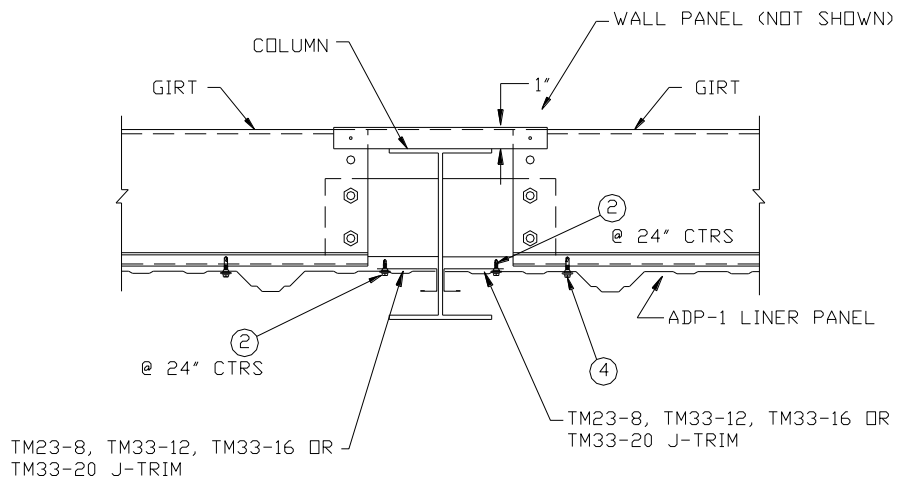

WELDED COLUMN W/DEPTH GREATER THAN GIRT DEPTH

# LINER AT COLUMN - 0" PROJECTION - FLUSH GIRTS

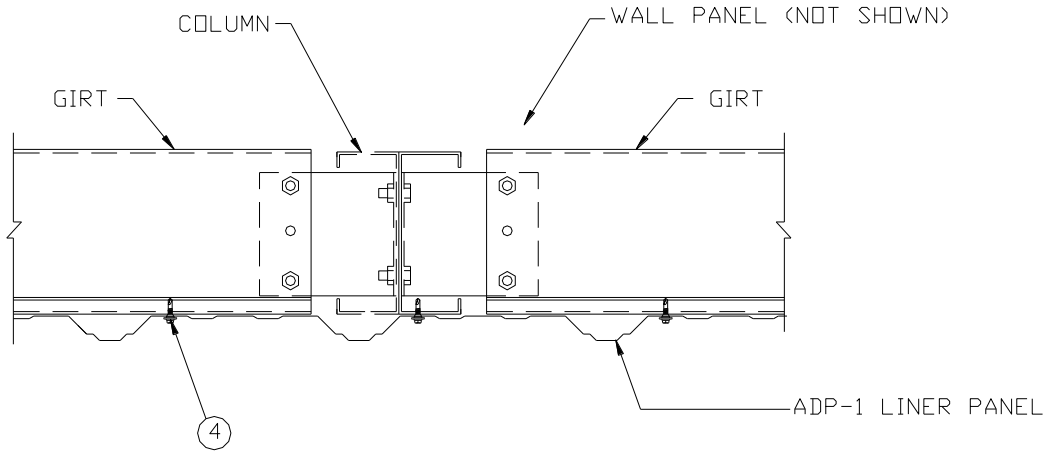

## SINGLE OR DOUBLE CEE COLUMNS

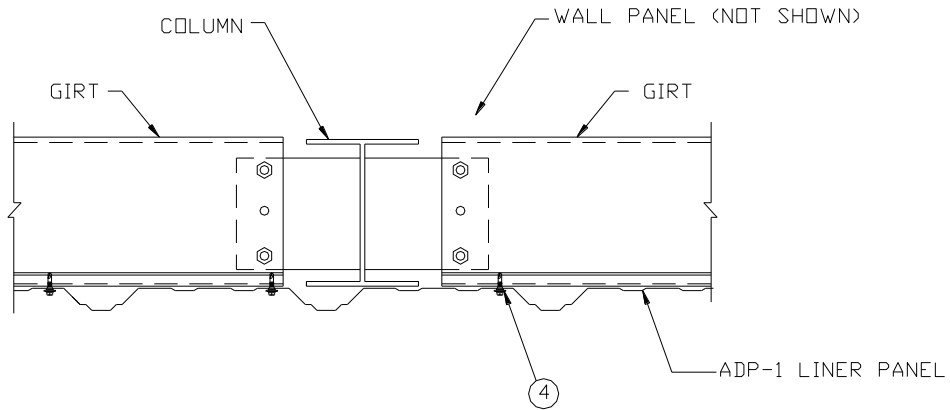

## WELDED COLUMN W/DEPTH EQUAL TO GIRTS DEPTH

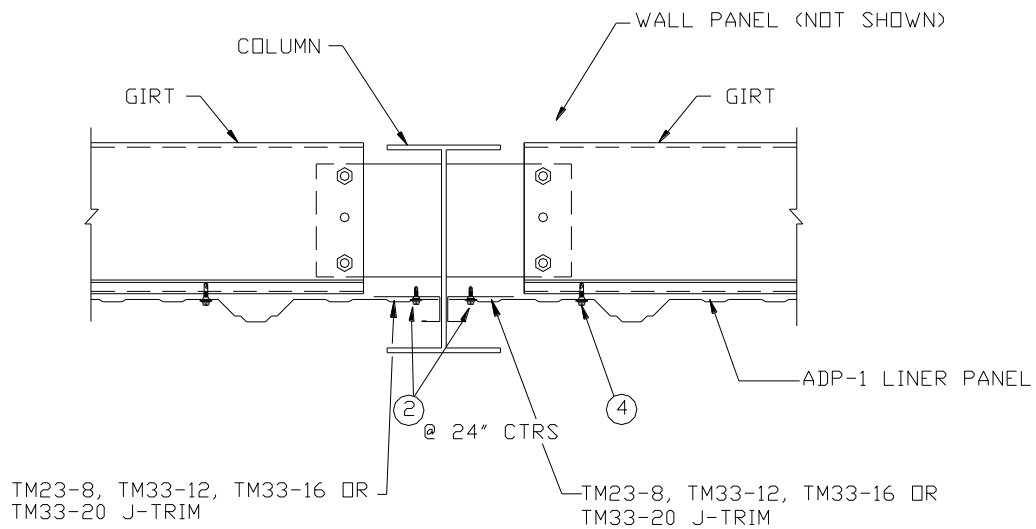

## WELDED COLUMN W/DEPTH GREATER THAN GIRTS DEPTH



# LINER AT CORNER – FLUSH SIDEWALL/ENDWALL GIRTS

## 1 INCH GIRT PROJECTION

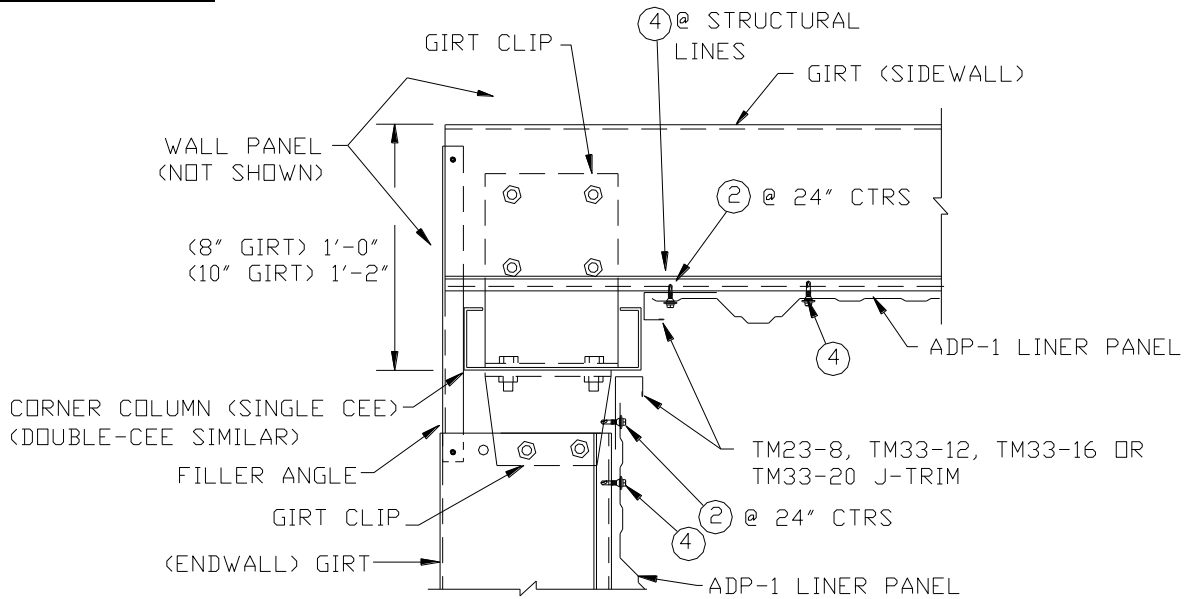

## CORNER COLUMN (SINGLE-CEE) (DOUBLE-CEE CORNER COLUMN SIMILAR)

- FLUSH SIDEWALL GIRT
- FLUSH ENDWALL GIRT

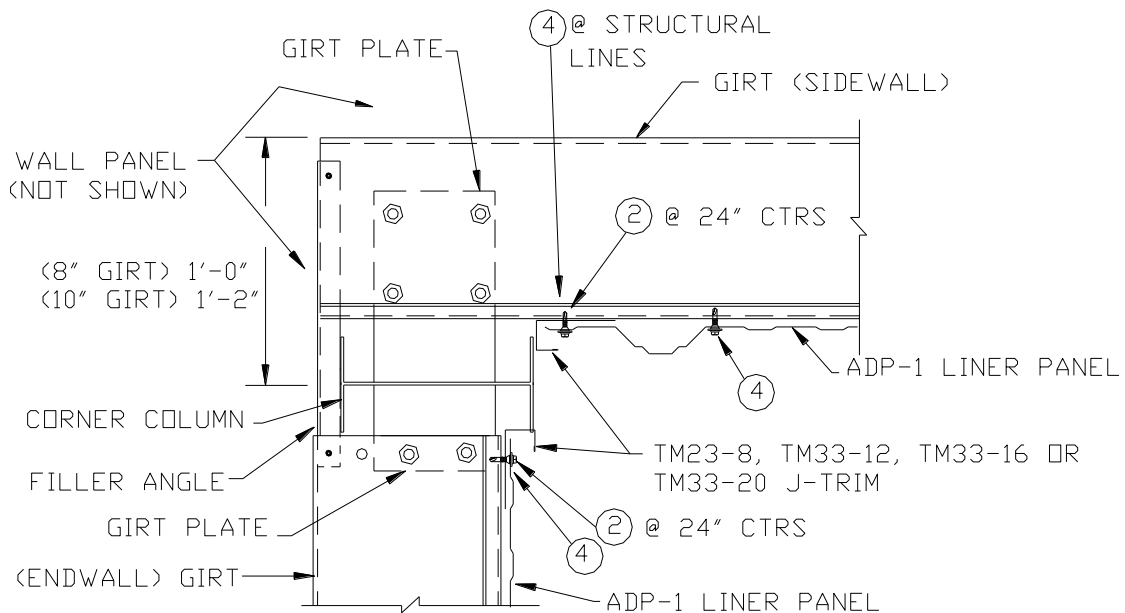

## CORNER COLUMN (WELDED)

- FLUSH SIDEWALL GIRT
- FLUSH ENDWALL GIRT

# LINER AT CORNER – FLUSH SIDEWALL/ENDWALL GIRTS

0 INCH GIRT PROJECTION

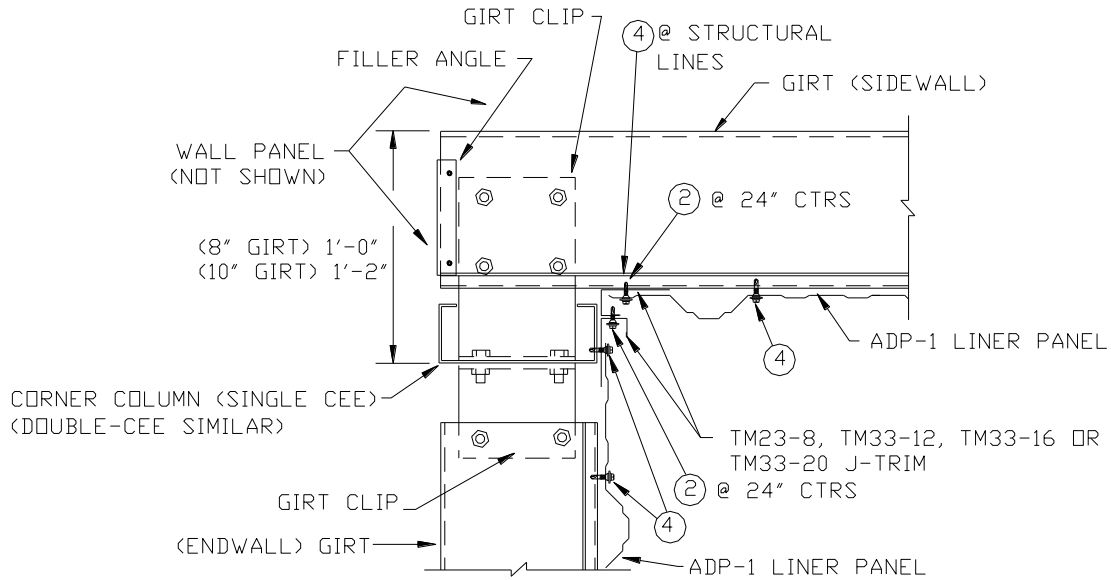

## CORNER COLUMN (SINGLE-CEE) (DOUBLE-CEE CORNER COLUMN SIMILAR)

- FLUSH SIDEWALL GIRT
- FLUSH ENDWALL GIRT

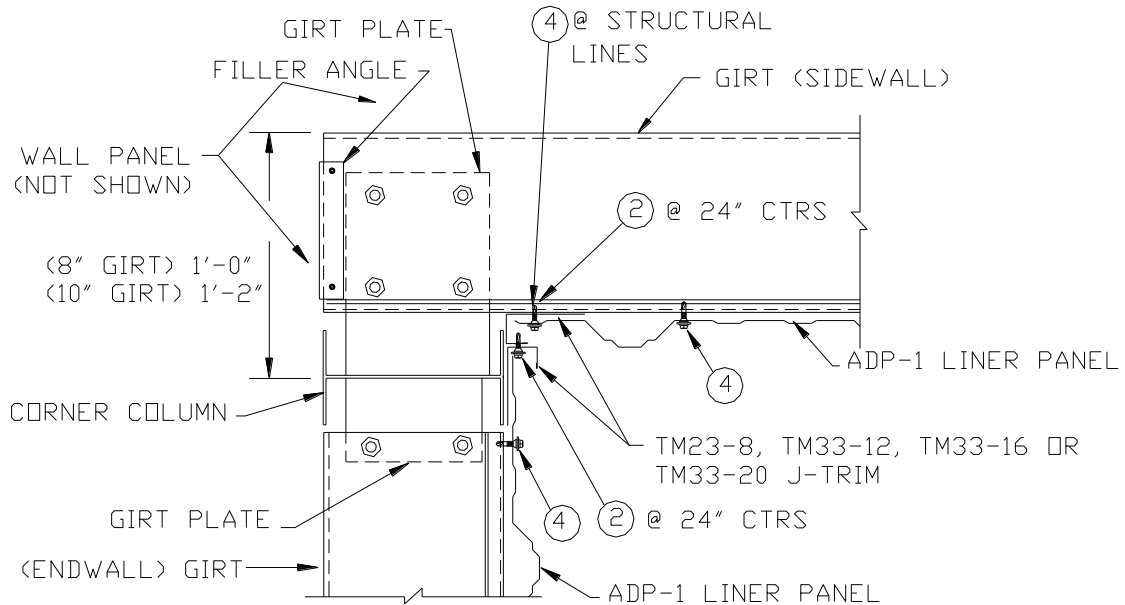

## CORNER COLUMN (WELDED)

- FLUSH SIDEWALL GIRT
- FLUSH ENDWALL GIRT

# LINER AT CORNER – FLUSH SIDEWALL/ENDWALL GIRTS

0 INCH GIRT PROJECTION (1 INCH GIRT PROJECTION IS SIMILAR)

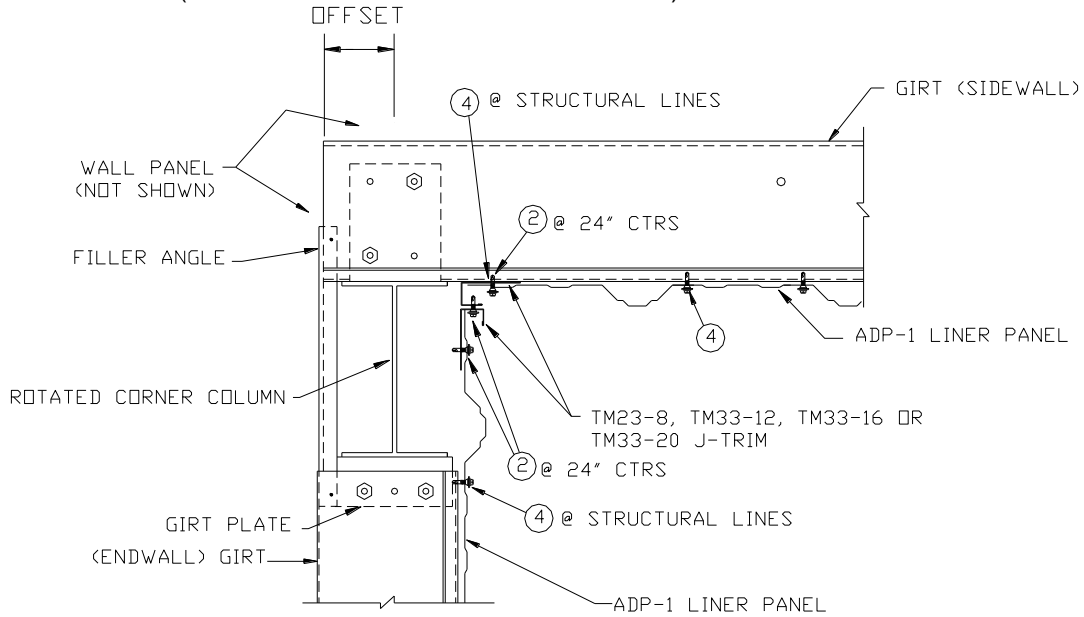

## ROTATED CORNER COLUMN W/4" OR 5" OFFSET

- FLUSH SIDEWALL GIRT
- FLUSH ENDWALL GIRT

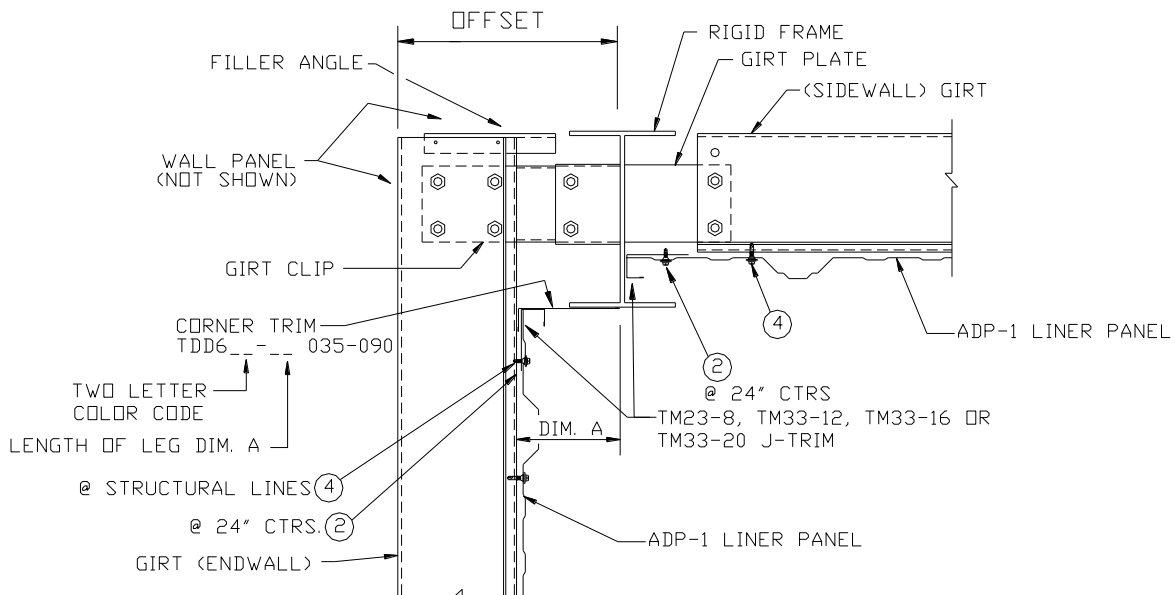

## RIGID FRAME AT ENDWALL W/1'-4" OR 1'-5" OFFSET

- FLUSH SIDEWALL GIRT
- FLUSH ENDWALL GIRT

# LINER AT CEILING

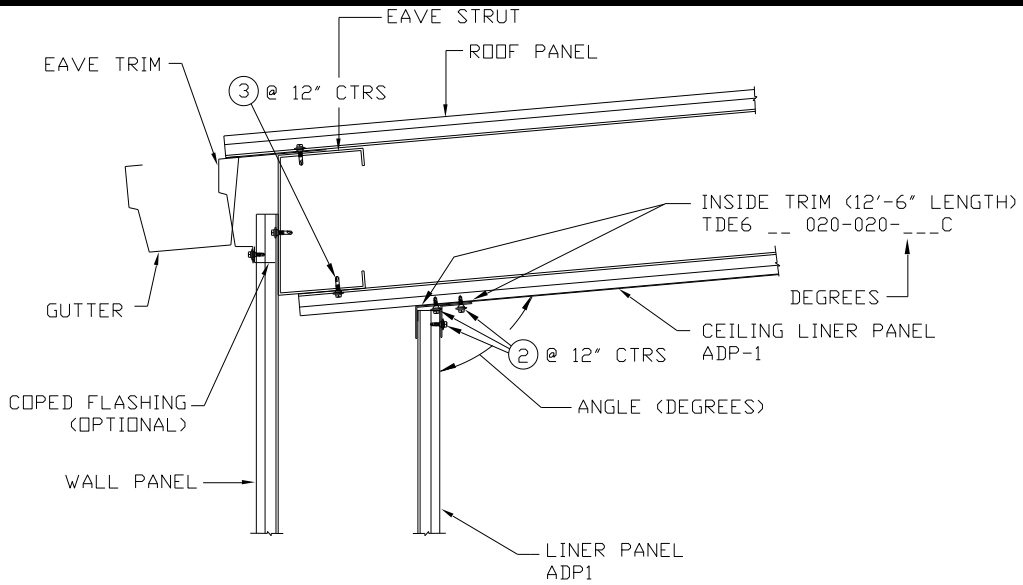

## AT EAVE

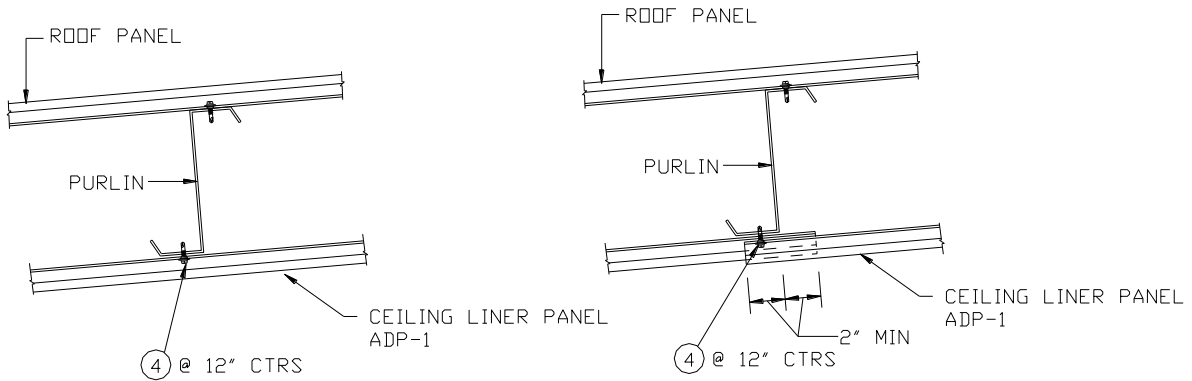

## LINER TO PURLIN

## LAP OF LINER AT PURLIN

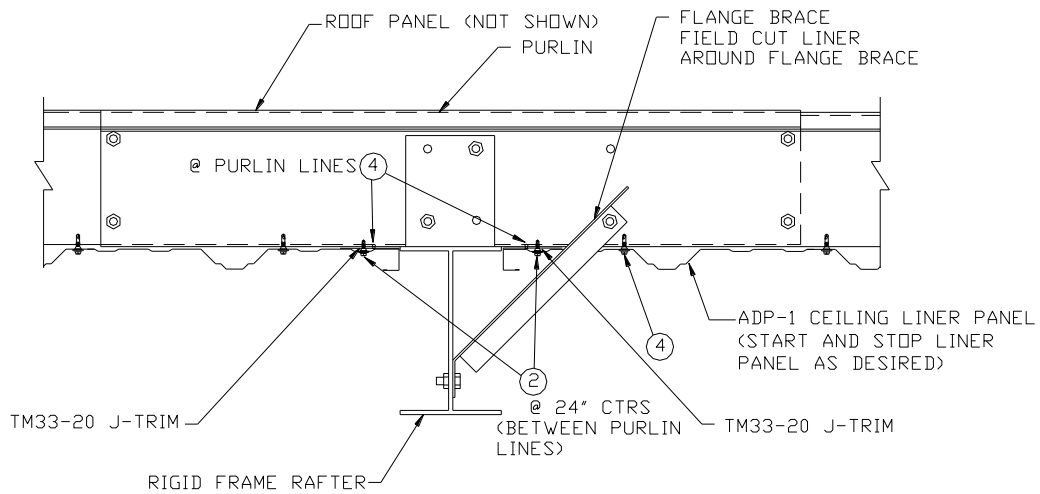

## LINER AT RAFTER

# LINER AT CEILING

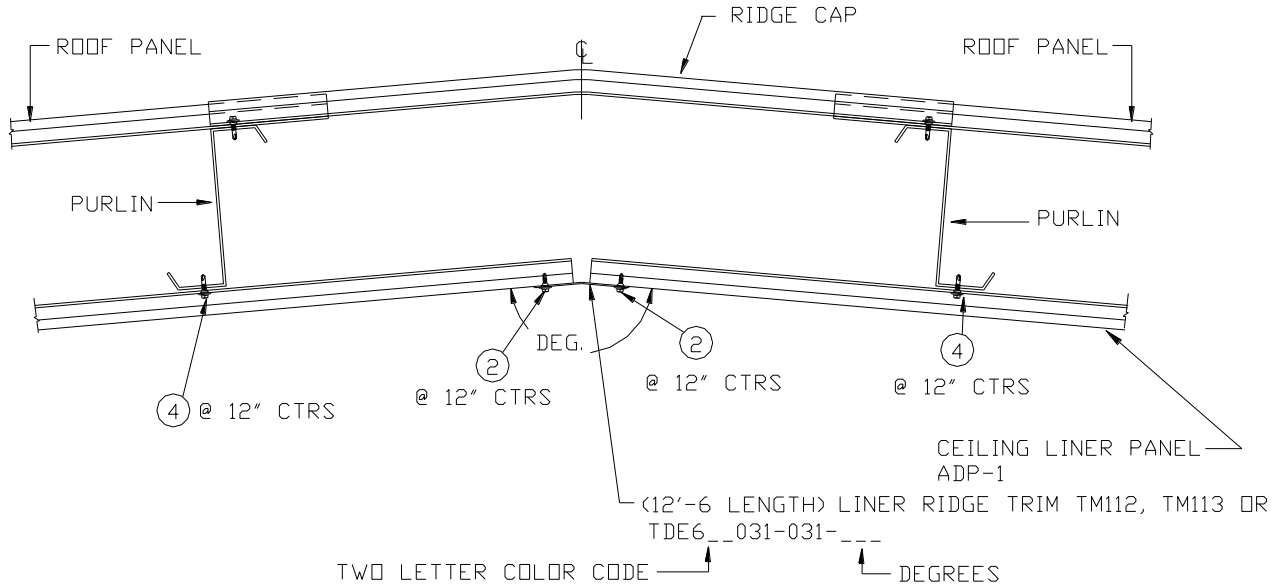

## LINER AT RIDGE

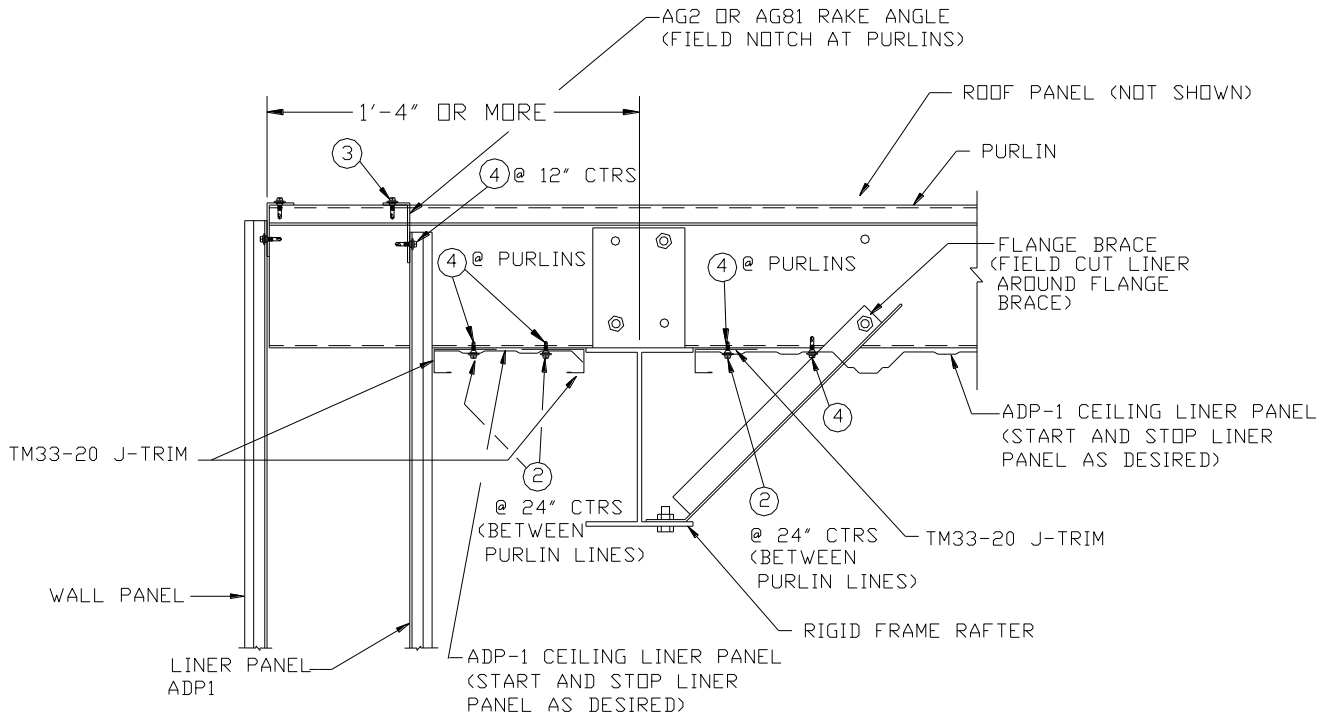

## LINER AT RAKE - RAFTER OFFSET OF 1'-4" OR MORE

# LINER AT CEILING

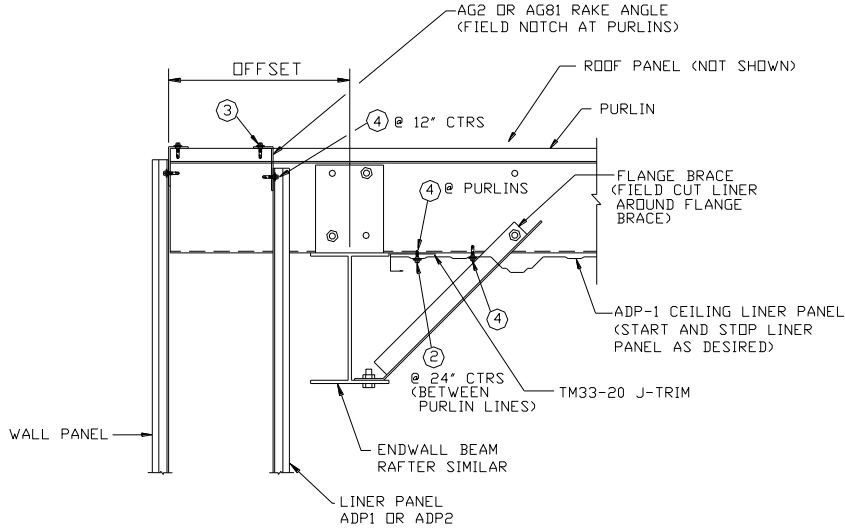

LINER AT RAKE - RAFTER W\6" MAX. FLANGE WIDTH - OFFSET OF 1'-0" OR 1'-2"

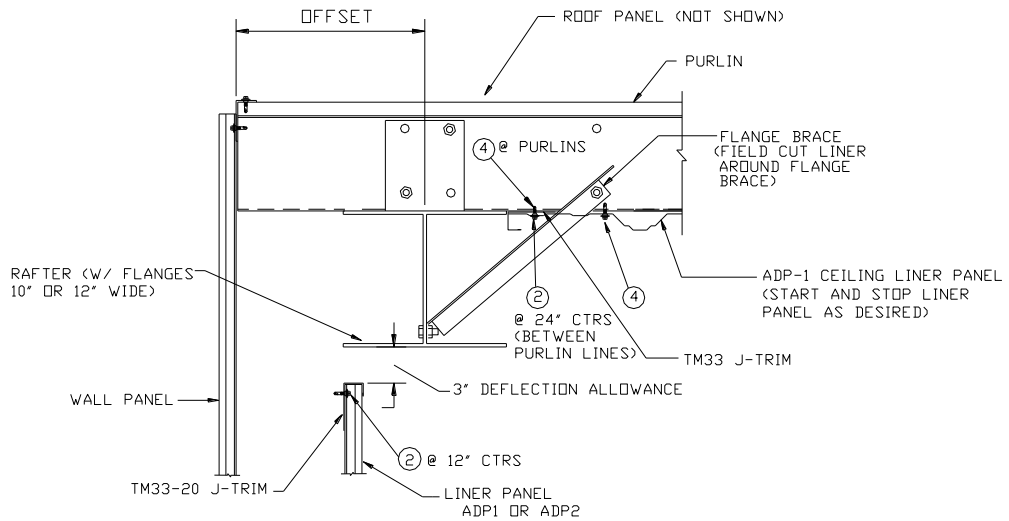

LINER AT RAKE - RAFTER W/8" FLANGE WIDTH - OFFSET OF 1'-0" OR 1'-2"

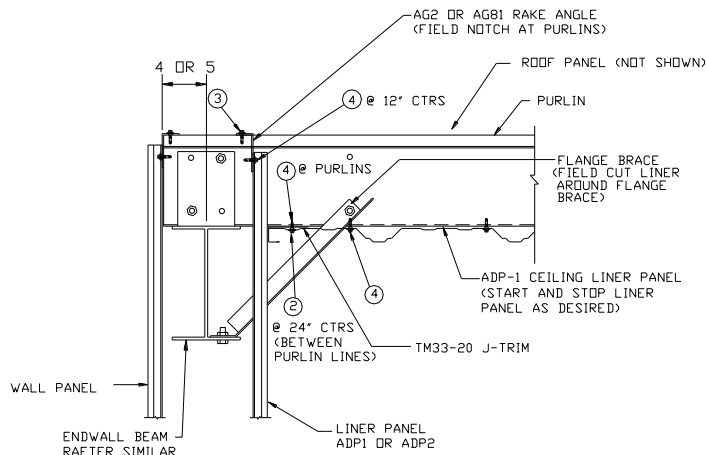

LINER AT RAKE - RAFTER OFFSET OF 4" OR 5"

# LINER AT SELF-FRAMING WINDOW

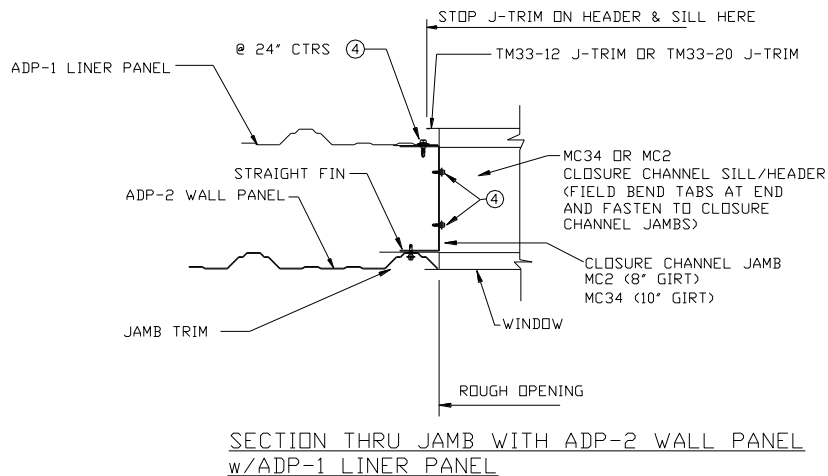
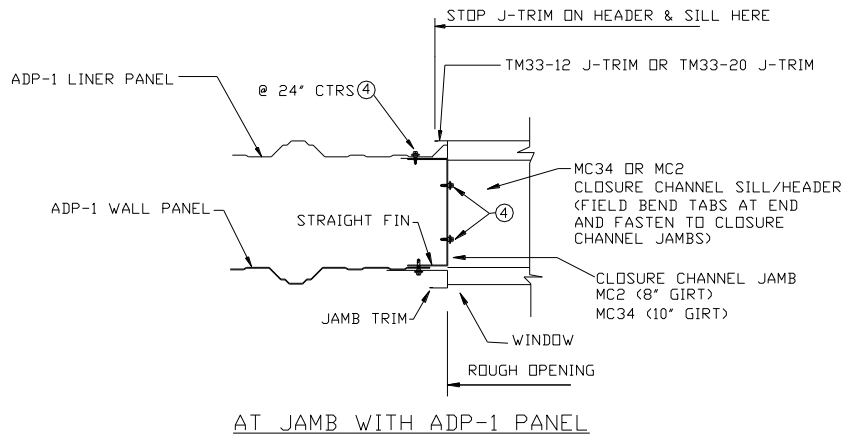
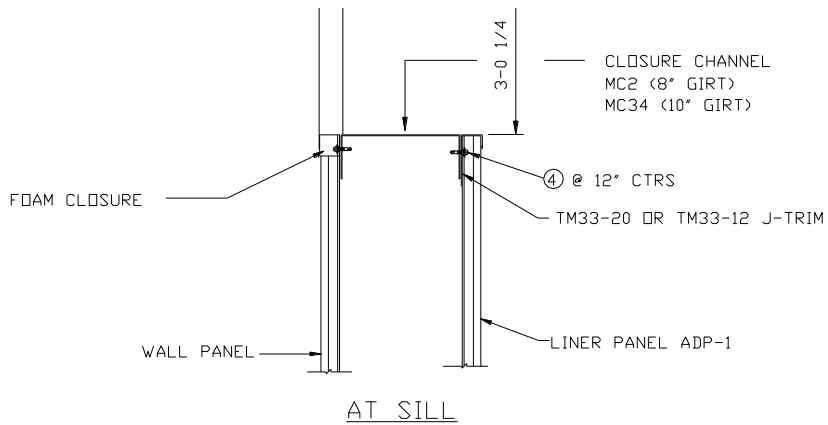
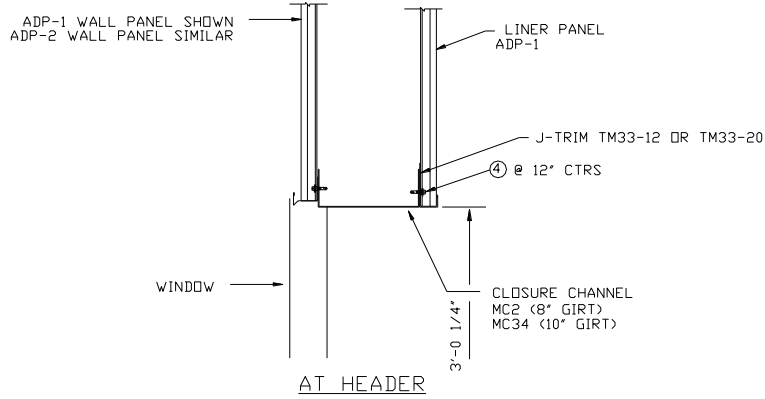

# LINER AT PREASSEMBLED WINDOW

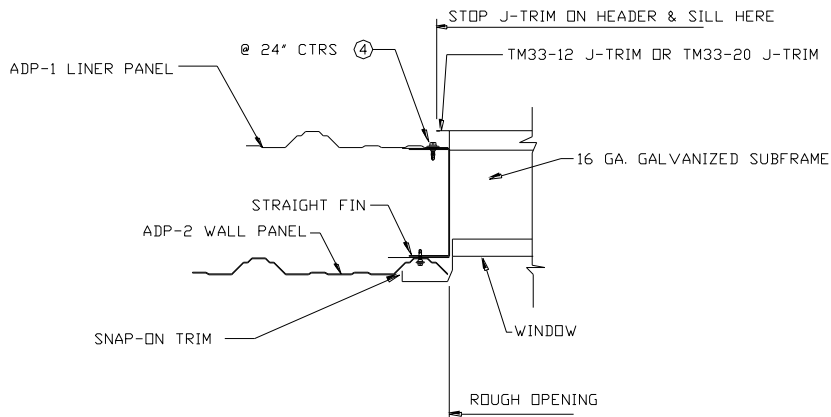
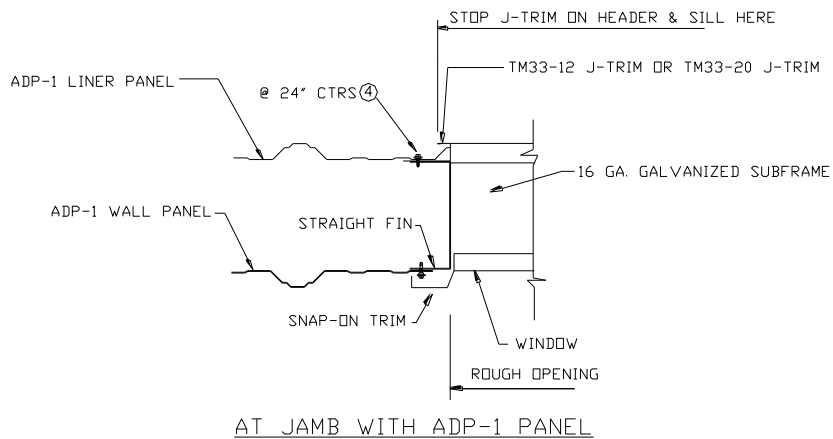
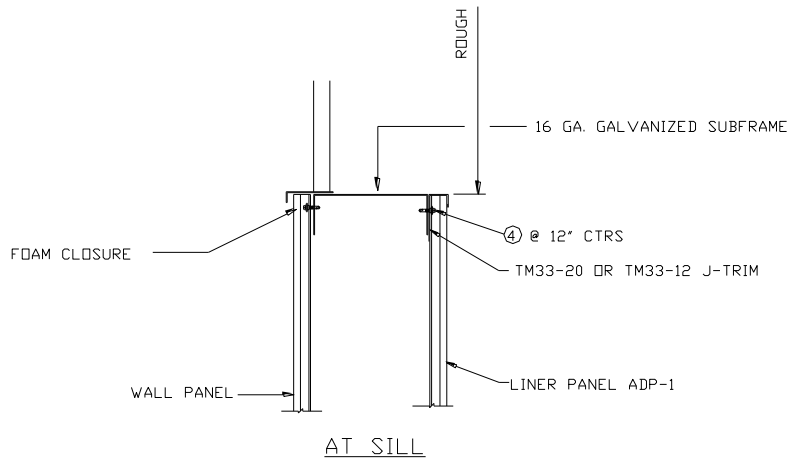
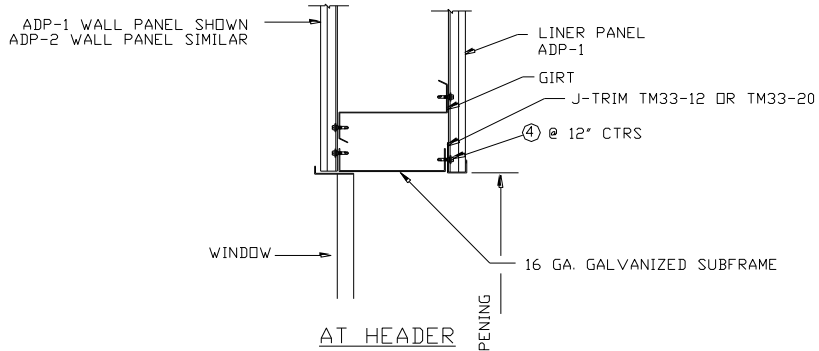

SECTION THRU JAMB WITH ADP-2 WALL PANEL  
w/ADP-1 LINER PANEL



# LINER AT KNOCK-DOWN DOOR

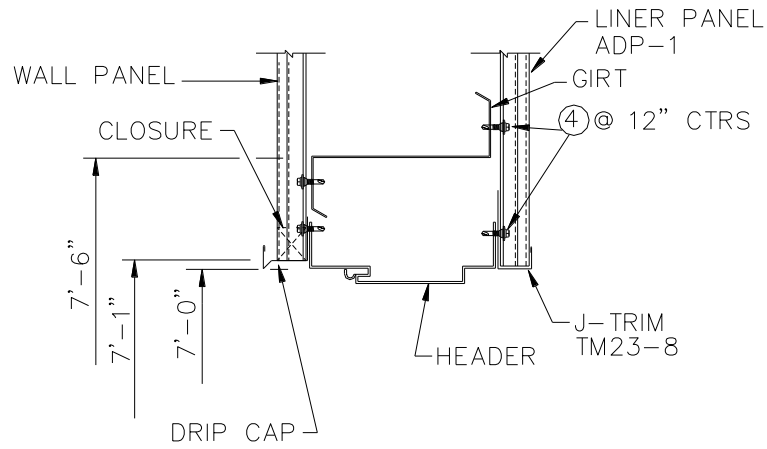

AT HEADER

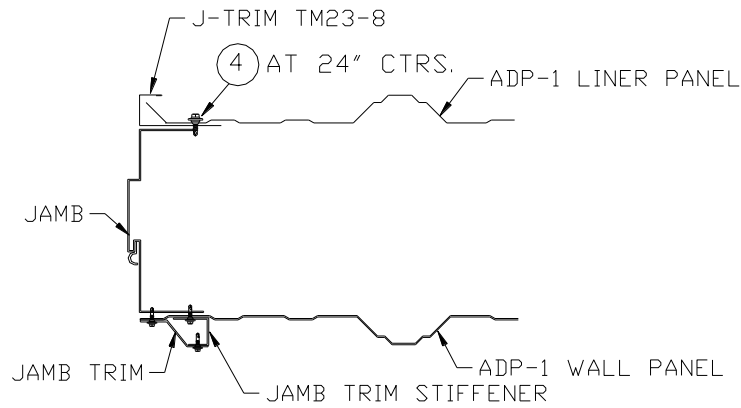

AT JAMB WITH ADP-1 WALL PANEL

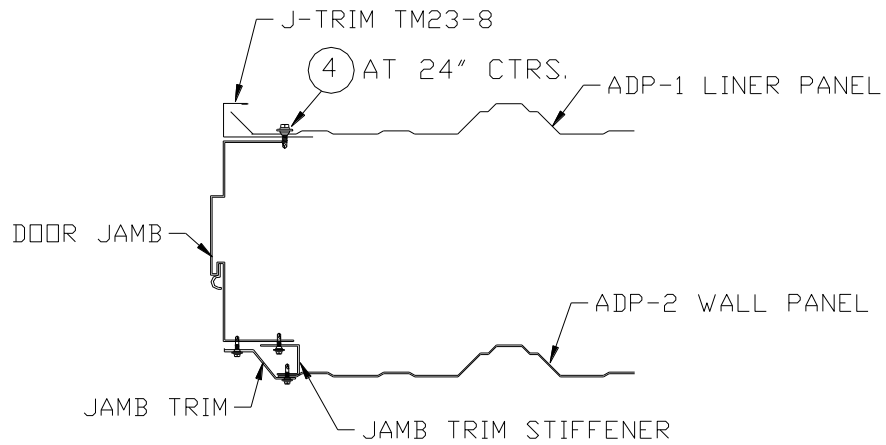

AT JAMB WITH ADP-2 WALL PANEL

# LINER AT PREASSEMBLED DOOR

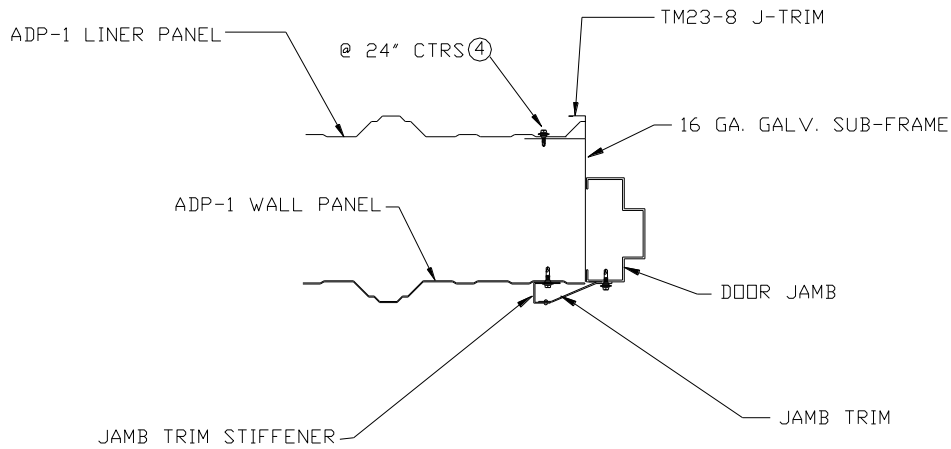
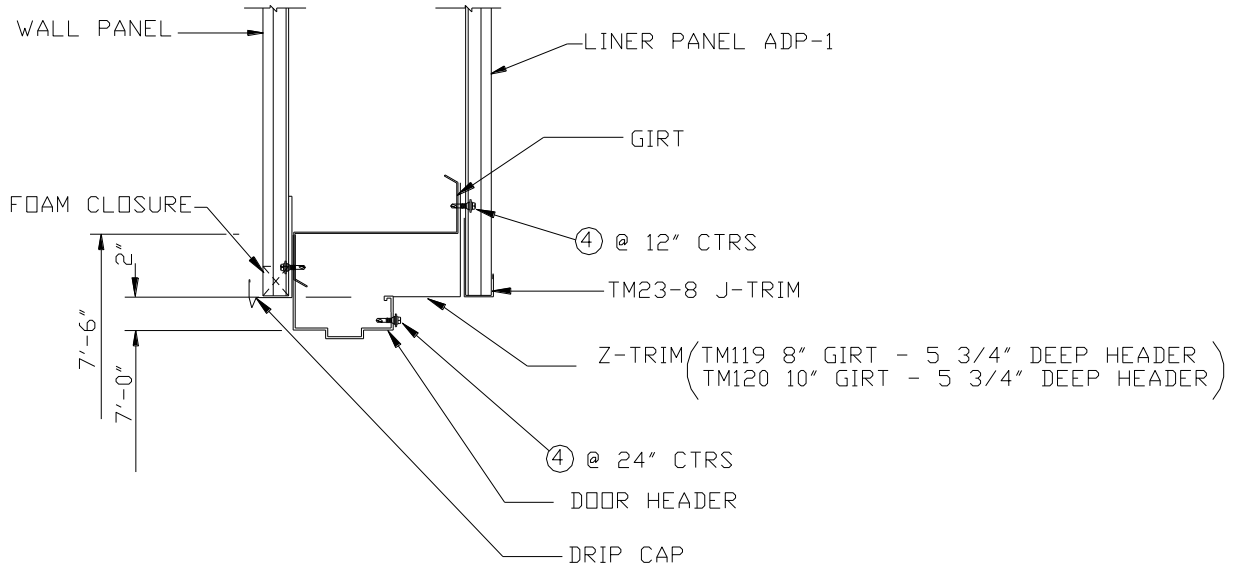

AT JAMB WITH ADP-1 PANEL

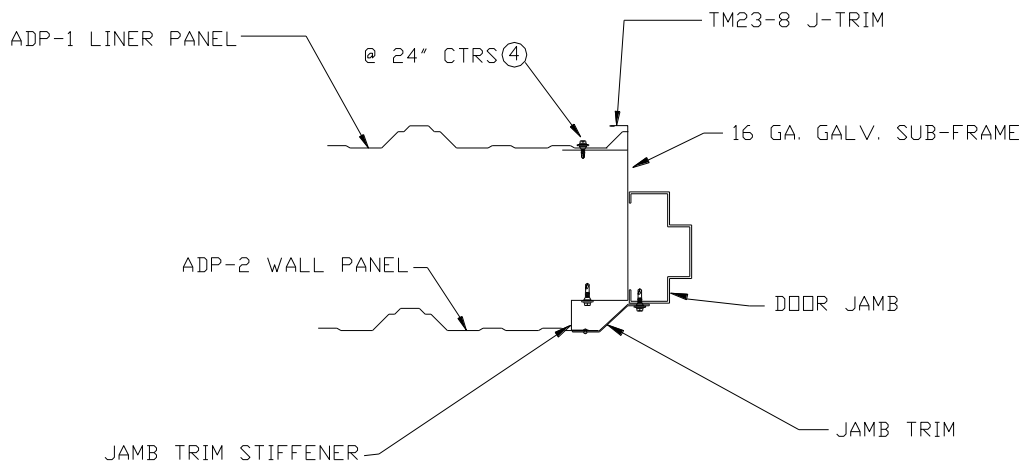

AT JAMB WITH ADP-2 WALL PANEL

# LINER AT WALK DOOR ROUGH FRAME

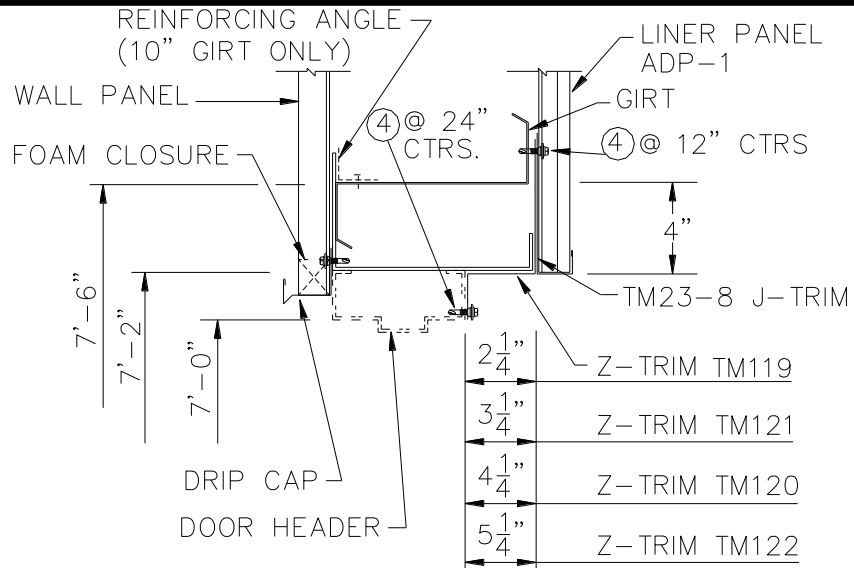

## AT HEADER

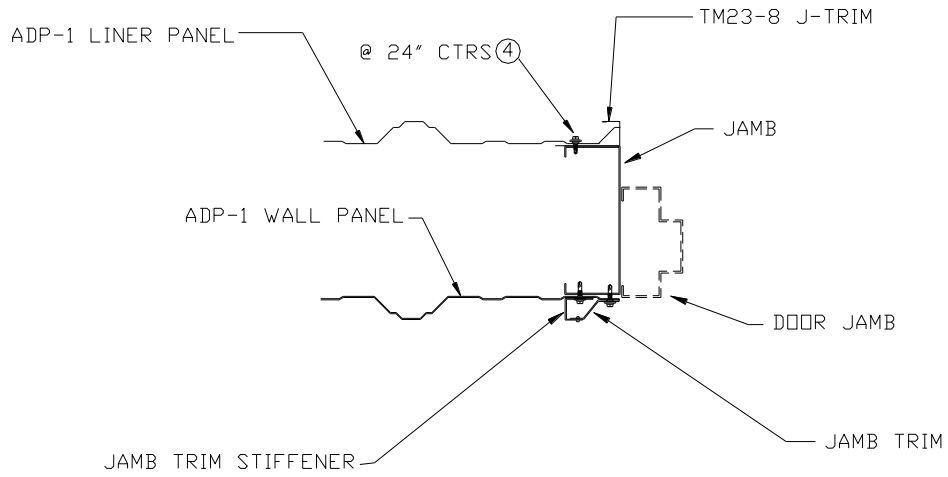

## AT JAMB WITH ADP-1 WALL PANEL

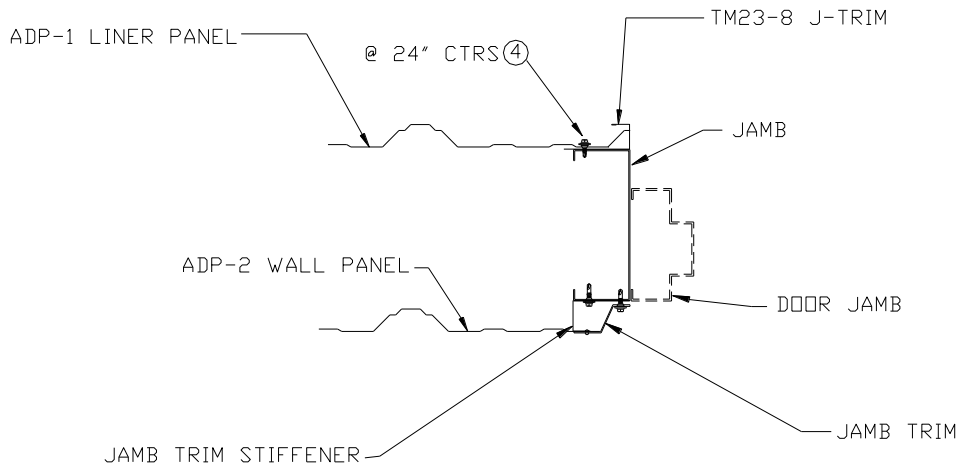

## AT JAMB WITH ADP-2 WALL PANEL

# LINER AT FRAMED OPENING

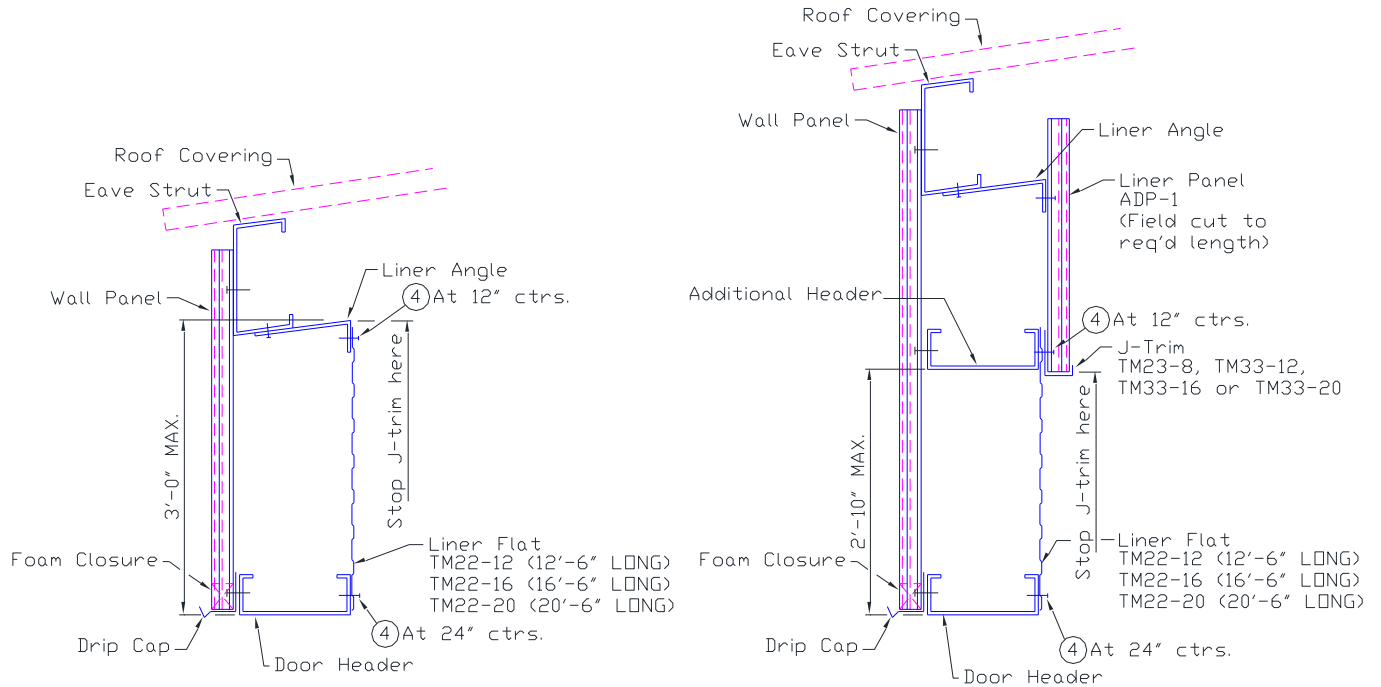

## HEADERS NEAR EAVE STRUTS

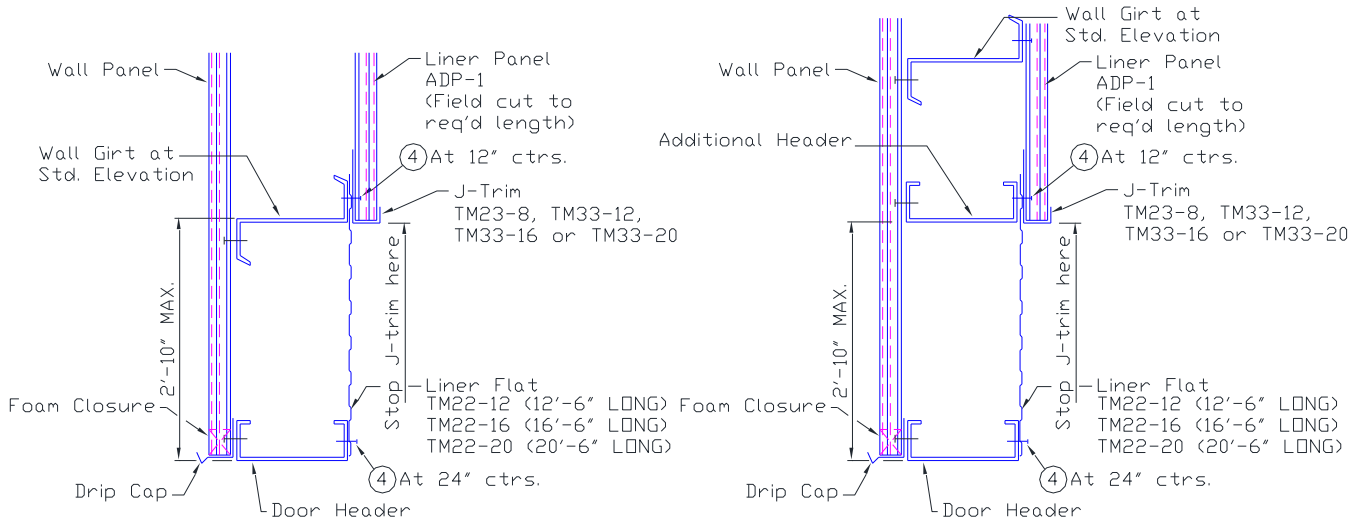

## HEADERS BELOW SIDEWALL / ENDWALL GIRTS AT STANDARD ELEVATIONS

# LINER AT FRAMED OPENING

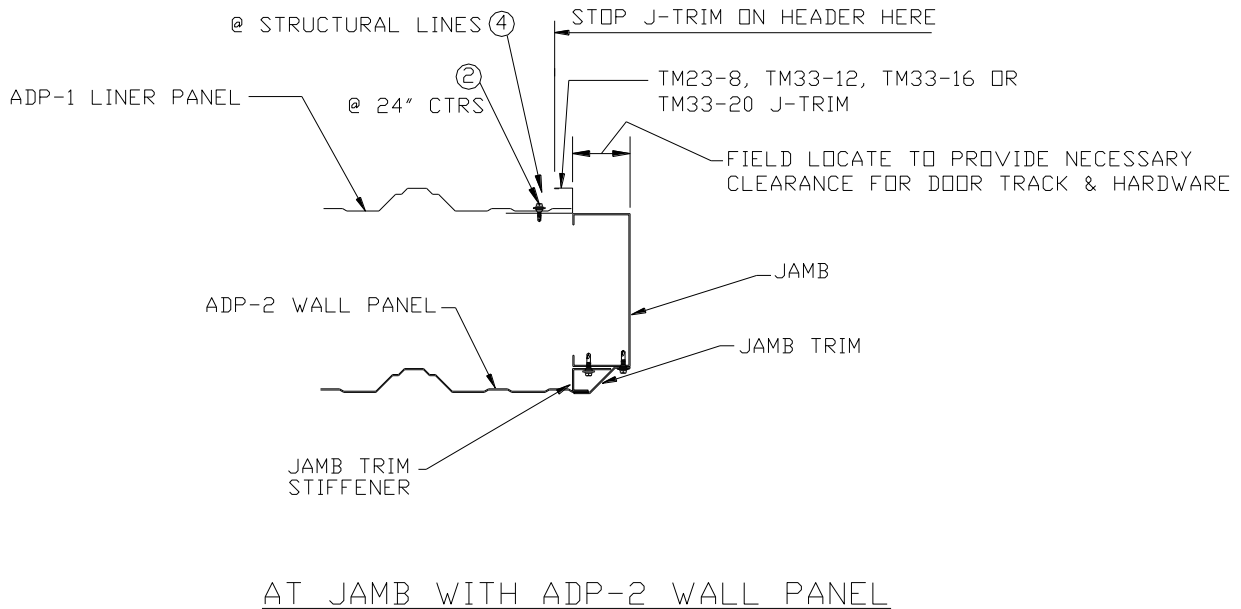
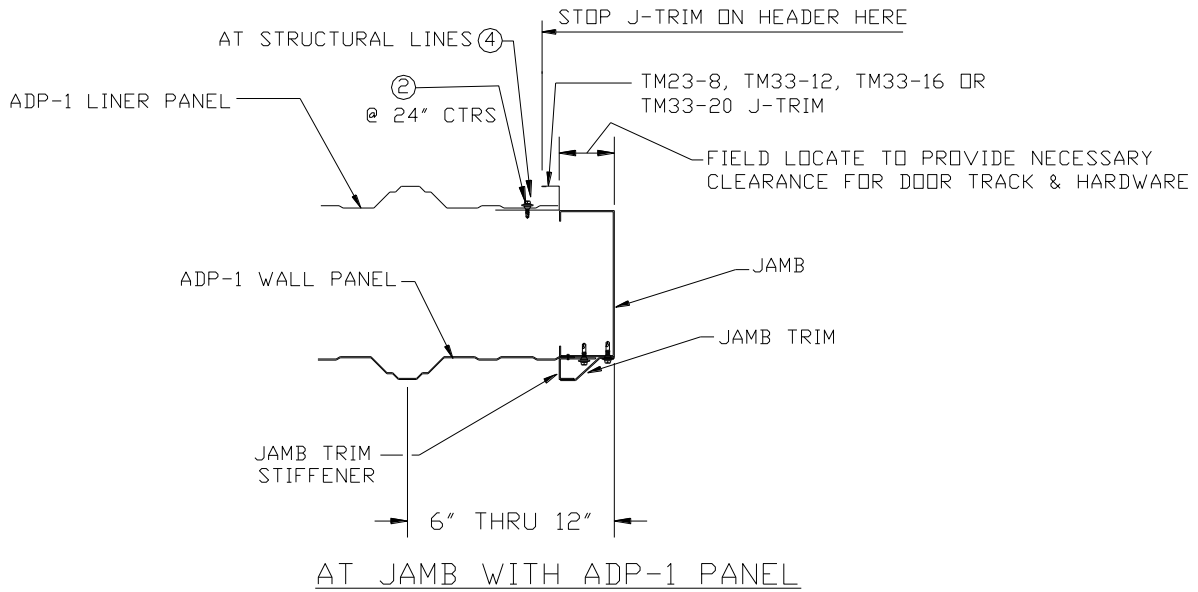

# LINER AT FRAMED OPENING WITH SILL

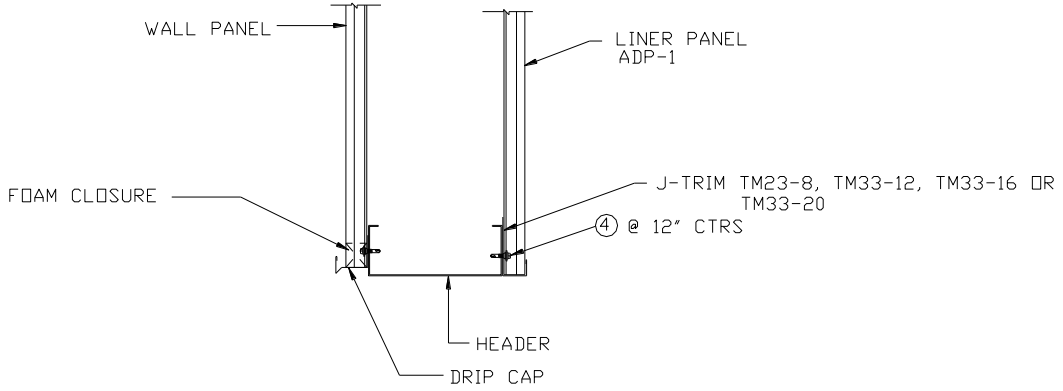

AT HEADER

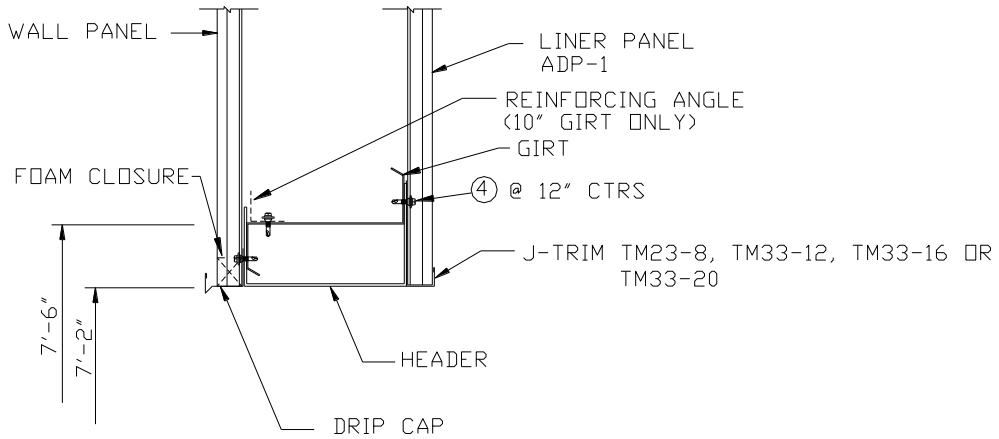

AT HEADER/GIRT

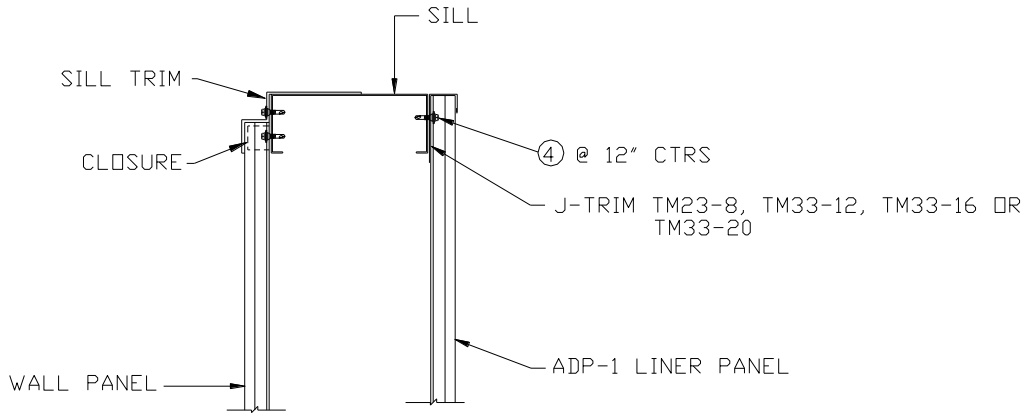

AT SILL

# LINER AT FRAMED OPENING WITH SILL

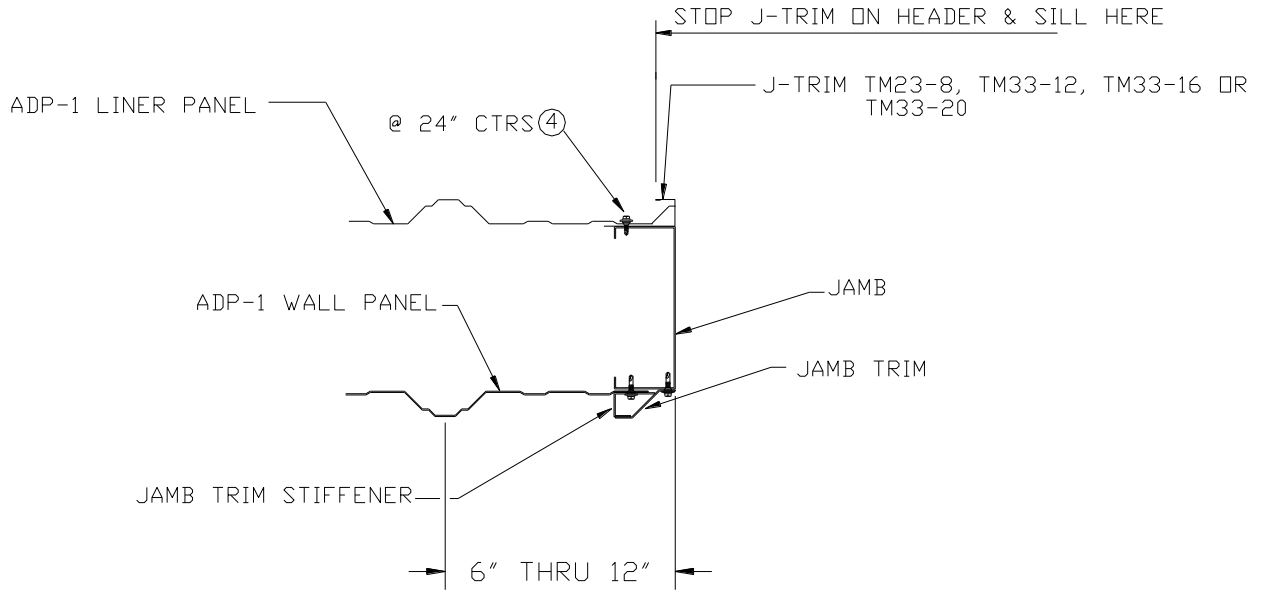

## AT JAMB WITH ADP-1 WALL PANEL

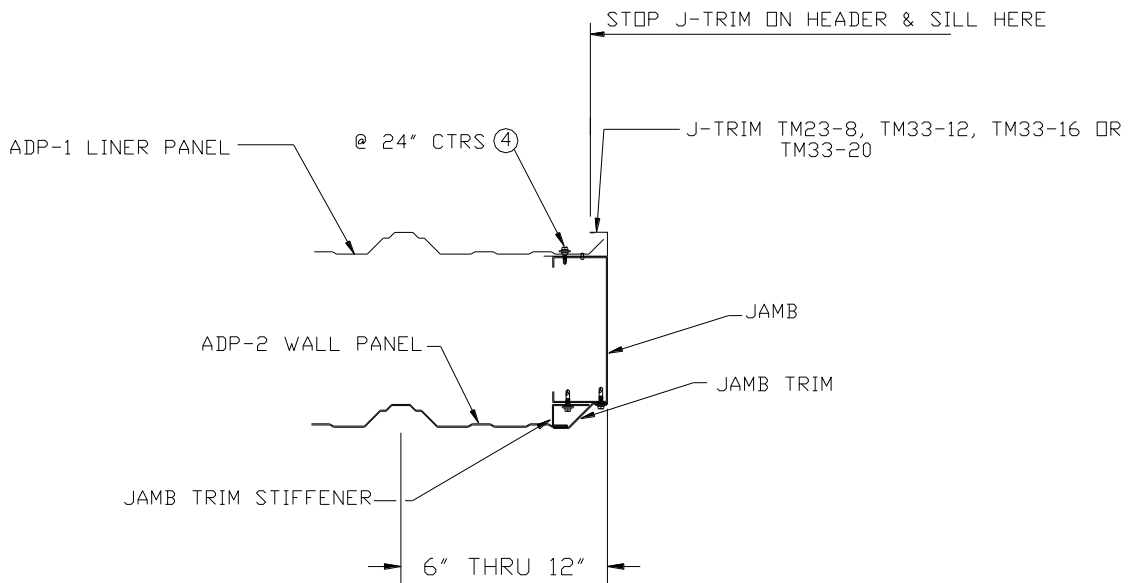

## AT JAMB WITH ADP-2 WALL PANEL