



ZL-16™ Standing Seam Roof



Good Iron. GREAT Experience!™

Serious Performance Through Superior Design

ZL-16™ Architectural Roof System

Reliable

The technology of the patented ZL-16™ vertical leg standing seam roof system offers considerable benefits to the roof designer, roof installer, contractor and building owner.

Weather Resistant

You can be assured with ZL-16™ technology, the sealant is protected from severe seam stresses during high wind uplift because of its location within the seam.

Cost-Efficient Installation

Unlike other systems on the market, the ZL-16™ roof system does not require seaming as each individual panel is installed. This is because the panel seam is partially formed automatically as the panels are placed, allowing the seaming to be accomplished after the entire roof has been installed. The result – a roof that is installed quickly, efficiently and without costly wear and tear caused by excess traffic on the unfinished roof.

Easy to Seam

With the ZL-16™ roof system, even operators with limited experience can accomplish a good seam. The ZL-16™ seam is larger by design which allows the seamer to stay locked in until the seaming process is completed.

Bottom-Line Result

In almost every case, your ZL-16™ roof system is accomplished with one consistent purlin spacing, one panel size, and one clip throughout the entire roof.

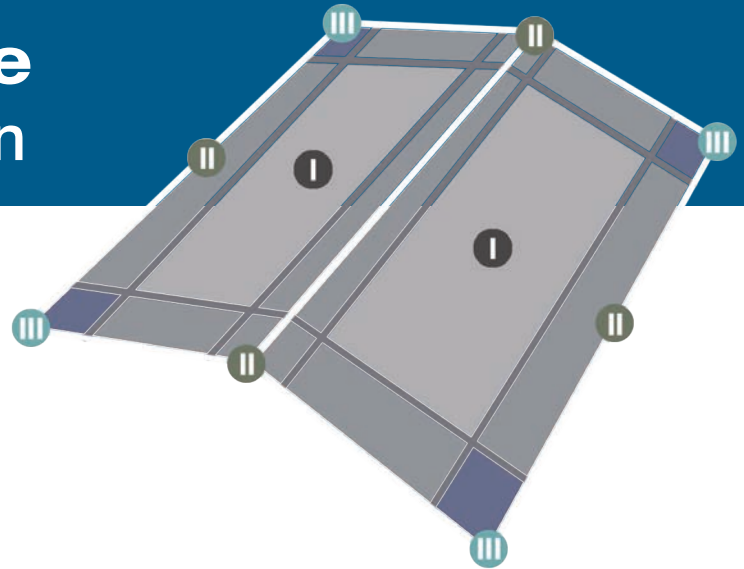

Standard industry wind tunnel tests on various roof configurations have shown that the wind loading on a roof is divided into three zones:

Zone I: Lowest Load

- Main field of the roof
- About 80% of total roof surface

Zone II: Intermediate Load

- Along the edges of the roof
- About 15% of total roof surface

Zone III: Highest Load

- At each corner of the roof
- About 5% of total roof surface

The Behlen ZL-16™ Roof System accommodates all three roof zones simply and efficiently by executing one of two seaming shapes. Each shape is formed in the field after the roof panels have been installed. Precise roof wind loading requirements are met with our roof system by matching seaming profile to loading.

It all begins with a Revolutionary Seam

Triple-Lock™

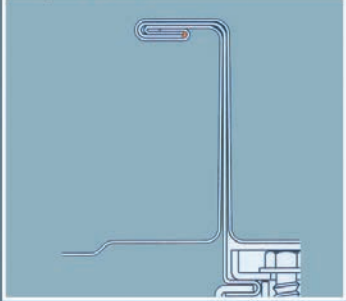

Quadri-Lock™

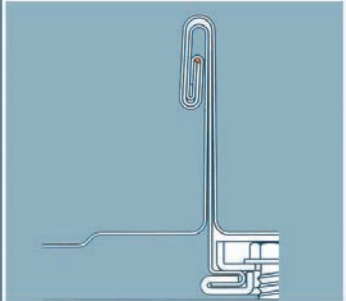

Mechanical Seamer

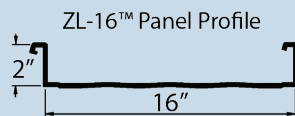
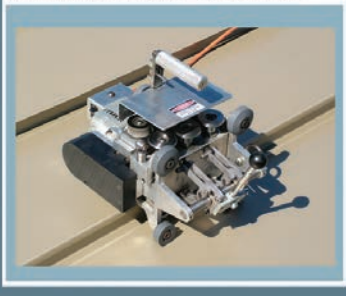

The Triple-Lock™ seam is accomplished by seaming the entire seam with an electric seamer and will provide an allowable wind uplift rating of 56.6 psf.* The Quadri-Lock™ seam usually is only required in extremely high wind areas such as coastal regions when required. This seam is accomplished by seaming special roof zones with an electric seamer and will provide an allowable wind uplift rating of 78.8 psf.*

A 24 gauge ZL-16™ roof system with a Quadri-Lock™ seam can provide higher uplift resistance than many other 22 gauge roof systems.

**When seamed with 24 gauge panels with 5'0" purlin spacings. All of the above seams' load allowances are calculated using ASTM E 1592 test results.*

The entire roof can be seamed with an electric seamer if desired.

A better connection makes for a better roof

Clips



Fixed Clip

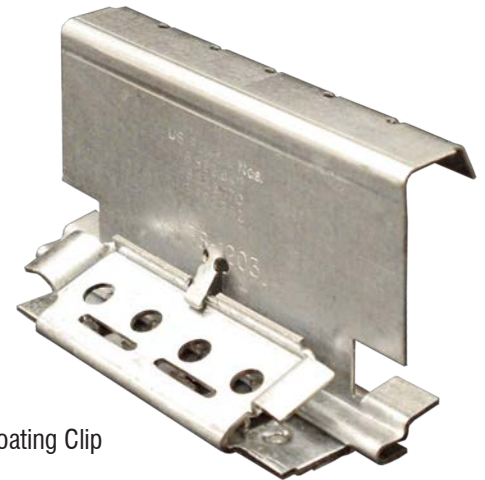

Floating Clip

These patented panel clips provide even greater air and water resistance because they don't interfere with the sidelap seam sealant.

- Full 3½" of roof movement allowed
- Positive acting centering tab
- All clips are formed from G-90 galvanized steel
- Patented floating clip base

Easy, Reliable & Cost Efficient.

Tests and Certifications

The ZL-16™ Vertical Leg Standing Seam roof system has been tested and certified by independent testing agencies and laboratories, achieving the loads and listings shown below:

Underwriters Laboratories, Inc. UL-580 Uplift Test
 Corps of Engineers CEGS 07416 Uplift Test
 ASTM E 1592 Uplift Test
 ASTM E 1680 Air Leakage Test
 ASTM E 1646 Water Penetration Test

Underwriters Laboratories Inc. UL-580 Uplift Test Results

Construction No. 506, 506A and 506B - ZL-16™ roof with Triple-Lock™ or Quadri-Lock™ Seam

UL Listing	Panel Width	Panel Gauge	Seam Type	Purlin Gauge	Purlin Spacing
UL-90	16"	24 ga.	All Seam Types	16 ga.	5' 0"

ASTM E 1592 Uplift Test Results

ZL-16™ roof with Triple-Lock™ Seam

Purlin Spacing	Panel Width	Panel Gauge	Uplift Design Capacity
2' 0"	16"	24 ga.	136.4 psf
5' 0"	16"	24 ga.	56.6 psf

ASTM E 1592 Uplift Test Results

ZL-16™ roof with Quadri-Lock™ Seam

Purlin Spacing	Panel Width	Panel Gauge	Uplift Design Capacity
2' 0"	16"	24 ga.	191.3 psf
5' 0"	16"	24 ga.	78.8 psf

ASTM E 1680 Air Leakage Test all seams 16" wide panels - .0005 CFM/sq.ft

ASTM E 1646 Water Penetration Test all seams 16" wide panels - None at 12 psf

ZL-16™ roof system and its components are covered by US Patent numbers 5,692,352-5,737,894-6,301,853 B1 and other patents pending.



AD-20635 03-22-24

