

ADP-1 WALL PANEL

ERECTION GUIDE

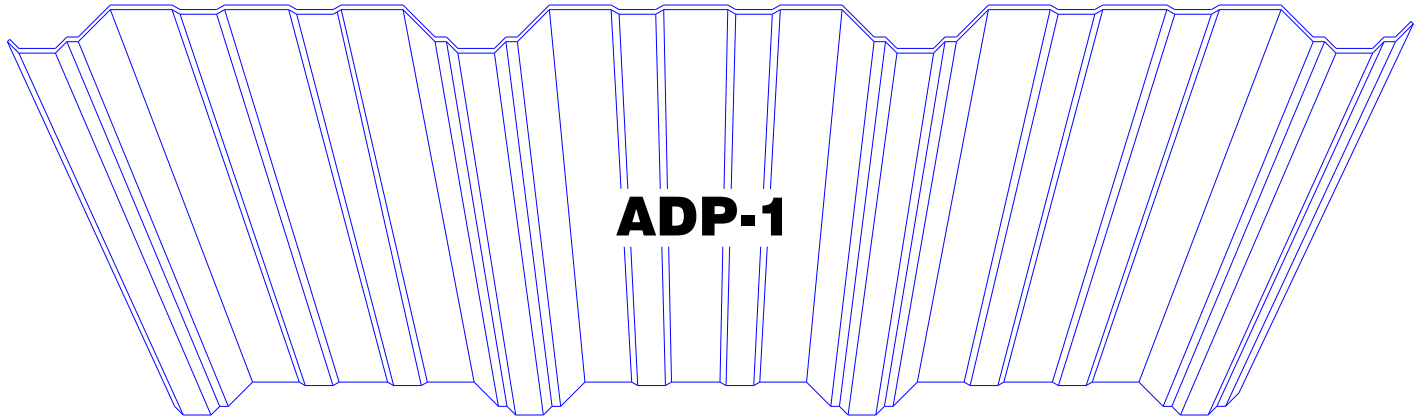

BBEHLLEN
4025 E. 23rd St. • Box 569
Columbus, Nebraska 68601



NOTE: See back side of cover for latest changes to this manual.

TABLE of CONTENTS

PAGE

1 GENERAL INFORMATION 2

1.A INTRODUCTION 2

1.B SAFETY AND OSHA REGULATIONS 2

1.C QUALITY 3

1.D ERECTION DRAWINGS 3

1.E EQUIPMENT AND TOOLS 3

1.F RECEIVING SHIPMENT 4

1.G UNLOADING MATERIALS 5

1.H STORAGE 6

1.I LAYOUT OF COMPONENTS 7

2 ERECTION SEQUENCE - FRAMING 8

2.A ANCHOR BOLT AND FOUNDATION CHECK 8

2.B ERECTION SEQUENCE 8

2.C TIGHTENING A325 BOLTS 13

2.D GENERAL FRAMING 14

3 TRIM COMPONENTS 14

3.A TRIM IDENTIFICATION 14

3.B HANDLING LONG TRIM 16

3.C PROTECTIVE FILM REMOVAL 16

3.D TOUCH-UP PAINT 17

4 FASTENERS 18

4.A IDENTIFICATION AND USAGE 18

4.B FASTENER PATTERNS 19

4.C SEATING OF FASTENERS 19

4.D TROUBLE SHOOTING GUIDE 20

4.E ATLAS RECOMMENDATIONS 22

5 COVERING AND TRIM 23

5.A ALIGNING GIRTS 23

5.B BLANKET INSULATION 23

5.C TRIM AT BASE OF PANEL 27

5.D CLOSURES AT BASE AND TOP OF PANEL 28

5.E WALL PANEL INSTALLATION 28

5.F INSTALLING OUTSIDE CORNER TRIM 31

5.G INSTALLING INSIDE CORNER TRIM 32

5.H TRIM AT TOP OF WALL PANEL 33

6 ACCESSORIES 34

6.A FRAMED OPENINGS 34

6.B FRAMED OPENINGS WITH SILL 36

6.C PREASSEMBLED WALK DOOR 38

6.D WALK DOOR ROUGH FRAME (BELOW 7'-6" GIRT ELEV.) 40

6.E PREASSEMBLED WINDOW 43

6.F ROUGH FRAME WITH SILL (BELOW 7'-6" GIRT ELEV.) 44

6.G TRANSLUCENT WALL LIGHT 48

1 GENERAL INFORMATION

**NOTE: INFORMATION CONTAINED IN THIS BOOK
WILL NOT SUPERSEDE INFORMATION
SHOWN ON ERECTION PLANS SUPPLIED
WITH THE BUILDING.**

1.A INTRODUCTION

The erection information presented herein is provided as a supplement to the erection drawings prepared for your specific job. The information, illustrations and procedures in this guide are typical for most Behlen buildings. Variations may occur because of special building requirements. Always refer to the erection drawings supplied with each job which will govern specific part and assembly arrangements and applicable installation details.

By studying the erection drawings and this guide before arrival of the steel at the job site, these cost critical requirements can be predetermined.

1. Size and scheduling of the work crew.
2. Type, size and quantity of tools and hoisting equipment needed.
3. Proper scheduling of erection sequence.
4. Advance notations on erection drawings to call out items requiring field location or modification.
5. Identification and resolution of questions.

Because Behlen products are constantly being improved, the information contained herein is subject to change without notice.

1.B SAFETY AND OSHA REGULATIONS

Behlen Mfg. Co. strongly recommends that safe working conditions and accident prevention practices be the top priority on any job site.

Contractors should ensure compliance with all relevant local, state and federal safety and health standards, including, but not limited to 29 CFR 1926 Subpart R, Steel Erection Standards.

Make certain all employees know the safest and most productive way of erecting a building. Emergency telephone numbers, location of first aid stations and emergency procedures should be known to all employees.

Daily meetings highlighting safety procedures, the use of hard hats, rubber sole shoes for roof work, proper equipment for handling material and safety nets where possible are recommended erection practices.

OSHA REGULATIONS

The Occupational Safety and Health Act has promulgated many regulations applicable to the erection of this or any other building. These regulations, identified as Part 1926, Safety and Health Regulation for Construction, are available from any government bookstore.

Compliance with OSHA regulations should be recognized as a job site requirement. Failure to do so may result in substantial fines.

Identification of specific requirements for erection is beyond the scope of this documentation. The objective of the OSHA standards is to protect the worker from injury or illness. Past erection methods may not comply with current requirements.

Safe erection practices may be further defined and made mandatory by state or local ordinances. Maintenance of good housekeeping on the job site is recognized as being most important to both OSHA compliance and to successful job completion.

1.C QUALITY

The builder and/or erector is expected to be thoroughly familiar with the contents of this manual. If the erection crew is not experienced in the proper techniques in the erection of a BEHLEN frame building, technical field assistance is available. BEHLEN MFG. CO. must charge for this service. Contact our Customer Service Dept. for current rates. Deviations from the instructions outlined in the manual may void any and all warranties.

1.D ERECTION DRAWINGS

Erection drawings fall into two categories: (1) Plan drawings which cover general framing, and (2) detail drawings which contain specific part and assembly information.

1. Plan drawings will include the following:
 - A. Anchor Bolt Plan
 - B. Roof Framing
 - C. Wall Framing
 - D. Main Frame Cross Section
 - E. Endwall Panel
 - F. Sidewall Panel

Each plan drawing will include necessary dimensions and part numbers for proper positioning of parts during erection. Each page will be identified by a sheet number in the title block.

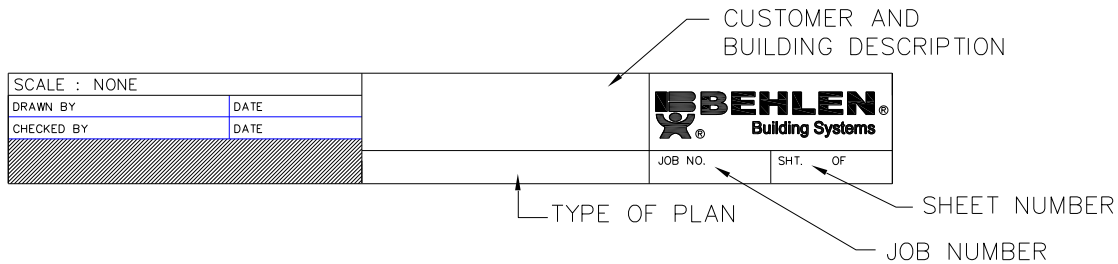

ILLUS. 1.1 TITLE BLOCK ON PLANS

2. Detail drawings may include the following:
 - A. Structural Framing Details
 - B. Covering and Trim Details
 - C. Accessories, such as: Overhangs, Facades, etc.

Each page will be identified by a sheet number in the title block. Details will not be referenced from one page to another but will be clearly identified in the title.

1.E EQUIPMENT AND TOOLS

Proper tools of suitable size increase the production and decrease the possibility of rework.

A spreader bar used with a forklift or crane is one piece of equipment that is essential in unloading sheeting. The spreader bar eliminates the possibility of buckling long sheets when they are being lifted from the bed of the truck. Unloading primary and secondary structural steel can also be facilitated by the use of a spreader bar. This technique is very simple and is recommended over the use of shakeout hooks. Be certain of lift and reach requirements for all crane work.

Self-drilling screws should be installed with a 1800 rpm (about 4 amp) screw gun.

SAFETY PRECAUTION
Use of heavy-duty, grounded electrical extension cords is recommended.

The following is a list of tools and equipment that should be available on any job site:

1. Crane, Forklift or Boom Truck
2. A well organized Tool Truck
3. Storage Shed
4. Screw Gun (1800 r.p.m.)
5. Electric Cords w/Multiple Outlets
6. Spreader Bar
7. Slings
8. Acetylene Torch
9. Scaffolding
10. Ladders
11. Transit
12. Sawzall with Blades
13. Drills and Bits
14. Sockets from 1/4" to 1"
15. Extensions for Sockets
16. Spud Wrenches
17. Open-End Wrenches
18. Vise Grips
19. Crescent Wrench
20. Electric Welder
21. Impact Wrench
22. Tie-offs (Steel Cable)
23. Nibblers
24. Drift Pins
25. Caulking Gun

1.F RECEIVING SHIPMENT

Dealer should check the materials received against the shipping document during unloading and make note of any shortages, damage on the shipping document before signing it as receiver of the shipments. Some items are received in bundles or boxes (such as trim and panels) and are signed for as such. If damage or shortages are noted on shipping document and verified, replacement parts will be shipped.

1.G UNLOADING MATERIALS

The careful unloading of building components is recommended. Hoist or lift structural members, crates and bundles from the truck. Trim which is lighter than structural members require more care. Trim should be handled with web belting or by hand.

SAFETY PRECAUTION:
Stay well in the clear of loads being moved by any lifting device.

It is the BUYER'S responsibility to supply equipment for the safe unloading of the material. Behlen Mfg. Co. is not liable for any damage of material or injury to personnel occurring during or after unloading. Below are suggested methods of lifting materials. Improper unloading and handling of bundles and crates may cause damage to material, equipment or injury to personnel.

STRUCTURAL FRAMING

- Columns, rafters, girts, purlins and other like components should be lifted with a forklift or crane utilized two wire rope (steel chokers 12' to 16' in length) positioned at the center of gravity.

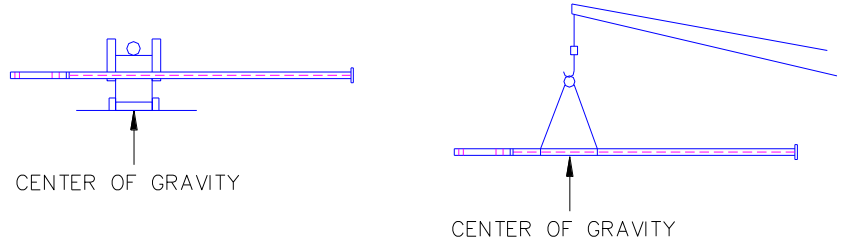

ILLUS. 1.2 LIFTING STRUCTURAL MEMBERS

PANEL BUNDLES

- Panel bundles up to 20' can be lifted with a forklift with a minimum of 32" between forks. The forks should be positioned under the panel bundle where the center of gravity has been indicated.
- Panel bundles greater than 20' should be lifted with a crane or forklift utilizing a spreader bar with nylon straps spaced approximately at 1/3 points.
- Do **not** use steel chokers of chains.
- Banding on bundles should be left intact until all lifting of panels is complete.
- Do not let straps slide on panel edges as the sharp edges will cut straps.

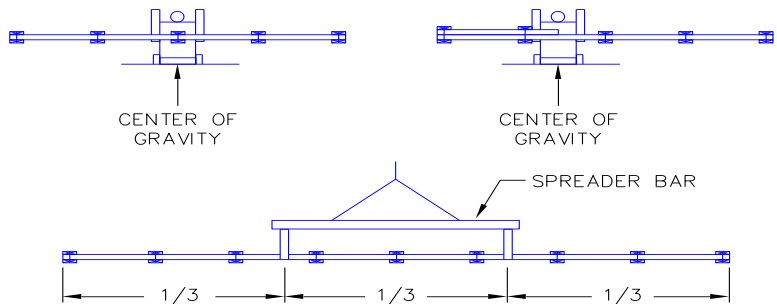

ILLUS. 1.3 LIFTING PANEL BUNDLES

WOOD CRATES

- Wood crates should be lifted with either a forklift at the "lift points" indicated on the crate or a crane utilizing a spreader bar with nylon straps. Straps should be located at the wood blocking on the bottom of crate.
- Lift one crate at a time.

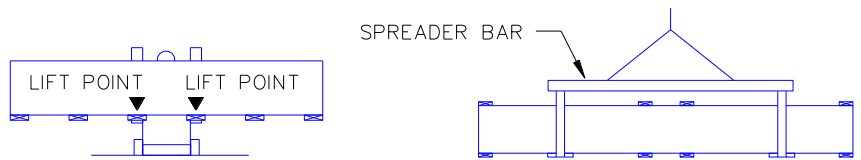

ILLUS. 1.4 LIFTING CRATES

1.H STORAGE

Outside job site storage of all building components should be limited to a short duration just prior to erection and when site conditions are favorable. Warehouse storage should be used when adverse field conditions or long-term storage is anticipated.

TRIM STORAGE CONSIDERATIONS

All trim components are shipped in a wooden crate with a covering of nylon reinforced paper. Trim components have a protective film on the colored surface that should not be exposed to rain and/or sunlight prior to installation. See Section 3.C for additional information concerning film on trim.

STORING COVERING

Short-term job site storage of roof and wall covering may be tolerated provided that care is taken to protect panel surfaces from trapped moisture.

Coated steel panels are subject to corrosion and discoloration if moisture becomes entrapped between panels. Inspect panels for entrapped moisture upon arrival at the job site and properly protect and store them in order to prevent accumulation of moisture between panels.

In addition to moisture due to rainfall, moisture can also form between panels due to condensation. When panels are not expected to be immediately installed, inside storage is recommended.

When outside storage is necessary, store in accordance with the following criteria:

- a. Store panels in a protected area, out of standing water and drifting snow, etc.
- b. When panels are stored on the ground, use a plastic ground cover to minimize condensation of moisture from the ground onto the panels.
- c. Raise the bundles off the plastic ground cover to prevent contact with water puddles, and allow for air circulation over, under, and through the bundles to resist creation of and promote the evaporation of any condensed moisture.
- d. Provide sufficient blocking to raise and support the bundles to prevent excessive bowing.
- e. Slope panels for drainage of moisture from the panels.
- f. Cover panels with a breathable waterproof cover, allowing for air circulation (do not wrap cover under panel bundles or restrict air movement).
- g. Inspect panels daily for moisture accumulation.
- h. If panel bundles contain moisture, the panels must be dried and restacked. Use care in restacking to not damage panels.
- i. Secure opened or restacked panel bundles to prevent damage.

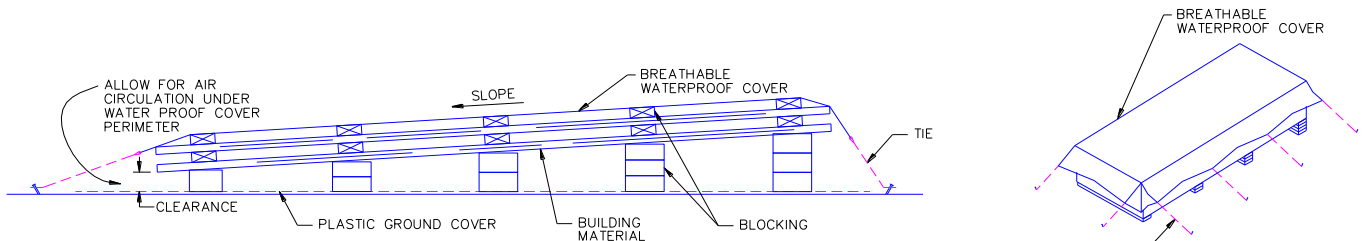

ILLUS. 1.5 FIELD STORAGE OF PANELS

STORING INSULATION

Insulation should not be delivered to the job site until panel erection is ready to begin. If insulation is to be stored at the job site, set it on blocks, off of the ground and covered for protection.

1.1 LAYOUT OF COMPONENTS

The careful unloading of building components and proper location around the building site will increase erection efficiency. By spot placement of components nearest their final use point, material handling time and labor will be reduced. The material layout shown below is a typical plan.

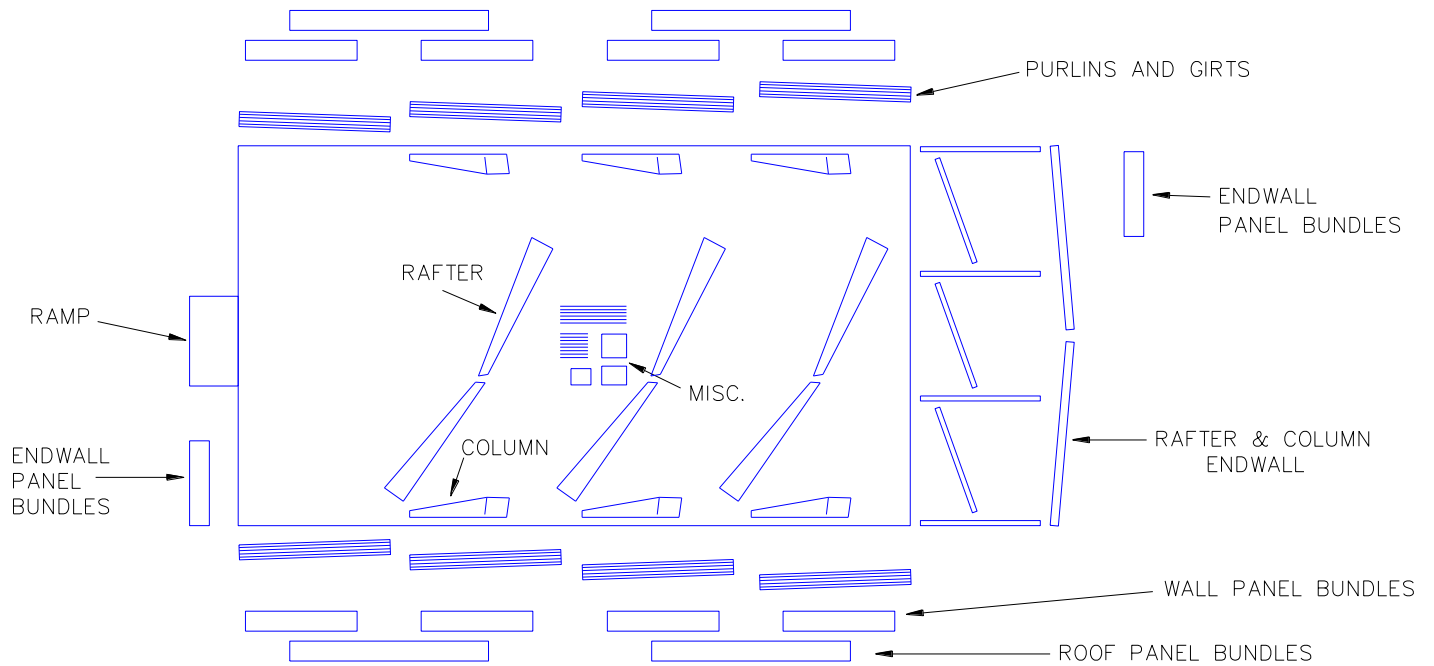

ILLUS. 1.6 COMPONENT SITE LAYOUT

All frame parts should be stored for easy access and erection with parts needed first on top. Place columns, rafters and crated components on blocking to prevent contact with ground. Block one end of members or crates higher to permit drainage. Rafters and columns should be laid on their flange edges with web parallel to the ground.

2 ERECTION SEQUENCE - FRAMING

2.A ANCHOR BOLT AND FOUNDATION CHECK

The foundation and the anchor bolts should be checked prior to delivery of the building. This will allow for corrections to be made before time to erect.

At the time bolts are checked, nuts and washers should be located and bolts should be cleaned and greased.

Bolts should be checked for projection, spacing, size, squareness and quantity.

When checking anchor bolts for squareness (see illustration below) the distance A to B must equal C to D and 1 to 2 must equal 3 to 4 in all bays.

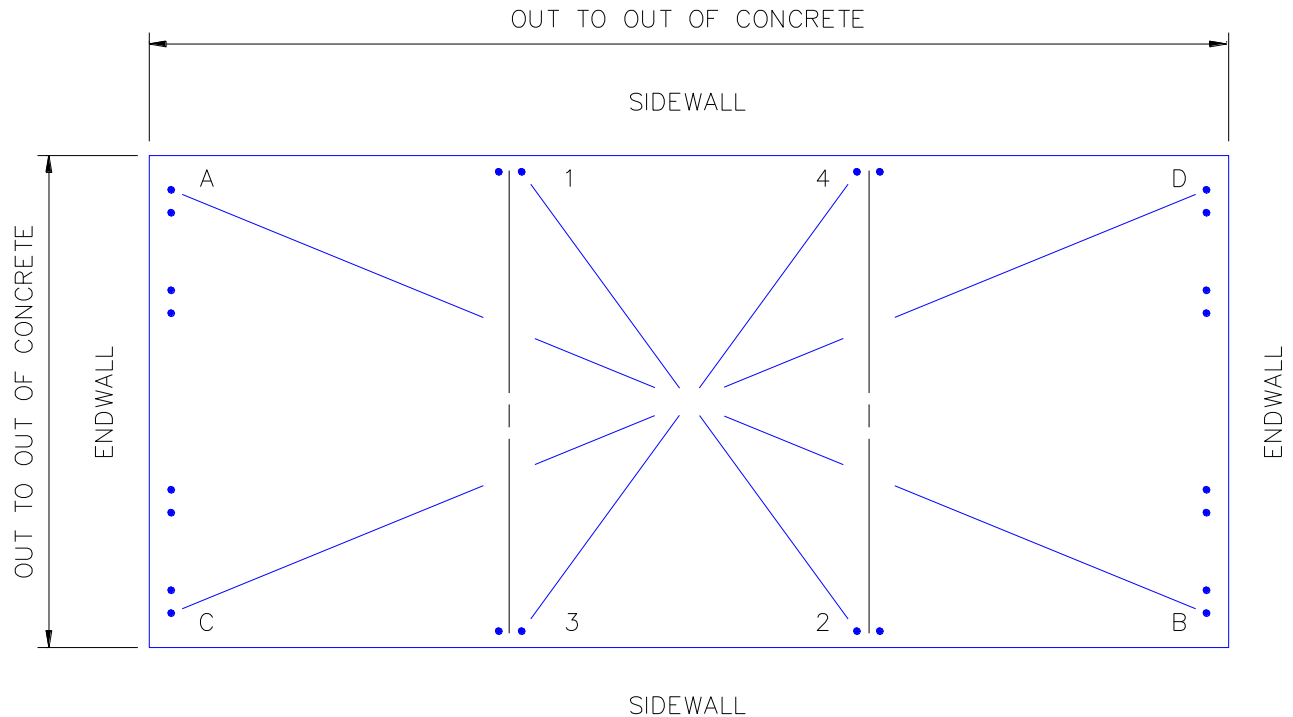

ILLUS. 2.1 CHECKING FOUNDATION

A check of the “out to out dimension” on the foundation will double check the span and building length.

Foundation should be cleaned at areas where columns are to be set. The edge of the concrete should be smooth to accept the placement of the base angle or base seal.

2.B ERECTION SEQUENCE

Prior to raising a component refer to the job erection drawings to confirm the location of that component. Mislocation of components can be costly in erection time (disassembling and re-erecting) and could result in structural failure.

SUGGESTED SEQUENCE

The following is an erection sequence which has been successfully used in erecting frame buildings. Variations may be required due to special circumstances or an erector may have developed other methods. The method actually utilized is the responsibility of the erector.

1. Erect the braced bay.
2. Erect adjacent bays.
3. Erect endwall and end bay.
4. Erect opposite endwall and end bay.
5. Final check.

The following erection sequence contains basic erection information.

Refer to the job erection drawing at all times for more specific information and details.

1. ERECT THE FIRST BRACED BAY

Raise the columns of the first braced bay, tightly connect all anchor bolts on columns and tie together by bolting on a girt and eave strut. Temporary bracing should be placed to provide stability until the entire bay, including permanent bracing, has been erected. Do not just rely on the permanent bracing, as it is designed to work with the fully assembled building and may not be adequate at all stages of construction.

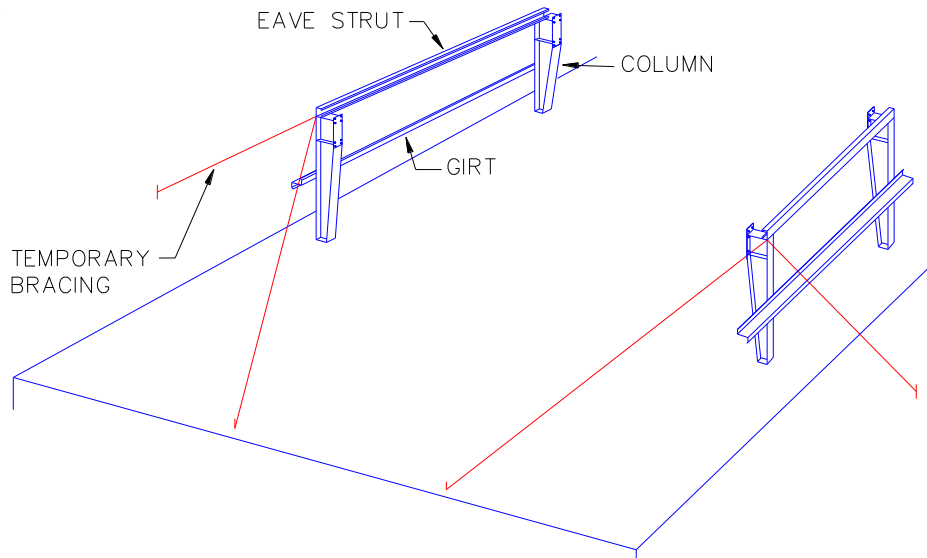

ILLUS. 2.2 ERECTING FIRST BAY

Assemble the rafter on the slab. Install all splice bolts and flange braces.

SAFETY PRECAUTION:
Stay well in the clear of loads being moved by any lifting device.

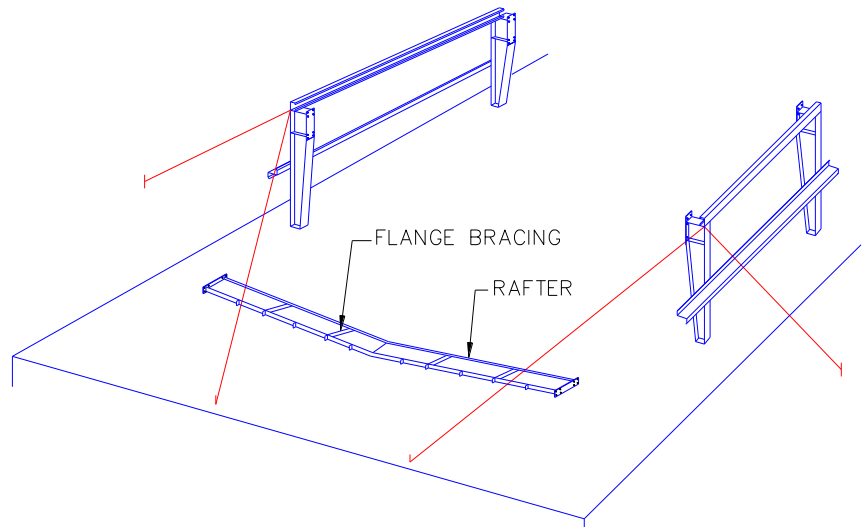

ILLUS. 2.3 ASSEMBLING RAFTER

Raise the assembled rafter, using a lifting method best suited for the size and weight of the assembled rafter. Bolt rafter to the column. Assemble and raise the second rafter, bolt in place.

After the first two frames are set and temporary bracing is in place, the purlins and girts should be installed (bolts should be finger tight). Flange braces can be attached to purlins and girts (see ILLUS. 2.4).

The sequence of erection and the stabilization of metal building components may be accomplished in different ways and is the responsibility of the erection professional.

SAFETY PRECAUTIONS:

Girt to column connections are not designed to support the weight of construction workers. Ladders or scaffolding should be used. Roof purlins and eave struts are unstable and subject to twist prior to installation of roof covering. Use approved tie offs, netting and rails when working on roof surfaces.

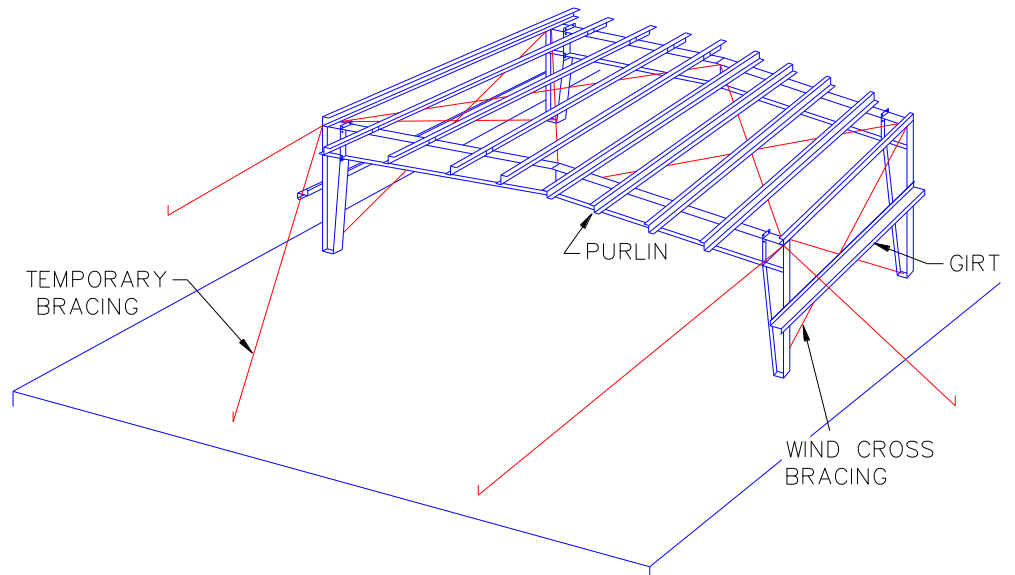

ILLUS. 2.4 COMPLETING FIRST BAY

INSTALL WIND BRACING

The wind x-bracing is assembled as follows:

Step No. 1

Locate the cable bracing assemblies as shown in ILLUS. 2.5. Hex nuts and washers are factory assembled on eye bolts and bracers are shipped separately.

Step No. 2

Remove nut and washer from eyebolts, insert eyebolt through slot in web. Install bracer, washer and nut on one end then stretch the cable bracing assembly to the other slot and assemble hardware on this end (see ILLUS. 2.6).

The lug on the bottom of the bracer should be positioned against the end of the slot in the direction of the wind bracing.

Step No. 3

One of the cable assemblies used on a sidewall end bay will be secured to the floor by four 3/4" diameter anchor bolts (see ILLUS. 2.7).

Step No. 4

For flush girt systems, a field located 13/16" x 2 1/2" long slot will be field cut into the girt webs to allow the cable bracing to pass through.

Step No. 5

Cable bracing should not be tightened until braced bay is plumb and square. Columns can be plumbed by using a carpenter's level or an instrument. Diagonal measurements (see ILLUS. 2.8) can be made to assure proper alignment of bay.

Step No. 6

After the bay is squared and the columns are plumb, tighten column anchor bolts, the knee and rafter splice bolts, the girt, purlin and eave strut bolts. Draw the cross-bracing taut by tightening the end nut (DO NOT OVERTIGHTEN CROSS-BRACING).

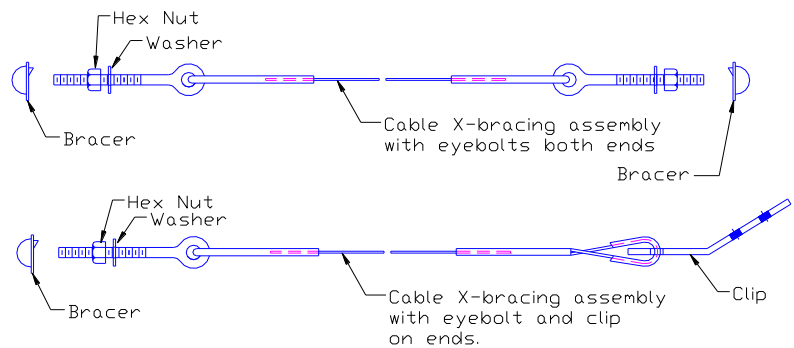

ILLUS. 2.5 CABLE ASSEMBLIES

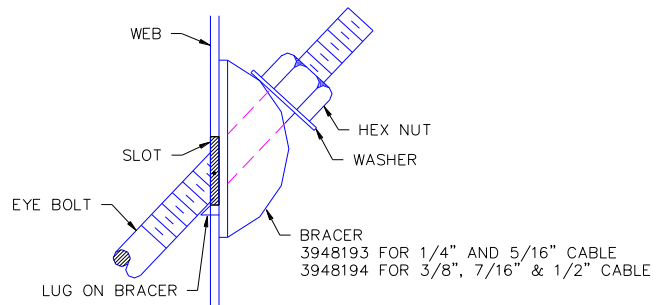

ILLUS. 2.6 ASSEMBLING HARDWARE ON EYEBOLT

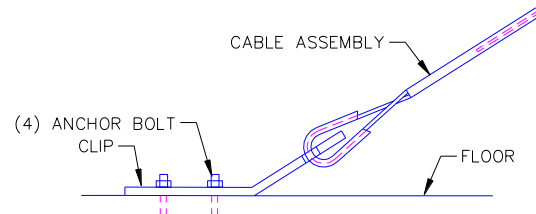

ILLUS. 2.7 ASSEMBLING CLIP TO FLOOR

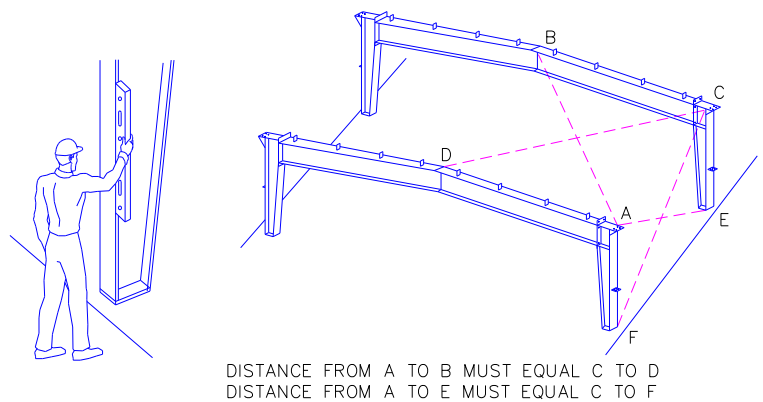

ILLUS. 2.8 PLUMB AND SQUARE

2. ERECT ADJACENT BAYS

Bays adjacent to the interior braced bay may be erected next. If the adjacent bay is an end bay, see endwall erection instructions.

After each interior frame is erected, install enough girts, purlins and eave struts to stabilize the frame before moving on to the next bay.

After all interior bay purlins and eave struts are installed, install all flange braces and tighten bolts.

3. ERECT ENDWALL

The location and quantity of endwall columns will vary due to building size. The width of the building will also determine how much of the endwall can be assembled on the ground.

For narrow width buildings, the entire rafter and column endwall may be assembled on the ground.

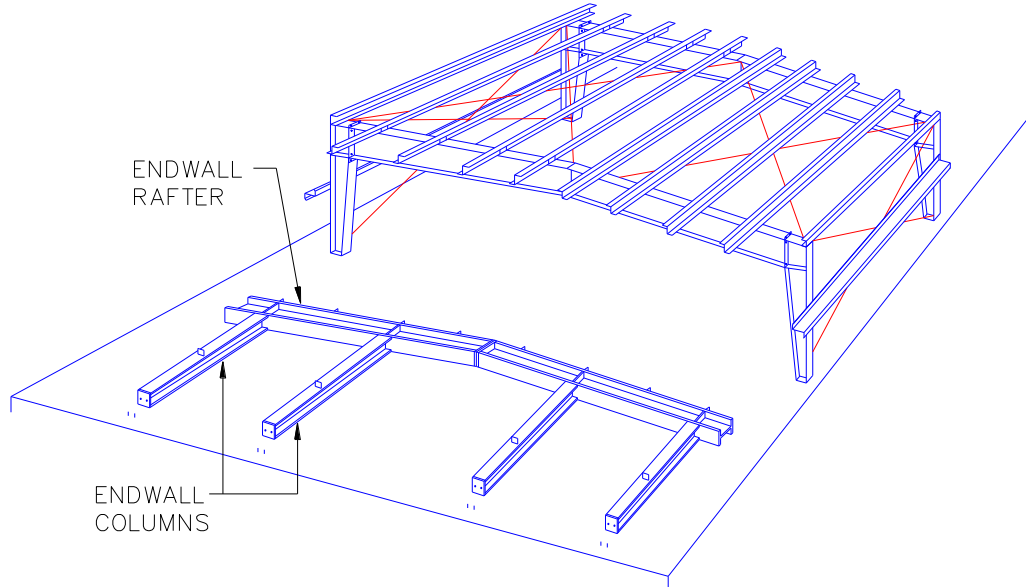

ILLUS. 2.9 ENDWALL ON NARROW BUILD WIDTH

Once the endwall is assembled, tilt in to place as shown in ILLUS. 2.10 and attach eave struts and purlins closest to the column to stabilize the frame. Plumb and square end frame and install remaining purlins, girts, rake angles and flange braces.

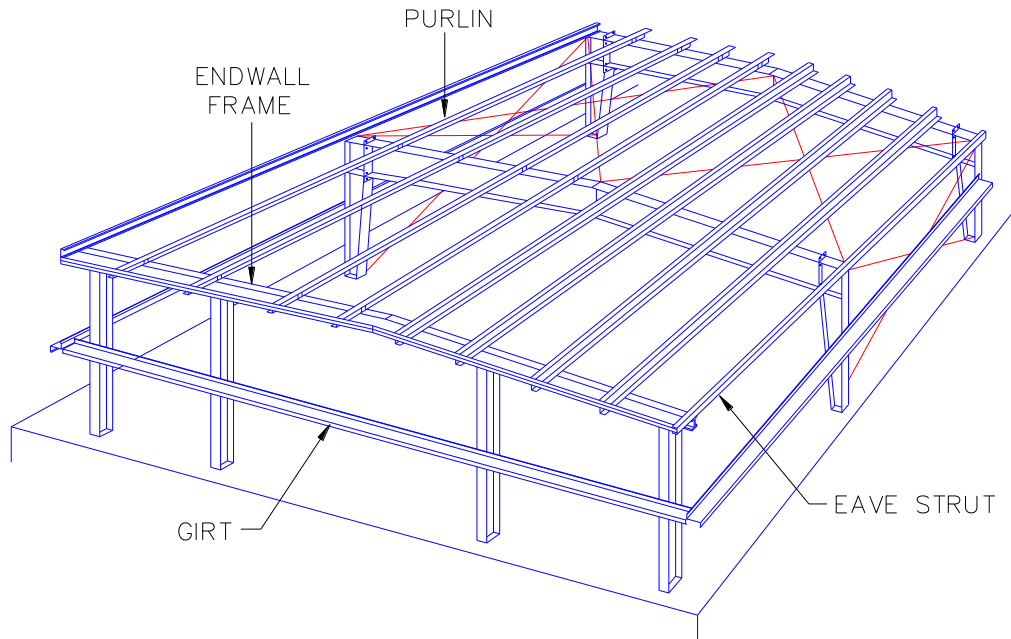

ILLUS. 2.10 ENDWALL IN PLACE

On wide buildings where it is not practical to raise the entire endwall; a suitable endwall module may be assembled on the ground, then tilted up into position and stabilized with eave strut and purlins (see ILLUS. 2.11). Assemble and erect the remaining modules in a likewise manner.

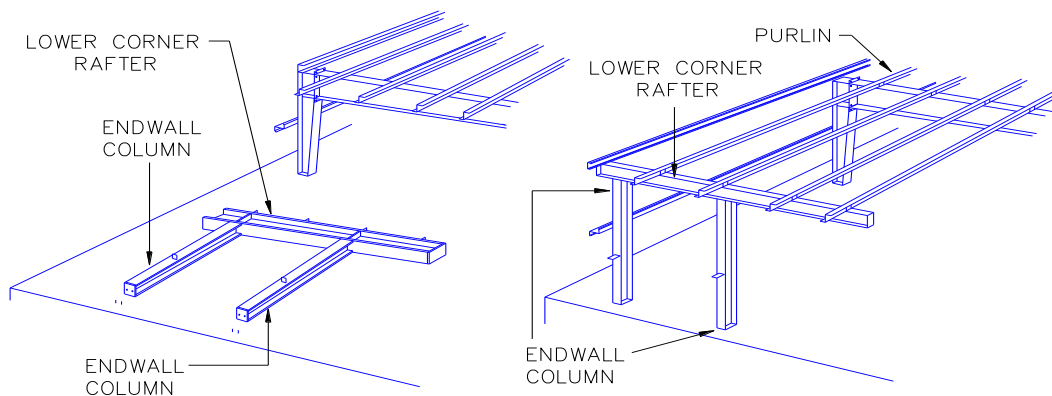

ILLUS. 2.11 ENDWALL MODULE IN PLACE

4. ERECT OPPOSITE ENDWALL

When the last interior bay is complete, erect the endwall frame as described previously and then complete end bay.

5. FINAL CHECK

Before proceeding with sheeting, inspect the building to determine if all components have been installed correctly and all fasteners are installed and tightened properly.

2.C TIGHTENING A325 BOLTS

See ERECTION DRAWINGS for information on tightening A325 bolts.

2.D GENERAL FRAMING

The illustration below is intended as an aid in the identification and location of structural members and components used in the construction of frame buildings. Variances will occur depending upon type of building. Some building components such as flange braces, clips, angles and brackets are not shown.

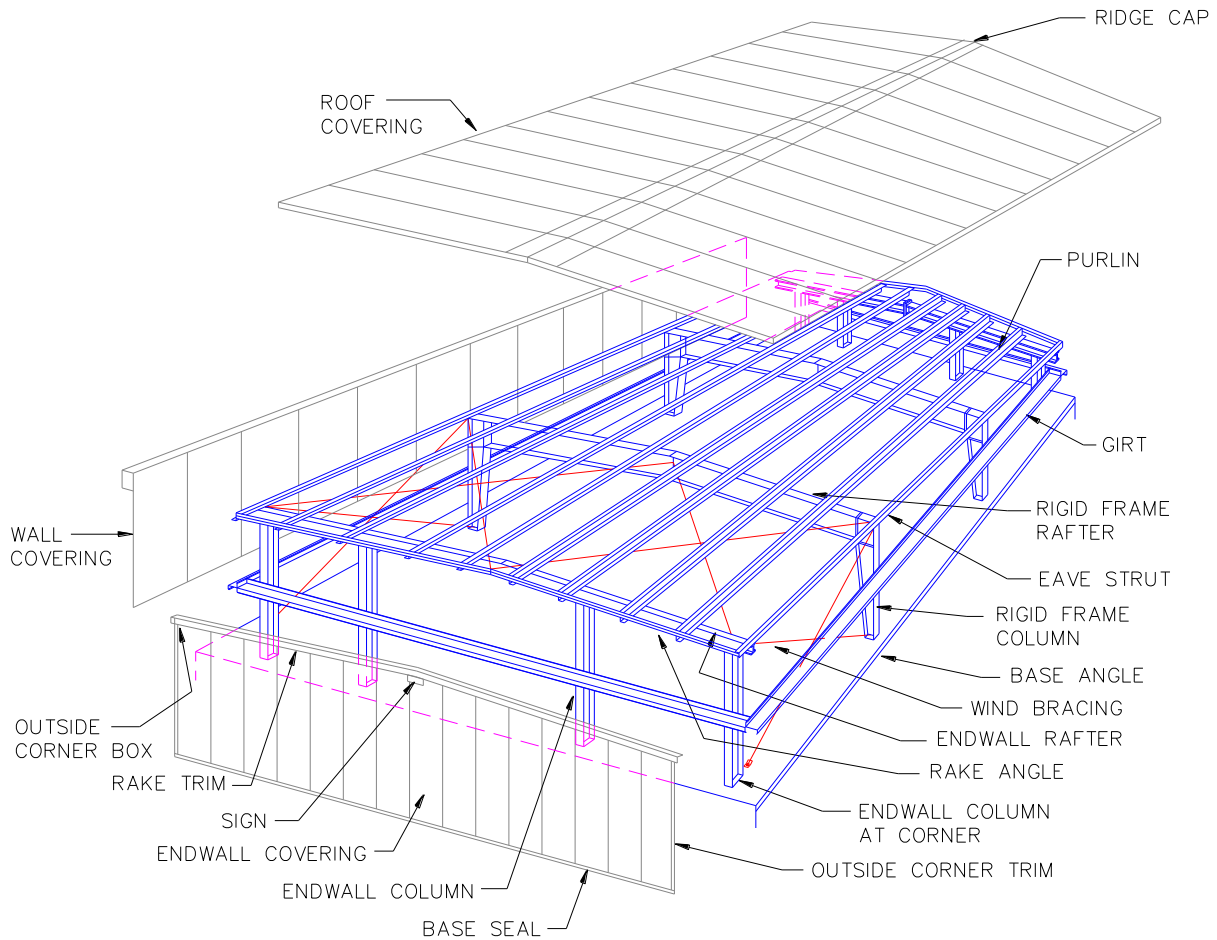

ILLUS. 2.12 GENERAL FRAMING AND COVERING

3 TRIM COMPONENTS

3.A TRIM IDENTIFICATION

The standard trims shown below will be used with ADP-1 wall panels.

TITLE	PART NO.	PROFILE	DESCRIPTION	WHERE USED
Base Seal	TW11-20		<ul style="list-style-type: none"> • 26 Ga. Material • 20'-6" Length • Bent two at a time 	<ul style="list-style-type: none"> • Base of wall panel perimeter of building
Base angle/seal	TW20-20		<ul style="list-style-type: none"> • 18 Ga. Material • 20'-6" Length 	<ul style="list-style-type: none"> • Base of wall panel perimeter of building

Outside Corner Trim	TW1-12 TW1-16 TW1-20		<ul style="list-style-type: none"> • 26 Ga. Material • 12'-6", 16'-6" or 20'-6" Lengths • Bent two at a time 	<ul style="list-style-type: none"> • Corner of building with ADP-1 panels • Start dimensions of 1" or less
	TW45-12 TW45-16 TW45-20		<ul style="list-style-type: none"> • 26 Ga. Material • 12'-6", 16'-6" or 20'-6" Lengths • Bent two at a time 	<ul style="list-style-type: none"> • Corner of building with ADP-1 panels • Start dimensions greater than 1" but no more than 3 1/2"
	TW46-12 TW46-16 TW46-20		<ul style="list-style-type: none"> • 26 Ga. Material • 12'-6", 16'-6" or 20'-6" Lengths 	<ul style="list-style-type: none"> • Corner of building with ADP-1 panels • Start dimensions greater than 3 1/2" but less than 6"
Inside Corner Trim	TW55-12 TW55-16 TW55-20		<ul style="list-style-type: none"> • 26 Ga. Material • 12'-6", 16'-6" or 20'-6" Lengths • Bent two at a time 	<ul style="list-style-type: none"> • Inside corner of two buildings with ADP-1 panels • Maximum 6" start dimensions
Coped Flashing	TE31		<ul style="list-style-type: none"> • 26 Ga. Material 	<ul style="list-style-type: none"> • Top of ADP-1 wall panel, behind eave and rake trims
Drip Cap	TW13		<ul style="list-style-type: none"> • 26 Ga. Material • 3'-11" Length 	<ul style="list-style-type: none"> • Along header of 3070 walk door
	TW14		<ul style="list-style-type: none"> • 26 Ga. Material • 6'-11" Length 	<ul style="list-style-type: none"> • Along header of 6070 walk door
Drip Cap	TW21-12 TW21-16 TW21-20		<ul style="list-style-type: none"> • 26 Ga. Material • 12'-7", 16'-7" and 20'-7" Lengths 	<ul style="list-style-type: none"> • Along header of framed openings
Jamb Trim Stiffener	TW15		<ul style="list-style-type: none"> • 26 Ga. Material • 7'-3 1/4" Length 	<ul style="list-style-type: none"> • Along jambs of walk doors
	TW23-12 TW23-16 TW23-20		<ul style="list-style-type: none"> • 26 Ga. Material • 12'-6", 16'-6" and 20'-6" Lengths • Bent two at a time 	<ul style="list-style-type: none"> • Along jambs on framed openings

Jamb Trim	TW16		<ul style="list-style-type: none"> • 26 Ga. Material • 7'-3 1/4" Length 	<ul style="list-style-type: none"> • Along jambs of walk doors
	TW24-12 TW24-16 TW24-20		<ul style="list-style-type: none"> • 26 Ga. Material • 12'-6", 16'-6" and 20'-6" Lengths • Bent two at a time 	<ul style="list-style-type: none"> • Along jambs on framed openings
	Sill Trim		<ul style="list-style-type: none"> • 26 Ga. Material • 3'-10" and 6'-10" Lengths 	<ul style="list-style-type: none"> • Along sills of framed openings of 6'-4" or less
Sill Trim	TW71 TW72		<ul style="list-style-type: none"> • 26 Ga. Material • 12'-6", 16'-6" and 20'-6" Lengths 	<ul style="list-style-type: none"> • Along sills of framed openings greater than 6'-4"
	TW58-12 TW58-16 TW58-20		<ul style="list-style-type: none"> • 26 Ga. Material • 3'-10" and 6'-10" Lengths 	<ul style="list-style-type: none"> • Along sills of framed openings of 6'-4" or less
	Jamb Cover		<ul style="list-style-type: none"> • 26 Ga. Material • 12'-6", 16'-6" and 20'-6" Lengths 	<ul style="list-style-type: none"> • Around framed openings with 8" deep members
Jamb Cover	TW81-12 TW81-16 TW81-20		<ul style="list-style-type: none"> • 26 Ga. Material • 12'-6", 16'-6" and 20'-6" Lengths 	<ul style="list-style-type: none"> • Around framed openings with 10" deep members
	TW19-12 TW19-16 TW19-20		<ul style="list-style-type: none"> • 26 Ga. Material • 12'-6", 16'-6" and 20'-6" Lengths 	<ul style="list-style-type: none"> • Around framed openings with 8" deep members
	Jamb Cover		<ul style="list-style-type: none"> • 26 Ga. Material • 12'-6", 16'-6" and 20'-6" Lengths 	<ul style="list-style-type: none"> • Around framed openings with 10" deep members

3.B HANDLING LONG TRIM

When removing long trim from the shipping crate and during installation, care should be taken to avoid damage caused by buckling. Lift with two or more people, do not pick trim up by ends.

3.C PROTECTIVE FILM REMOVAL

Trim components have a protective film on the colored surface that must be removed prior to installation. Prolonged exposure (more than 3 weeks) to rain and/or sunlight will adversely affect the protective film making removal difficult.

REMOVAL INSTRUCTIONS
 When film is being removed from trim having a hem along its edge, the film should be peeled off along the entire end. This includes the 3/8" hemmed area, on the back side. Pull the entire film strip at a constant rate. Do **NOT** try to rip the film off as it will tend to tear at the hemmed edge and corners leaving a strip that will have to be removed separately.

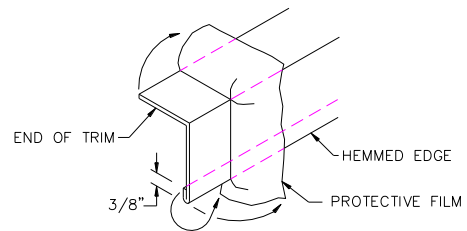

ILLUS. 3.1 REMOVING FILM

3.D TOUCH-UP PAINT

With continued improvements to painted material applications and color matching methods via paint retailers, scanning a color sample is one of the fastest ways to arrive at the correct matched touch-up paint color for Behlen Building Systems sheeting or trim.

Be certain to request an appropriate high performance acrylic / direct-to-metal base for the color match paint. A Sherwin Williams recommended base noted below. Also indicate to your paint retailer that the touch-up paint will be applied to either a Fluropon 70% Kynar or a siliconized polyester finish. Reference your Behlen Buildings Systems drawings cover page for color name and cross reference with your Behlen color chart as necessary to confirm finish type. Note, for a proper color scan and match, the paint sample must physically be a metal sample of painted material. DO NOT USE the Behlen color chart for scanning paint color match.

If the local retailer is a Valspar/Sherwin Williams dealer, an alternate way of arriving at a color match other than scanning can be achieved as follows: Use the Valspar / Sherwin Williams Codes noted below and advise paint retailer of your SHER-COLOR request utilizing the appropriate base option. These bases can be tinted to light and dark colors. Copies of these base specifications noted below.

**USE SHER-CRYL HPA (HIGH PERFORMANCE ACRYLIC) or PRO INDUSTRIAL DTM
ACRYLIC SEMIGLOSS.**

Valspar/Sherwin Williams Fluropon 70% Kynar Colors Only

Charcoal (432R1065)

Natural Evergreen (435RZ263)

Patrician Bronze (437R813)

Regal Blue (436RZ1100)

Regal White (431A886)

Surrey Beige (433B365)

Ultra Brite Red (434A986)

If the local retailer is not a Valspar / Sherwin William affiliate or the color you are trying to match is not available with an SW paint Kynar color code, please have them scan your metal paint sample to arrive at appropriate color formula. Feel free to share with the retailer the Sherwin Williams recommended bases (specifications attached) for use in arriving at a comparable/equivalent type for the brand paint your retailer offers.

GENERAL NOTES: Touch-up paint should be use sparingly and only to cover up areas where the paint has been removed. Areas to be touched up should be wiped with diluted mineral spirits to remove dirt, wax and other contaminants then lightly sanded by using 3M block (medium grit) to roughen the painted surface adjacent to the scratched area before colored touch-up paint is applied.

Aerosal or spray applications are not recommended for blemish or scratch repairs. The best tool for this type of repair is a high quality small bristle or foam brush.

SPECIAL NOTE: Touch-up paints are an air-dry system and application unlike the original color application to the base metal. As such, differential fading and/or color mismatch can develop over long periods of time due to general weathering and UV exposure of the touch-up area compared to the balance of the painted panel surface. A re-touch of the area may be required based on a current color match at that time.

4 FASTENERS

4.A IDENTIFICATION AND USAGE

The information presented herein is provided as a supplement to the job erection drawings and is typical for most buildings. Variations may occur because of special building requirements. Always refer to the job erection drawings which will govern specific part and assembly arrangements and applicable illustration details.

Fasteners will be identified by a "label" or circle with a numerical number inside of it. These labels and numbers will correspond to the ID number in the FASTENER SCHEDULE in the job erection drawings.

STITCH SCREW

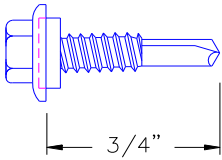

ILLUS. 4.1 STITCH SCREW

Label

②

Part Number

(Plated) 3228100

(Colored) 3228100__

Code

Description

Screw 1/4" x 3/4" FL-TP SD WW

Self-Drilling screw with a flat-top under cut 5/16" hex head and EPDM sealing washer

Applications:

All wall panel sidelaps

TRIM SCREW

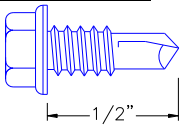

ILLUS. 4.2 TRIM SCREW

Label

⑥

Part Number

(Plated) 3228099

(Colored) 3228099__

Code

Description

Screw #8 x 1/2" HWH SD NW

Self-drilling screw with a 1/4" hex head and no washer.

Applications:

Sidelap of corner trim and adjacent wall panel. Endlap splices of corner trim and jamb trims.

STRUCTURAL SCREWS

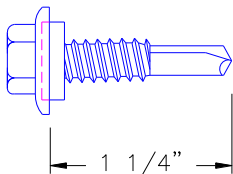

ILLUS. 4.3 STRUCTURAL SCREW

Label

④

Part Number

(Plated) 3228101

(Colored) 3228101__

Code

Description

Screw #12 x 1 1/4" FL-TP SD WW

Self-drilling screw with a flat-top undercut 5/16" hex head and EPDM sealing washer

Applications:

To attach wall panels to secondary members.

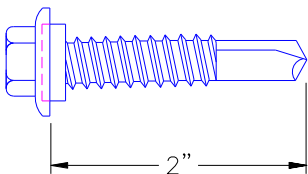

ILLUS. 4.4 STRUCTURAL SCREW

Label

⑰

Part Number

(Plated) 3228102

(Colored) 3228102__

Code

Description

Screw #12 x 2" FL-TP SD WW

Self-drilling screw with a flat-top undercut 5/16" hex head and EPDM sealing washer

Applications:

To attach wall and covering containing 6" thick insulation or when specified on Frame Building Order Form for attaching wall panels to secondary members.

4.B FASTENER PATTERNS

1. Structural screw patterns for ADP-1 panels.

Use the pattern (BELOW) at the following location.

- Along girt lines

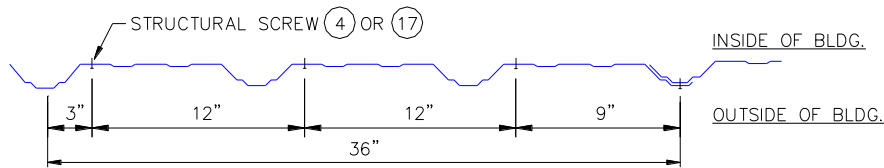

Use the pattern (BELOW) at the following location.

- Base of wall panel
- Top of wall panel at eave strut
- Top of wall panel at endwall rake
- Top of wall panel under endwall gable extension
- Along drip cap at header
- Top of wall panel at sill

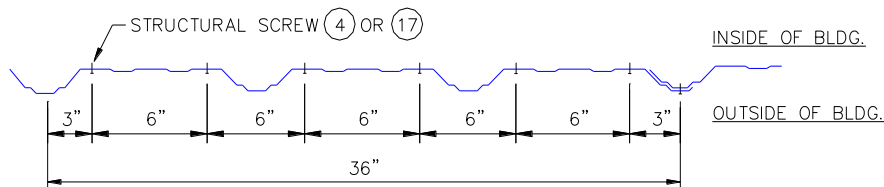

ILLUS. 4.5 STRUCTURAL SCREW PATTERNS FOR ADP-1 PANELS

2. Stitch screw patterns for ADP-1 panels.

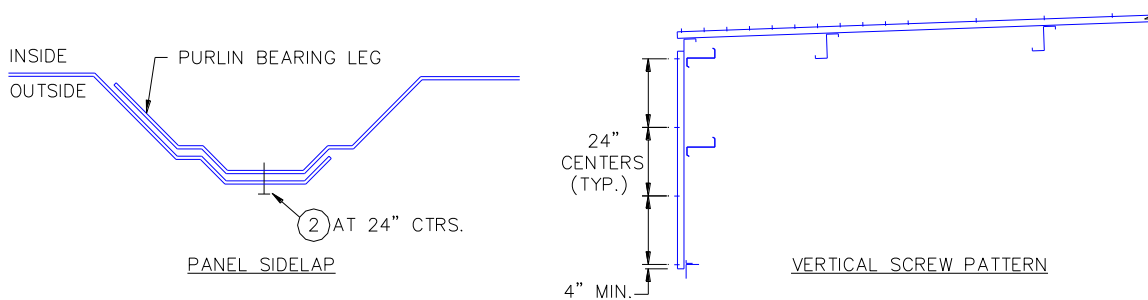

ILLUS. 4.6 STITCH SCREW PATTERN FOR ADP-1 PANELS

The sidelap of ADP-1 wall panels should be constructed in the field so that the "Purlin Bearing Leg" on the panel will be on the inside of the building.

3. Trim screw pattern for ADP-1 panels

The sidelap of outside corner trim to adjacent ADP-1 panels will be at 24" centers, similar to stitch screws above.

4.C SEATING OF FASTENERS

When using any self-drilling screw, apply sufficient torque to seat the washer correctly. Do not overdrive the fastener.

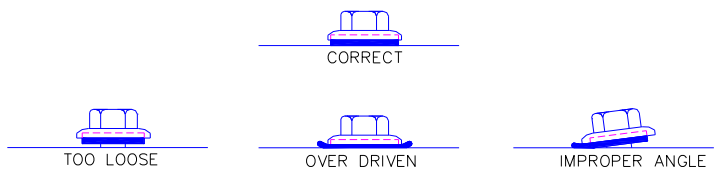

ILLUS. 4.7 SEATING FASTENERS

4.D TROUBLE SHOOTING GUIDE

The following information is designed to assist you in correcting problems that may be encountered while installing the self-drilling screws. Listed below are some potential problems, causes and solutions.

If no solution to the problem can be found in the field, contact:
 Behlen Mfg. Co. (800) 228-0340
 Atlas Bolt & Screw Technical Services (800) 321-6977

- PROBLEM:** Rounding off hex head.

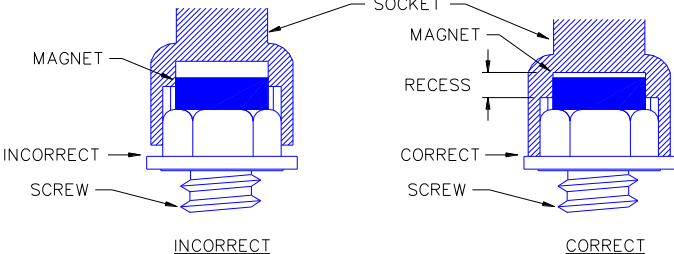
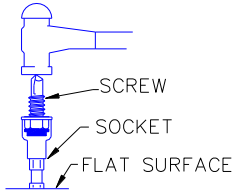
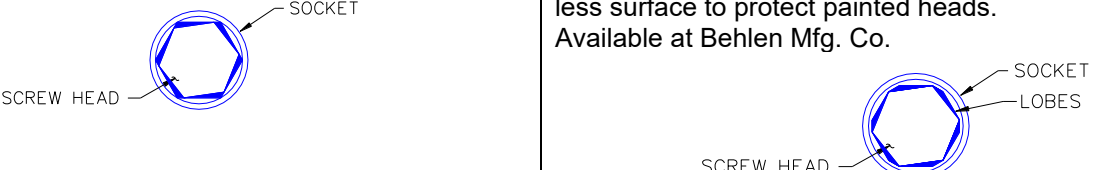
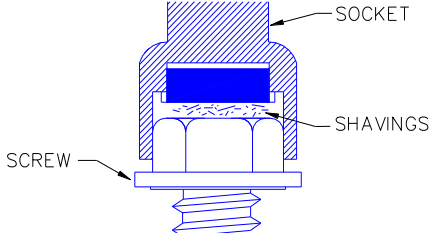
CAUSE	SOLUTION
<p>Improper socket to hex contact.</p> 	<p>Set the proper magnet depth by using a screw and hammer to drive the magnet further into the recess of the socket.</p> 
<p>Improper engagement of socket to hex head.</p> 	<p>Replace socket with new one which has the new "lobe design" which provides a positive grip while contacting less surface to protect painted heads. Available at Behlen Mfg. Co.</p>
<p>Build-up of metal shavings in socket.</p> 	<p>Use a small plug of tape mastic to remove metal shavings.</p>
<p>Socket is worn causing screw to wobble.</p>	<p>Replace socket with new one.</p>
<p>Socket size does not fit approximately to screw head.</p>	<p>Check whether a 5/16" hex or 3/8" hex is being used.</p>

2. **PROBLEM:** Burning off or rounding of drill point.

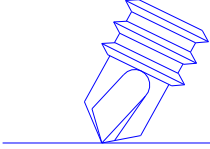
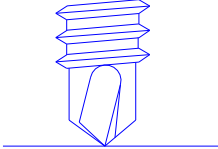
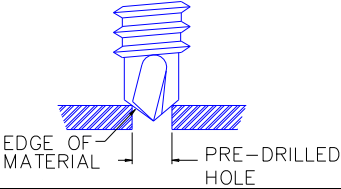
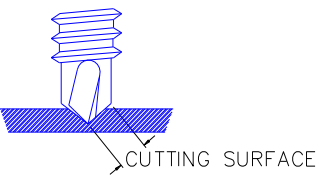
CAUSE	SOLUTION
Forcing screw in by applying too much pressure.	Allow the drill point to do work.
Not keeping fastener perpendicular to surface being drilled.	Reposition screw/screw gun into a vertical position.
 <p style="text-align: center;">INCORRECT</p>	 <p style="text-align: center;">CORRECT</p>
Incorrect drill point of material thickness being drilled.	Check the size/part number of screw being used with erection information supplied with job.
Improper speed (RPM) of screw gun.	Use 1800 RPM screw gun for best results.
Installing a self-drilling screw into a pre-drilled hole. The cutting surface of the screw will be blunted by the edge of the material.	Allow the screw point to drill hole with entire drill point cutting surface.
	

3. **PROBLEM:** Head separation (Head popping off)

CAUSE	SOLUTION
Incorrect application for screw. Stitch screw used in structural application.	Check the size/part number of screw being used with erection information supplied with job.
Over-torquing the screw.	Use depth sensing nose piece to allow proper seating of fastener.

4. **PROBLEM:** Head shavings on panel, causing red rust and corrosion.

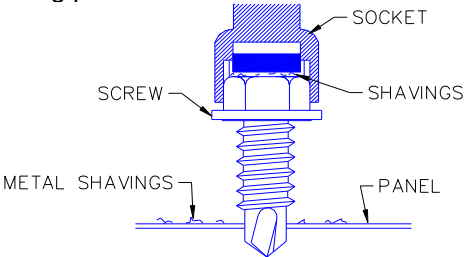
CAUSE	SOLUTION
Steel body screws become magnetized by magnetic socket insert, metal shavings attach to screw and spin onto panel.	Remove build-up of metal shavings in socket so that metal chips will come off the panel and adhere to the socket when screw gun is withdrawn.
The act of installing screws causes metal shavings to lay on surrounding panel surface.	Blow off loose shavings or use soft cloth to gently wipe off shavings from panel surface.
	

4.E ATLAS RECOMMENDATIONS



STOP . . . PLEASE READ

**RECOMMENDED INSTALLATION FOR SELF-DRILLING
TAPPING FASTENERS TO INSURE FASTENER PERFORMANCE**

- * Apply with 1800 RPM electric screw gun.
- * Drive socket size must fit appropriately to fastener head.

Socket Types:

1. **Super Star Socket** - Used for long-life non-magnetic screw heads. Can be used with carbon screw to avoid drill chips collecting on magnetic sockets.

Behlen Part No. - 1/4" (3518045) 5/16" (3518046) 3/8" (3518047)

2. **Non-magnetic** - Used by erectors on roofing applications, mainly to avoid drill chips collecting in sockets.
Special Order - 1/4" 5/16" 3/8"

Drilling/Driving fastener must be held perpendicular to the fastening surface.

Self-Drilling fasteners should not be forced in. Allow the drill point to do the work.

- CAUTION -

Over-torquing may result in fastener separation/failure (head popping off).
Care should be exercised during installation.
Torque of 30-60 in. lbs. Based on fastener size and application.

FOR APPLICATION SUPPORT, CONTACT:
ATLAS BOLT & SCREW TECHNICAL SERVICES (800) 321-6977
Behlen Mfg. Co. (800) 228-0340

- * 1800 RPM screw guns and sockets are available at your local tool house or from:
Dynamic Fasteners 1-800-821-5448

5 COVERING AND TRIM

Proper and careful erection of the covering and trim play a most important part in the look and integrity of the completed structure. The following items should be verified before placement of covering.

1. The building should be square and plumb.
2. All structural bolts should be tightened.
3. All flange braces should be properly installed.
4. Wind cross bracing must be installed and tensioned.

Field cutting of panels and trim should be avoided where possible. If field cutting is required, the panel or trim component must be cut with nibblers, snips or shears to prevent edge rusting. Do not cut components with saws, abrasive blades, grinders or torches.

5.A ALIGNING GIRTS

Due to the weight of girt material, temporary wood blocking should be secured between the girts (see ILLUS. 5.1) to bring girts into a horizontal plane.

SAFETY PRECAUTION:

Girt to column connections are not designed to support the weight of construction workers. Ladders or scaffolding should be used.

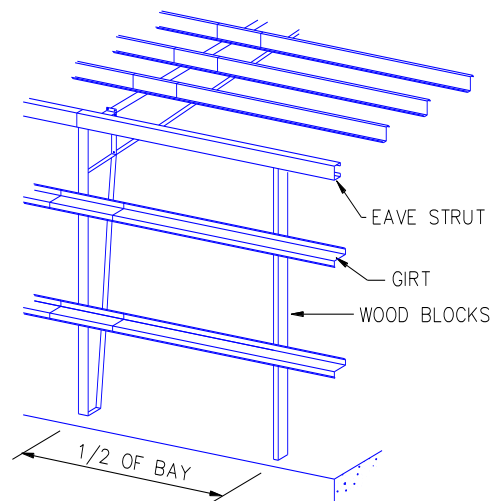

ILLUS. 5.1 TEMPORARY BLOCKING

5.B BLANKET INSULATION

The proper location and installation of blanket insulation and its vapor retarder (facing) is important to insure the performance of the vapor barrier, some guidelines are listed below.

1. Insulation is unrolled with the facing to the inside or warm side of the insulating surface of the building.
2. Any small holes or tears in the facing should be repaired as they will allow moisture to penetrate into the insulation.
3. Insulation seams are sealed by pulling the adjoining facing tabs upward at the joint, aligning the top edges of the two tabs and stapling together at approx. 12" centers (see ILLUS. 5.2). Fold the tab over again and staple at 4" centers (see ILLUS. 5.3).

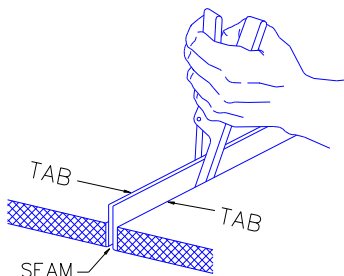

ILLUS. 5.2 STEP NO. 1

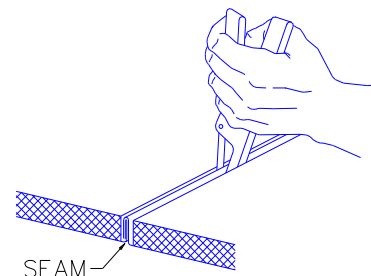

ILLUS. 5.3 STEP NO. 2

- This seam can be further sealed with a strip of tape (see ILLUS. 5.4).

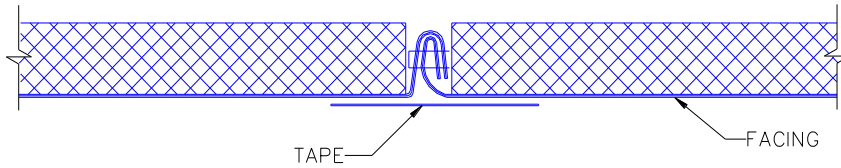

ILLUS. 5.4 (OPTIONAL) TAPED JOINT

- If the roll of insulation is not long enough, and an end splice is necessary, strip insulation back 2" from the facing forming a tab on each end. Staple ends together at 12" centers as shown in ILLUS. 5.2, then fold again and staple at 4" centers (see ILLUS. 5.3). Optional taped joint can be used (see ILLUS. 5.4). The end splice should be made directly over a girt flange.
- During erection, when necessary, fold and tape the facing at the end of the blanket to prevent absorbing excessive moisture (see ILLUS. 5.5). On insulation thickness greater than 3", some insulation should be stripped off before folding facing over (see ILLUS. 5.6).

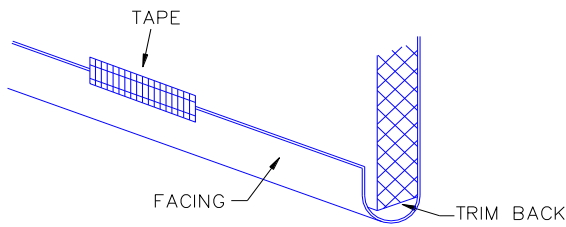

ILLUS. 5.5 FOLD AND TAPE FACING

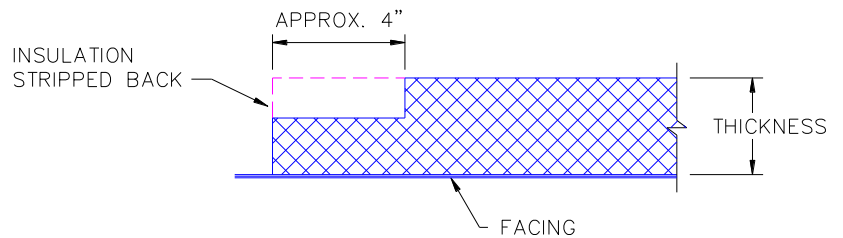

ILLUS. 5.6 REMOVE INSULATION

- Cut wall insulation length to allow for the wall height plus enough extra so that the base may be folded and taped (see ILLUS. 5.5 & ILLUS. 5.8). The top will be tape to eave strut or when applicable the rake angle on endwall (see ILLUS. 5.7).

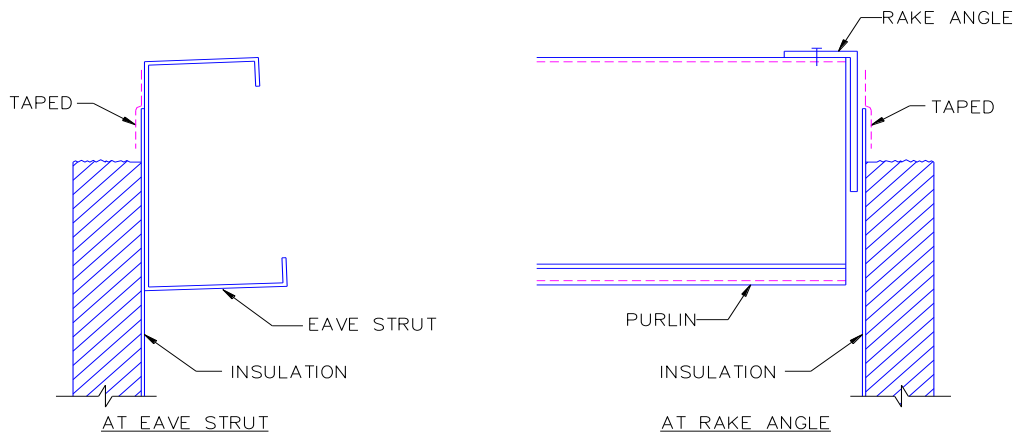

ILLUS. 5.7 INSULATION TAPED AT TOP

Stop insulation at least 1 inch above the bottom edge of wall panel.

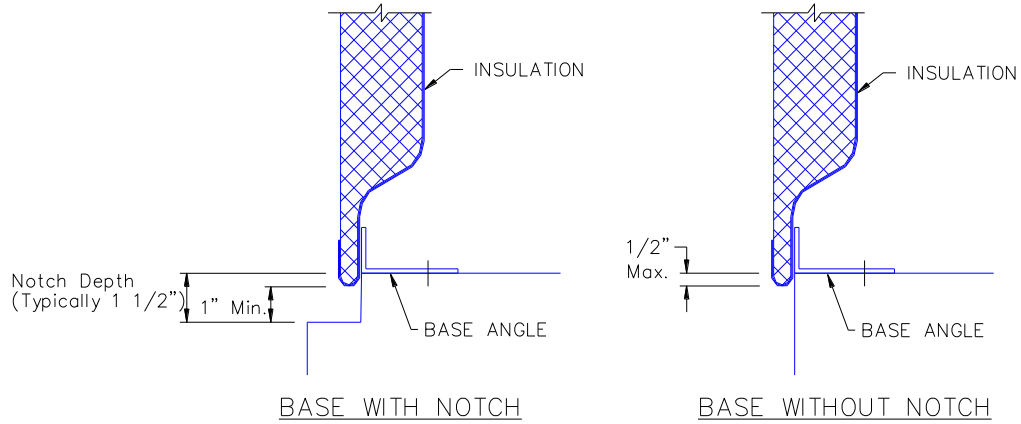

ILLUS. 5.8 INSULATION AT BASE

8. Wall insulation should be started at a sidewall corner. The first run of insulation should start 6" beyond the corner (see ILLUS. 5.9). This will allow the corner to be made easily.

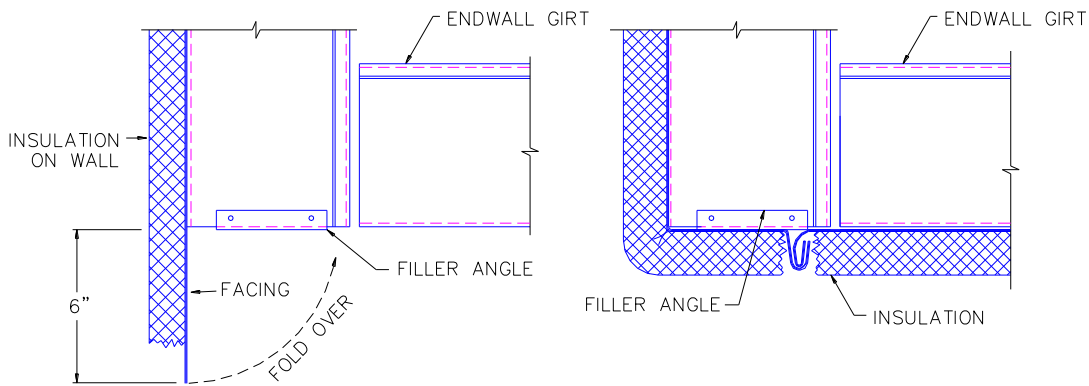

ILLUS. 5.9 INSULATION AT CORNER

9. Once the first run of insulation is correctly positioned, sidewall sheeting may start. Square placement of the first run of blanket insulation is important to the speed and neatness with which succeeding rolls may be placed. Remember to tension the insulation to provide a taut, smooth inside surface.
10. To contain insulation around a framed opening, the following methods can be used.

AT HEADER

Strip insulation from facing, place facing between panel and vertical leg of drip cap.

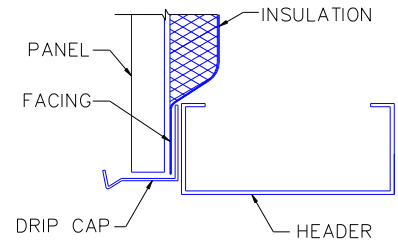

ILLUS. 5.10 AT HEADER

AT SILL

Strip insulation from facing, place facing between panel and front face of sill.

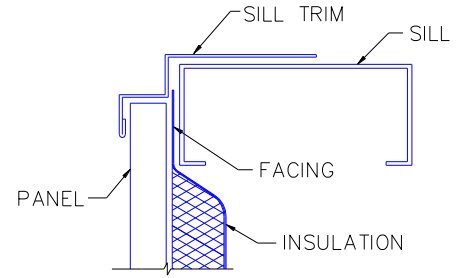

ILLUS. 5.11 AT SILL

AT JAMB

Strip insulation from facing, place facing between ADP-1 panel and jamb.

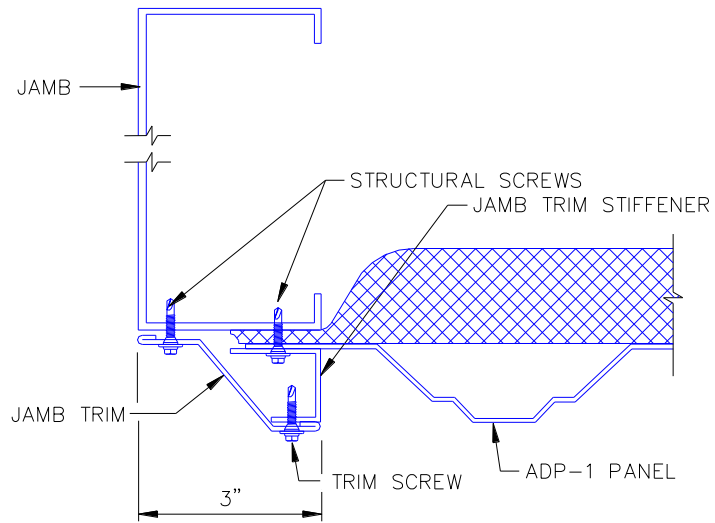

ILLUS. 5.12 AT JAMBS

5.C TRIM AT BASE OF PANEL

Two types of trim can be used at the base of wall panels Base Seal and One-Piece Base Angle/Seal. Both styles of trim will require field cutting at the corner of the building.

1. BASE SEAL

Base seal can be used with a base angle or base channel. Ends of base seal should be lapped 2". Base seals should be cut at the corners to give a finished appearance.

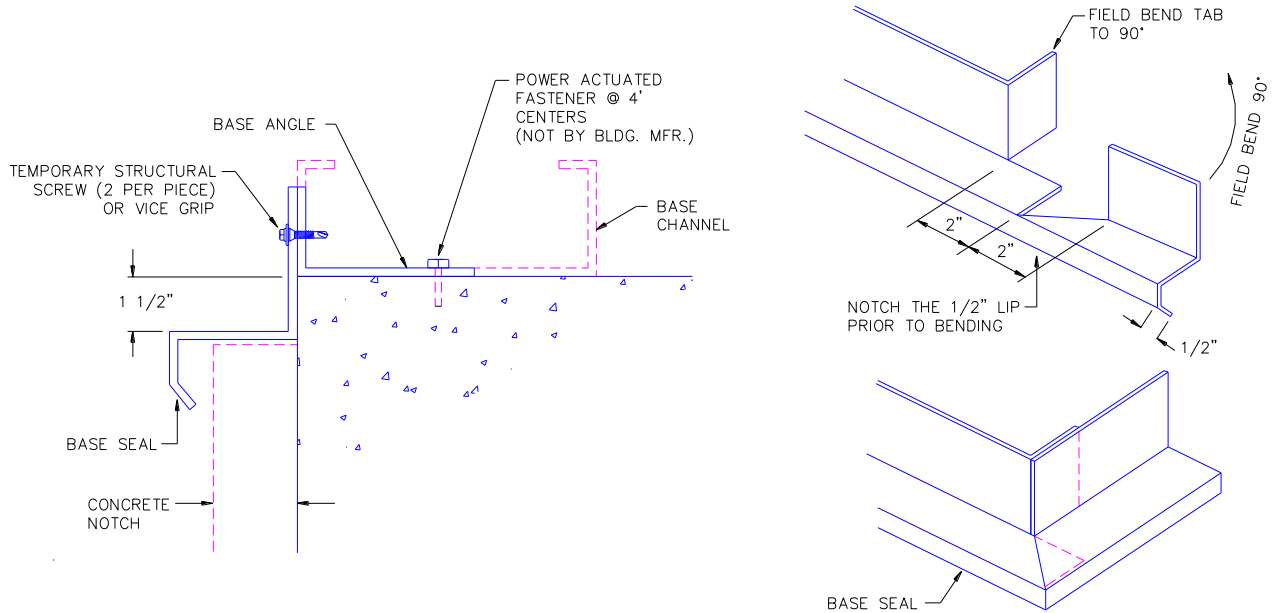

ILLUS. 5.13 BASE SEAL AT BOTTOM OF WALL PANEL

2. BASE ANGLE/SEAL

A one-piece base angle/seal will be butted end-to-end and mitered at the corners to give a finished appearance.

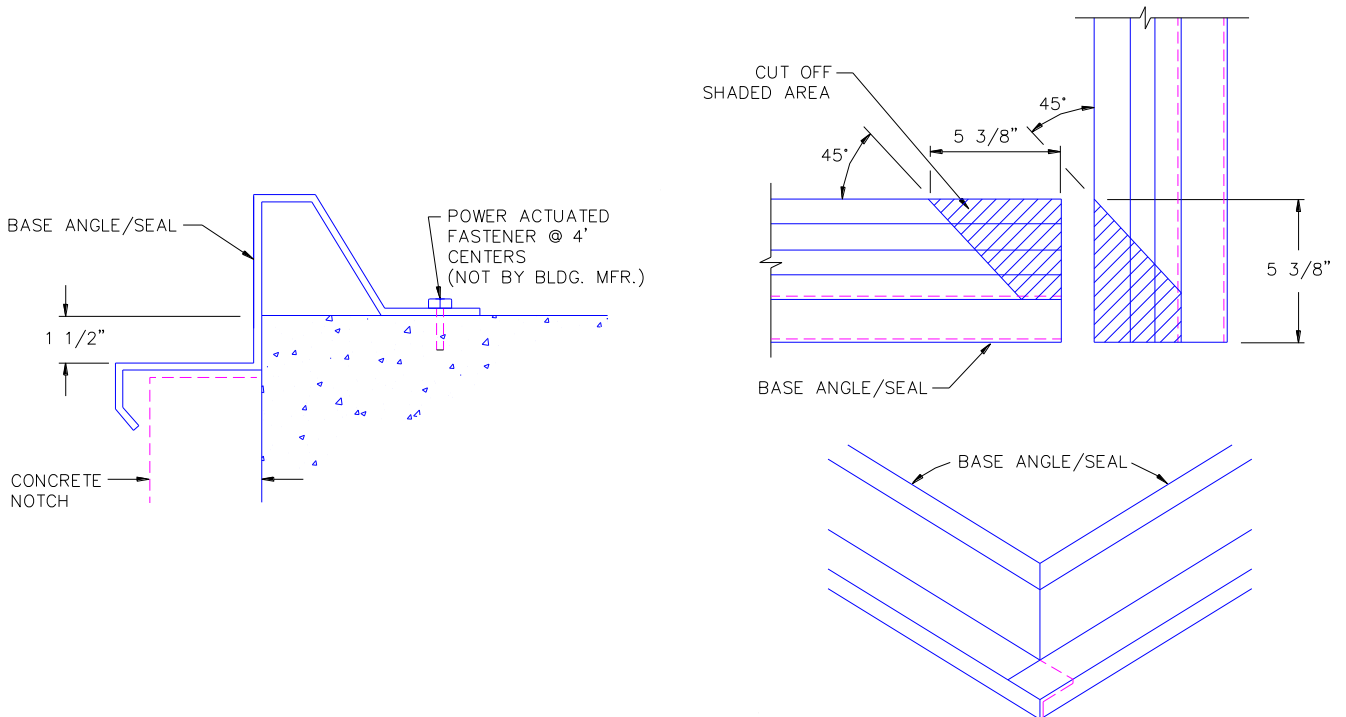

ILLUS. 5.14 BASE ANGLE/SEAL AT BOTTOM OF WALL PANEL

5.D CLOSURES AT BASE AND TOP OF PANEL

During the installation of wall panels, a line of inside foam closures will be placed at the base (see ILLUS. 5.15). An additional line of inside foam closures will be placed at the top of the panel on non-insulated buildings. (see ILLUS. 5.16).

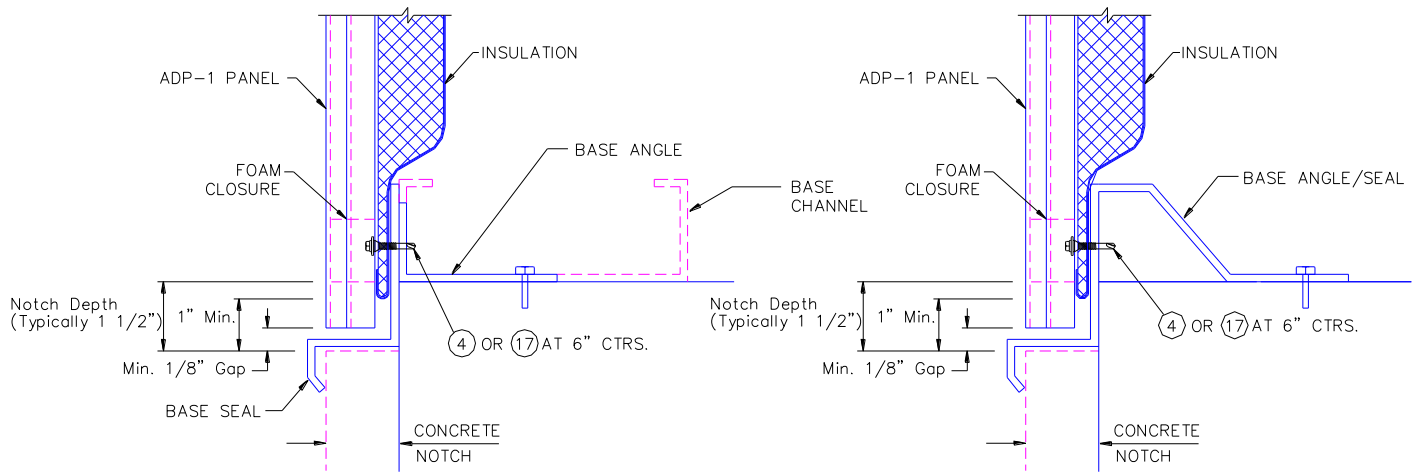

ILLUS. 5.15 FOAM CLOSURES AT BASE OF WALL

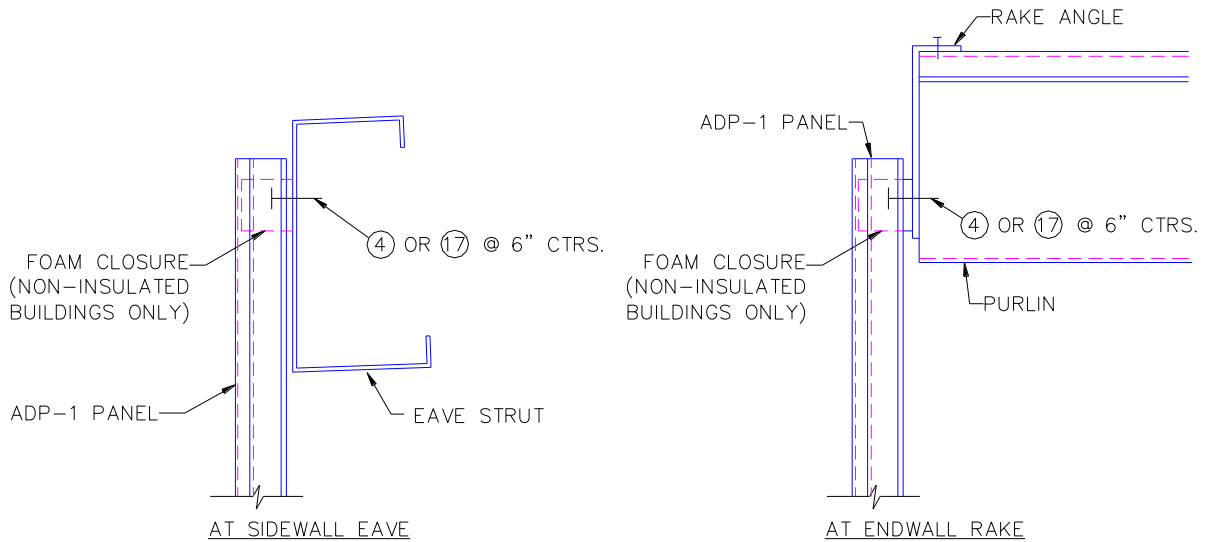

ILLUS. 5.16 FOAM CLOSURES AT TOP OF PANEL (NON-INSULATED BLDG. ONLY)

5.E WALL PANEL INSTALLATION

The following erection sequence contains the most pertinent aspects of wall covering installation. Refer to the job erection drawings at all times for specific information and details.

1. Cleaning metal chips from panels
2. Sheeting direction and preventing panel shortages
3. Locating first panel at corner
4. When panel endlap is required
5. Installing subsequent panels

1. CLEANING METAL CHIPS FROM PANELS

The act of installing self-drilling screws can produce hot metal chips on painted or bare panel surfaces that can literally melt into the panel coating causing them to become adhered to the panel. If these panels are not cleaned immediately, the potential for red rust to deface the panel is almost certain. Blow off loose shavings or use a soft cloth to gently wipe off shavings from panel.

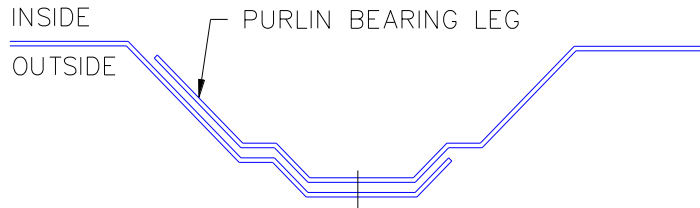

ILLUS. 5.17 PANEL SIDELAP

2. SHEETING DIRECTION AND PREVENTING PANEL SHORTAGES

When openings in a wall surface have been factory located and different length panels have been supplied, the following criteria was used to determine the quantities, unless noted otherwise on job erection drawings.

FRONT SIDEWALL

Start at left end of wall surface and proceed to the right until the other end is encountered.

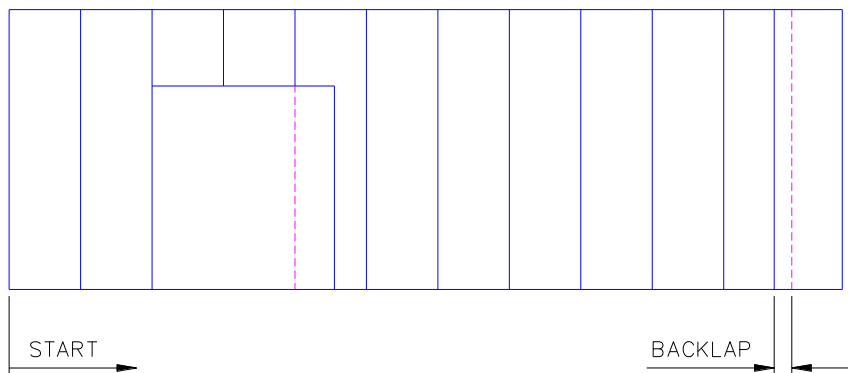

ILLUS. 5.18 FRONT SIDEWALL ELEVATION (VIEWED FROM OUTSIDE OF BUILDING)

BACK SIDEWALL

Start at right end of wall surface and proceed to the left until the other end is encountered.

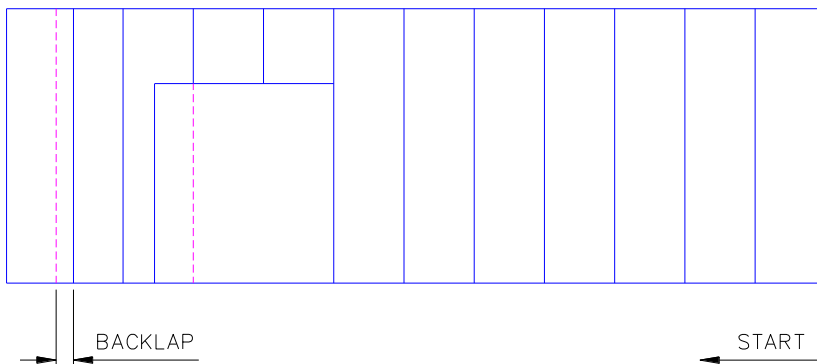

ILLUS. 5.19 BACK SIDEWALL ELEVATION (VIEWED FROM OUTSIDE OF BUILDING)

ENDWALL WITH PEAK

Start at peak and move outwards to each sidewall (see ILLUS. 5.20).

NOTE: ALL ENDWALL PANELS ARE SQUARE CUT ON BOTH ENDS. TOP ENDS OF PANELS ARE TO BE BEVELED WHEN ROOF PITCH EXCEEDS 1 1/2": 12.

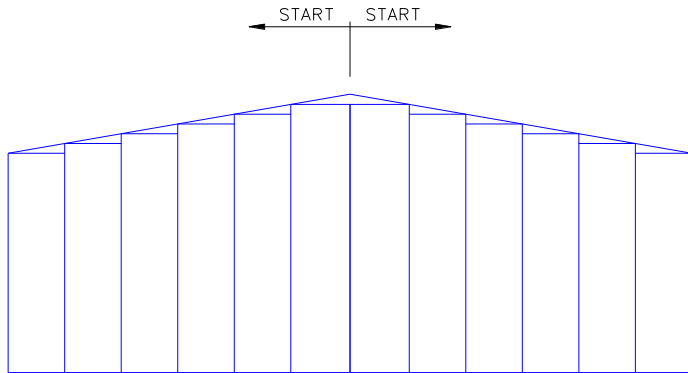

ILLUS. 5.20 ENDWALL WITH PEAK

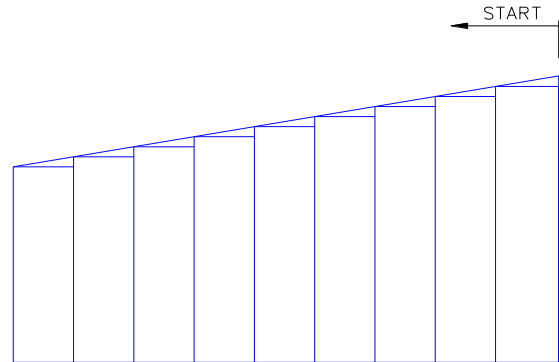

ILLUS. 5.21 ENDWALL WITHOUT PEAK

ENDWALL WITHOUT PEAK

Start at high eave then move towards low eave (see ILLUS. 5.21).

A shortage of full length wall panels can occur if sheets are not started exactly as indicated on the job erection drawings. Erection crews must be alert to this situation and follow plans exactly.

3. LOCATING FIRST PANEL AT CORNER

Once the first run of insulation has been applied, the first wall panel may be located at the corner of the building. The first panel may start AT THE CORNER or AWAY FROM THE CORNER by a "Start Dimension". Start dimensions will be noted on the wall elevations in the job erection drawings.

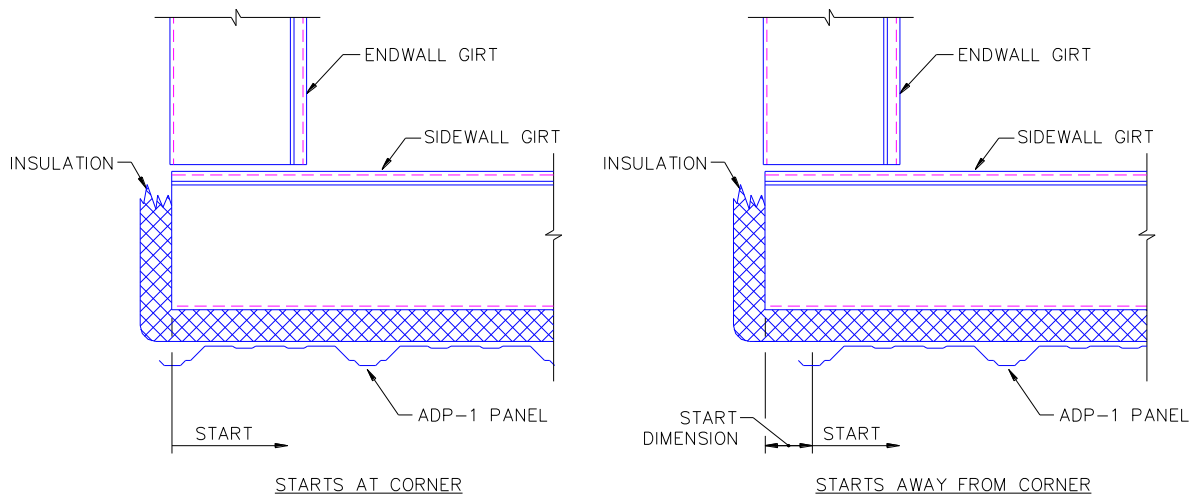

ILLUS. 5.22 LOCATING PANEL AT CORNER

After the first panel is positioned, squared and the closure is placed at base and top * of panel as shown in ILLUS. 5.15 and ILLUS. 5.16, install structural screws (see ILLUS. 4.5). Maintain a minimum 1/8" gap between the bottom edge of the wall panel and the base seal or concrete notch. When installing self-drilling screws drill shavings should be removed daily or humidity and rain will cause drill shavings to rust and stain the panel surface.

* Non-insulated buildings only

4. WHEN PANEL ENDLAP IS REQUIRED

When a wall panel endlap is required, the lap will be located at a girt.

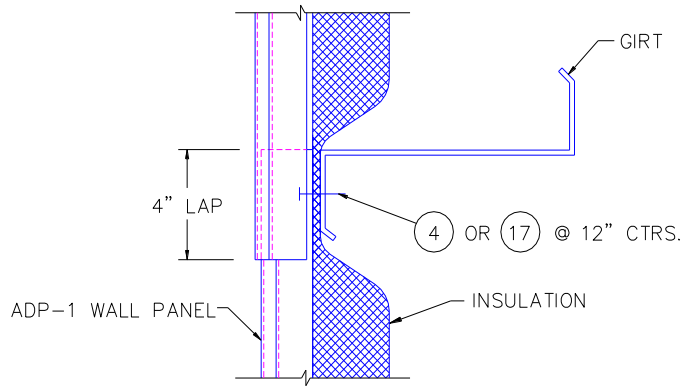

ILLUS. 5.23 WALL PANEL ENDLAP

5. INSTALLING SUBSEQUENT WALL PANELS

Place the next panel into position, checking the 3'-0" module, installing closure at base and installing structural screws (see ILLUS. 4.5).

Place stitch screws at 24" centers along sidelap (see ILLUS. 4.6). When installing self-drilling screws drill shavings should be removed daily or humidity and rain will cause drill shavings to rust and stain the panel surface.

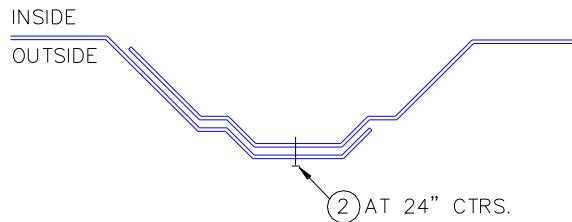

ILLUS. 5.24 ADP-1 PANEL SIDELAP

Hold panel module by checking the spacing either by marking the framework or pulling a tape measure periodically. If sheeting is getting out of module, correct the module as soon as possible.

5.F INSTALLING OUTSIDE CORNER TRIM

Outside corner trims that have allowances for varying wall panel START DIMENSIONS will be used to trim the building corners. When outside corner trim must be spliced, lap top trim over bottom trim by 2" and join with four (6) trim screws per lap.

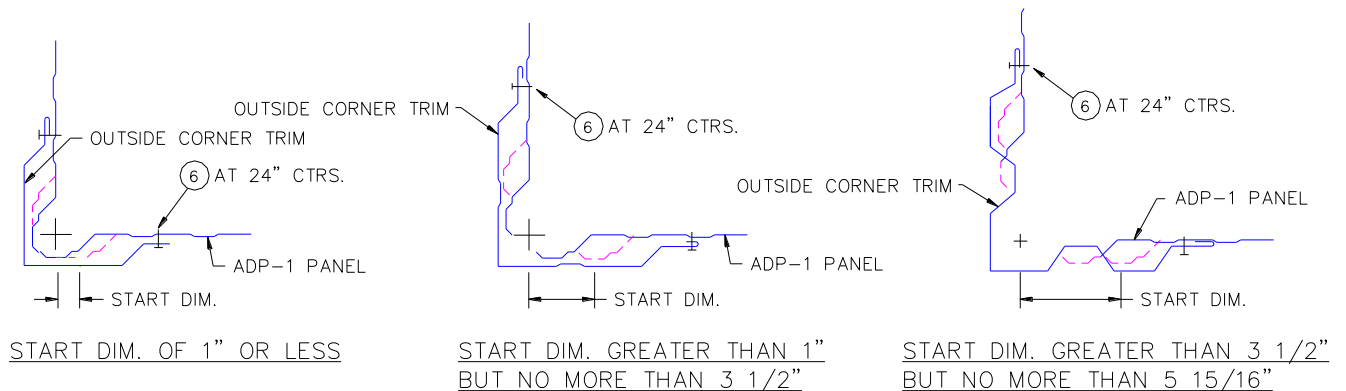

ILLUS. 5.25 OUTSIDE CORNER TRIMS

5.G INSTALLING INSIDE CORNER TRIM

Inside corner trims that have allowances for varying wall panel START DIMENSIONS will be used to trim the building corners. When inside corner trim must be spliced, lap top trim over bottom trim by 2" and join with four (6) trim screws per lap.

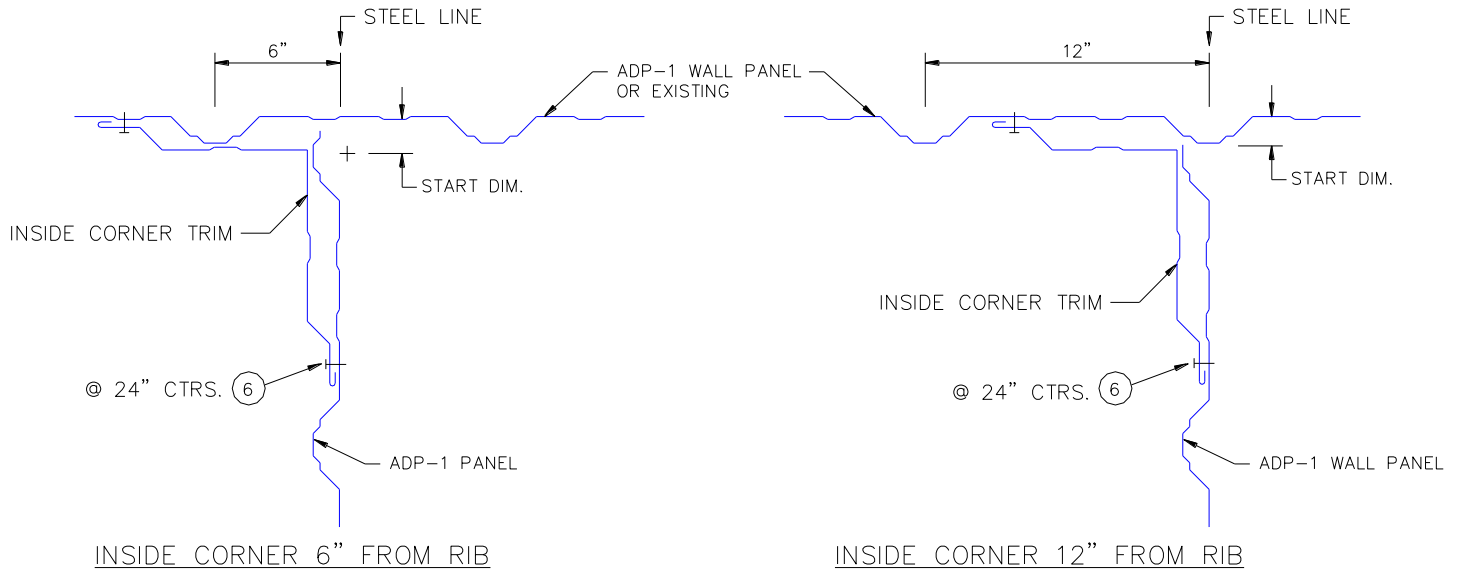

ILLUS. 5.26 INSIDE CORNER TRIM START DIM. OF 1" OR LESS

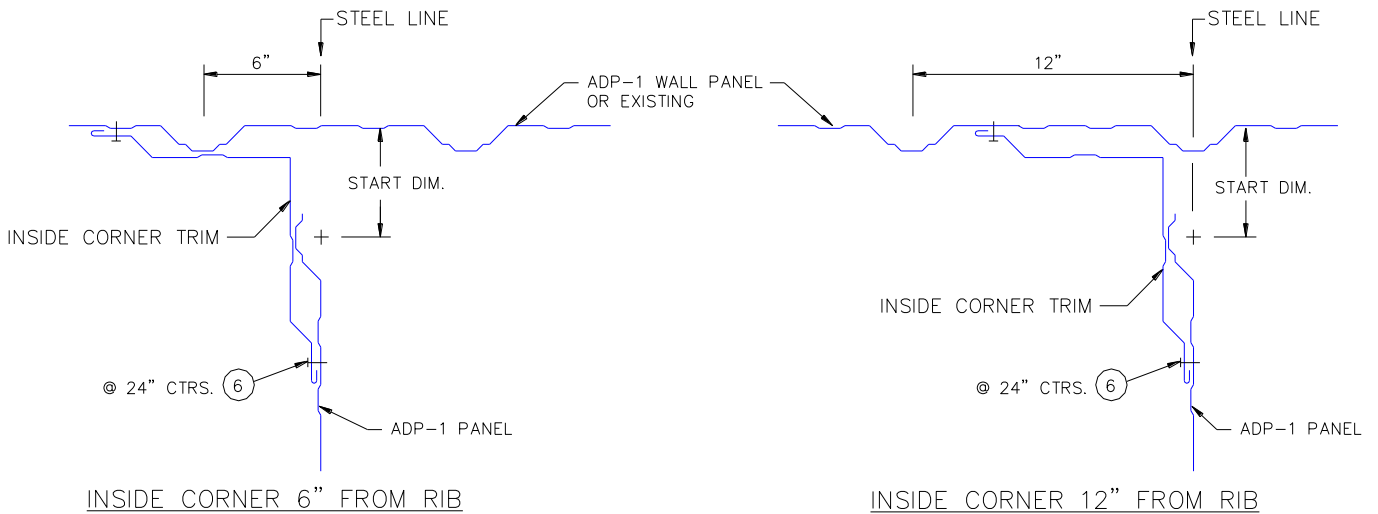

ILLUS. 5.27 INSIDE CORNER TRIM START DIM. OVER 1" BUT NO MORE THAN 4 1/2"

Depending on the profile of the adjacent wall panel, the lengths of the inside corner trim legs may vary. Information and details in the job erection drawings will govern.

When the high eave inside corner “ends” below the eave of a taller wall the high eave wall flashing should be extended outwards to close the upper end of the inside corner.

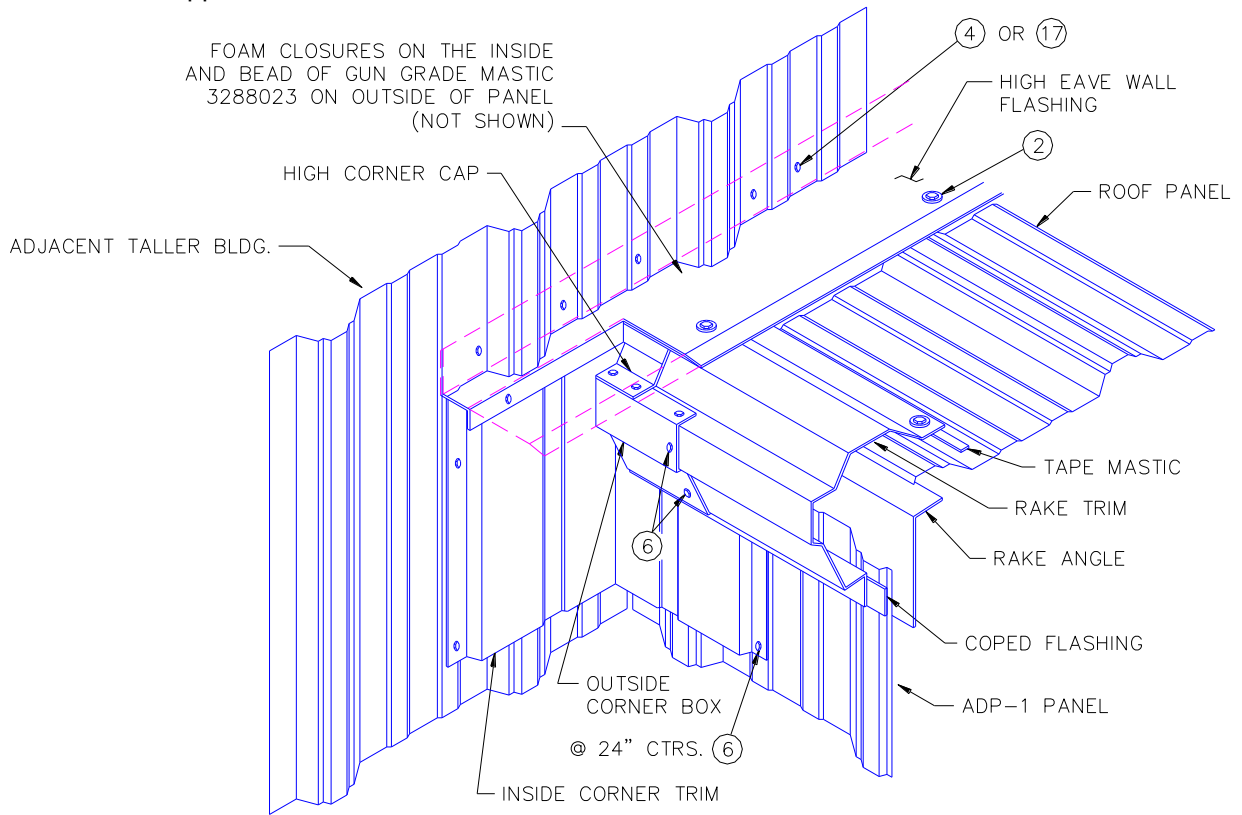

ILLUS. 5.28 HIGH EAVE INSIDE CORNER

5.H TRIM AT TOP OF WALL PANEL

When the roof perimeter trim is installed, insert coped flashings between trims and wall panels.

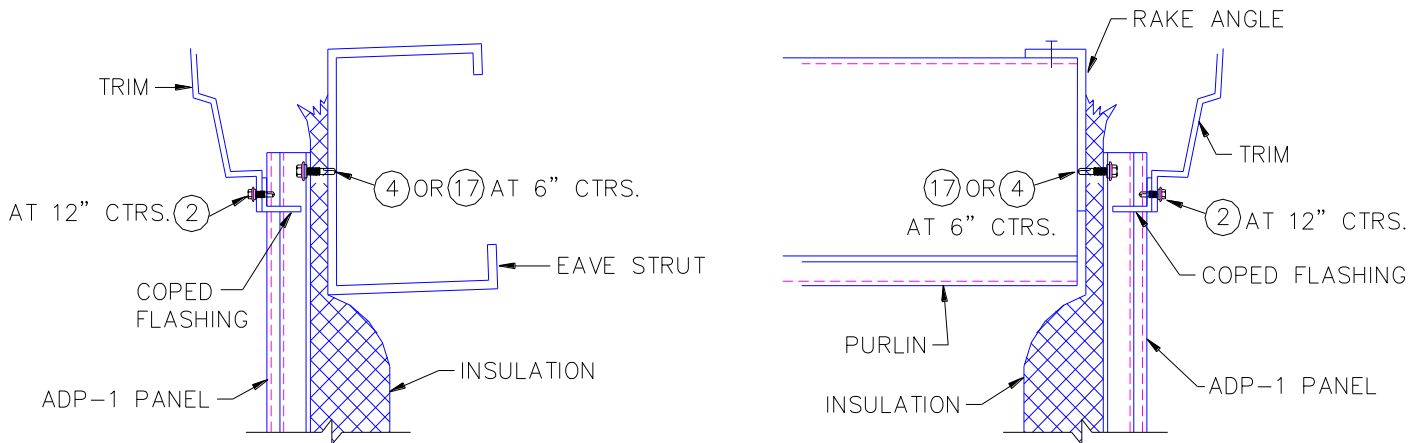

ILLUS. 5.29 ROOF PERIMETER TRIMS AT TOP OF WALL PANEL

6 ACCESSORIES

6.A FRAMED OPENINGS

Framed openings for overhead doors are installed as a part of the structural framing prior to sheeting the walls. Details and part numbers will be found on the job erection drawings. All frames ordered as field cut will require field cutting of girts and sheeting.

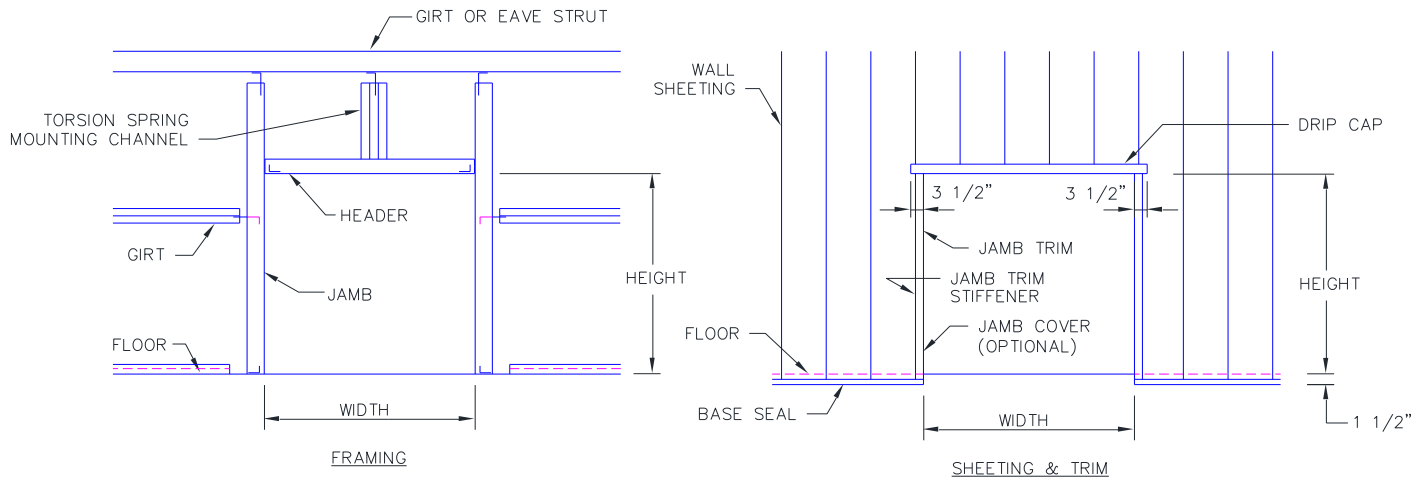

ILLUS. 6.1 FRAMED OPENINGS FOR OVERHEAD DOORS

1. (OPTIONAL) JAMB/HEADER COVERS

When optional jamb/header covers are required, install around opening prior to installing wall panels and trim (see ILLUS. 6.2 and ILLUS. 6.4).

2. CUTTING WALL PANELS

Field cut panels above opening as shown in ILLUS. 6.2 and field cut 3 1/2" long notch in wall panels in order to allow the drip cap to cover jamb trims at each side of opening (see ILLUS. 6.3). Maintain minimum 1/8" gap between the bottom edge of the panel and the drip cap.

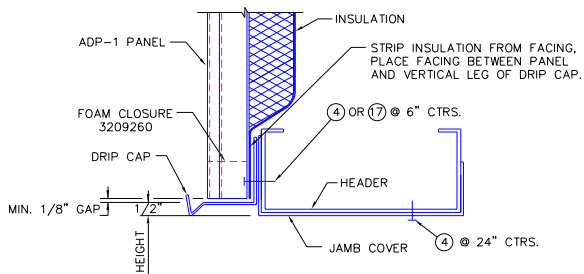

ILLUS. 6.2 PANELS AT HEADER

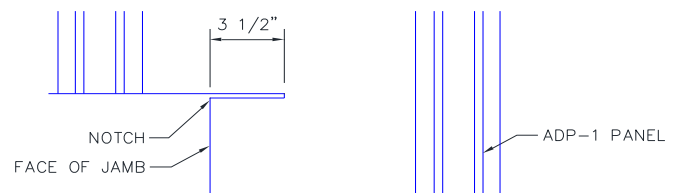

ILLUS. 6.3 NOTCH PANELS FOR DRIP CAP

3. INSTALLING DRIP CAP

Position drip cap as shown above, install foam closures along header and secure with screws (see ILLUS. 4.5). When more than one drip cap piece is used, field notch and lap ends 2".

4. INSTALLING TRIMS ALONG JAMBS

Position the jamb trim stiffener over the wall panel and insulation facing as shown in ILLUS. 6.4 and attach to the jamb with structural screws. Attach jamb trim to jamb with structural screws and to the jamb trim stiffener with trim screws. Lap jamb trim 2" when required.

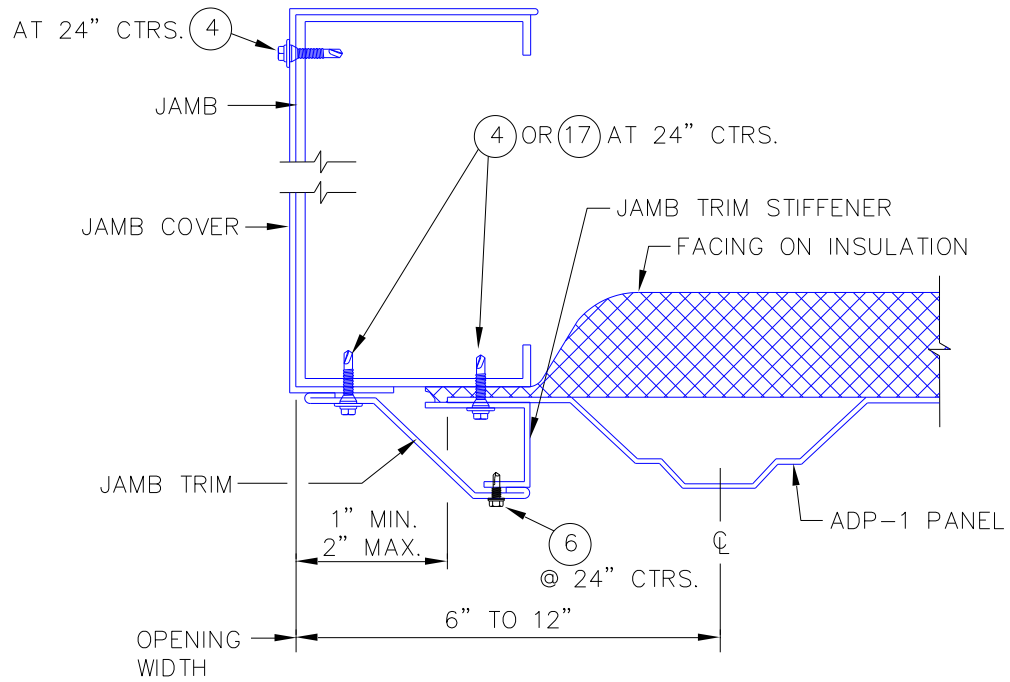

ILLUS. 6.4 TRIMS AT SIDES OF FRAMED OPENING

6.B FRAMED OPENINGS WITH SILL

Framed openings with sills are installed as a part of the structural framing prior to sheeting the walls. Details and part numbers will be found on the job erection drawings. Frames will require field cutting of girts.

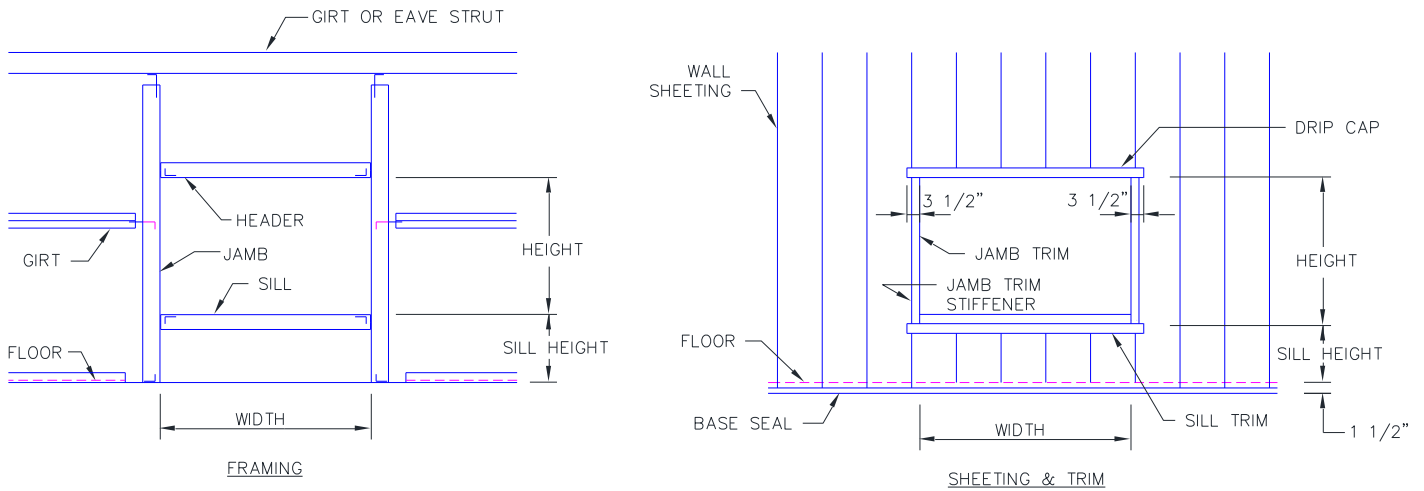

ILLUS. 6.5 FRAMED OPENINGS WITH SILL

1. CUTTING WALL PANELS AT HEADER

Field cut panels above opening as shown in ILLUS. 6.6 and field cut 3 1/2" long notch in wall panels in order to allow the drip cap to cover jamb trims at each side of opening (see ILLUS. 6.7). Maintain minimum 1/8" gap between the bottom edge of the panel and the drip cap.

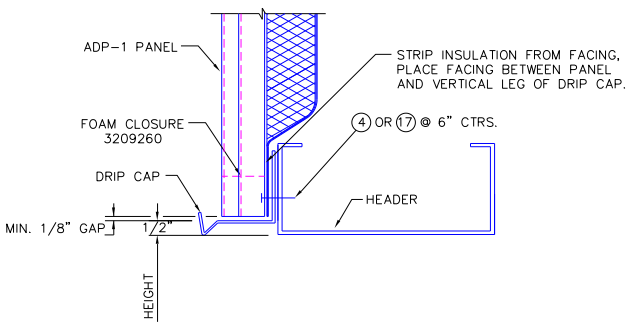

ILLUS. 6.6 PANELS AT HEADER

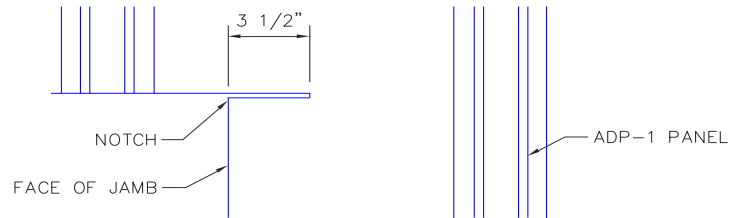

ILLUS. 6.7 NOTCH PANELS FOR DRIP CAP

2. INSTALLING DRIP CAP

Position drip cap as shown (above) install foam closures along header and secure with screws (see ILLUS. 6.6) When more than one drip cap piece is used, field notch and lap ends 2".

3. CUTTING WALL PANELS AT SILL

Field cut panels below opening as shown in ILLUS. 6.8 and field cut 3" long notch in wall panels in order to allow the sill trim to extend beyond the jamb trim (see ILLUS. 6.9).

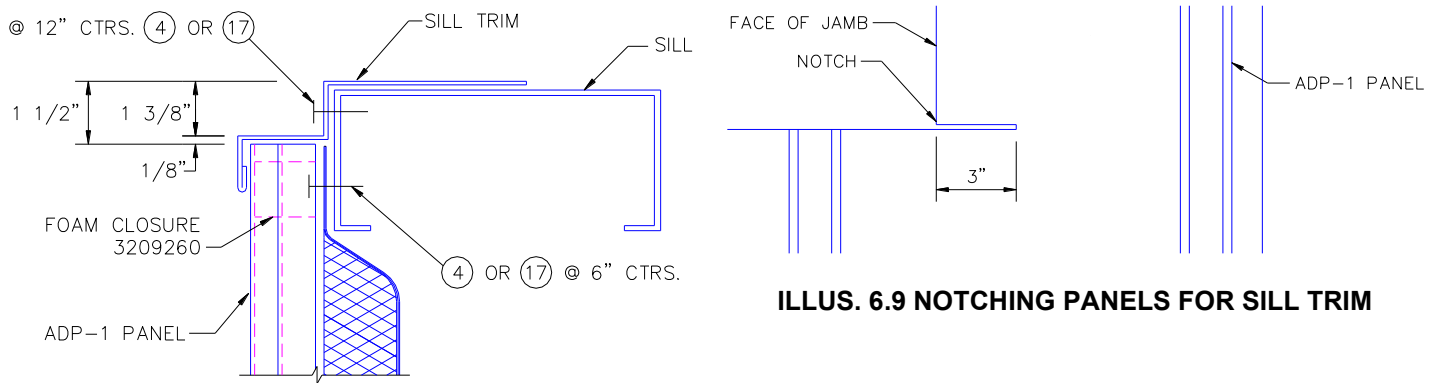

ILLUS. 6.9 NOTCHING PANELS FOR SILL TRIM

ILLUS. 6.8 PANELS AT SILL

4. INSTALLING SILL TRIM

Position sill trim as shown above, extending 3" beyond the opening width at each side. Install foam closures along sill and secure with screws (see ILLUS. 4.5). Sill trim will be attached to the sill with screws at 12" centers see (above).

5. INSTALLING JAMB TRIM

Position the jamb trim stiffener over the wall panel and insulation facing as shown in ILLUS. 6.10 and attach to the jamb with structural screws. Attach jamb trim to jamb with structural screws and to the jamb trim stiffener with trim screws. Trims along the jamb will extend from the notch in the sill trim to the underside of the drip cap.

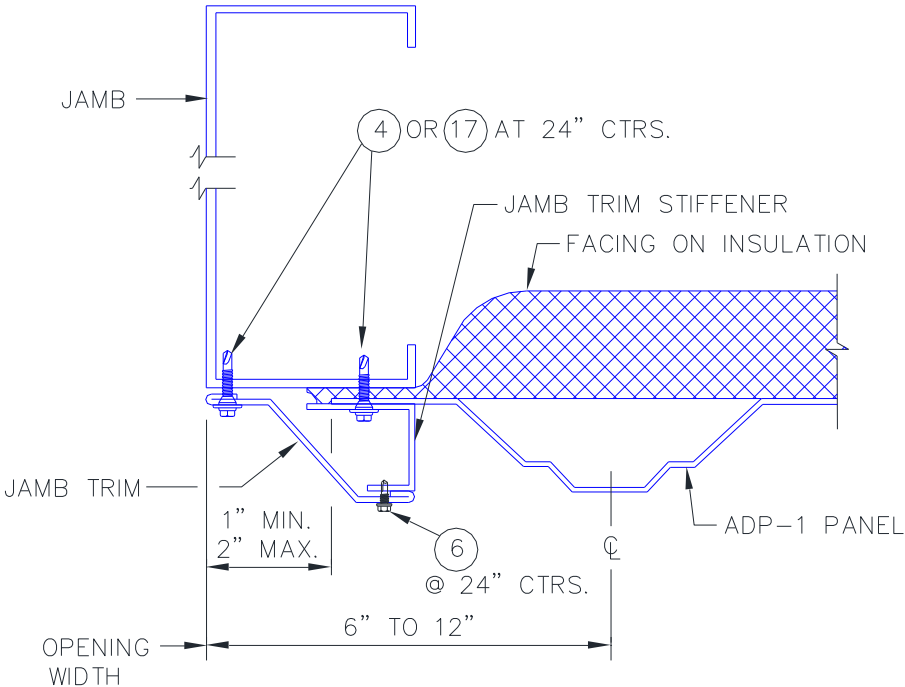

ILLUS. 6.10 TRIMS AT SIDES OF FRAMED OPENING

6.C PREASSEMBLED WALK DOOR

Install the preassembled walk door and frame prior to the wall panels.

See installation instructions provided with door. The illustrations below are cross sections of completed doors with trim components and screws identified.

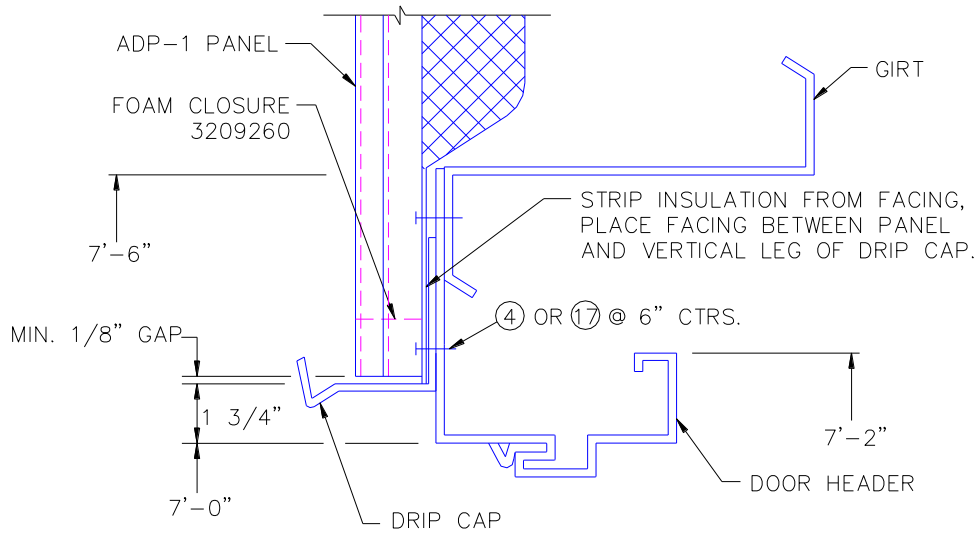

ILLUS. 6.11 SECTION AT HEADER

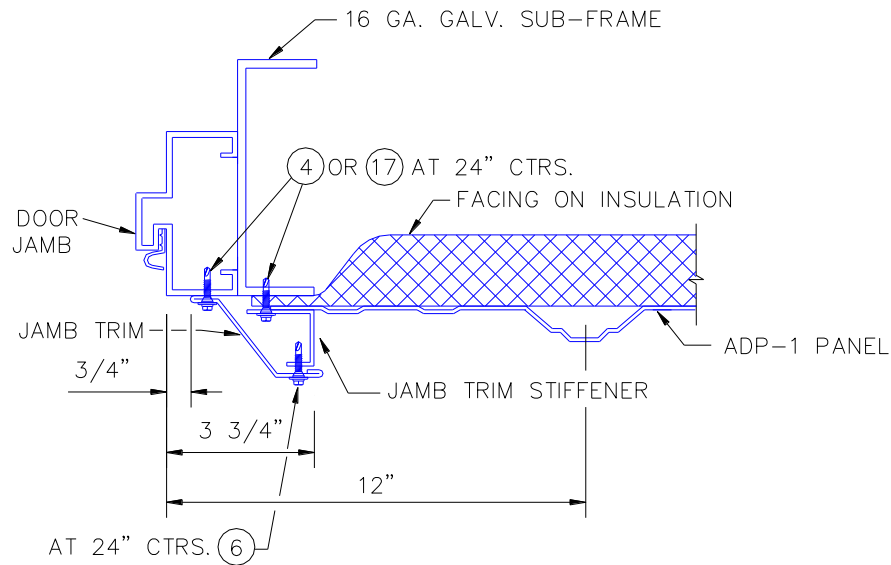

ILLUS. 6.12 SECTIONS AT JAMBS

Field cut wall sheeting for walk door opening and notch panels for drip cap (see ILLUS. 6.3). Install drip cap, jamb trim stiffener and jamb trim as shown and described (see ILLUS. 6.2 and ILLUS. 6.4). Maintain minimum 1/8" gap between the bottom edge of the panel and the drip cap.

DOMINION KNOCK-DOWN WALK DOOR

Assemble the door frame, see installation instructions provided with door. Secure the walk door frame to a girt line by using the jamb extensions.

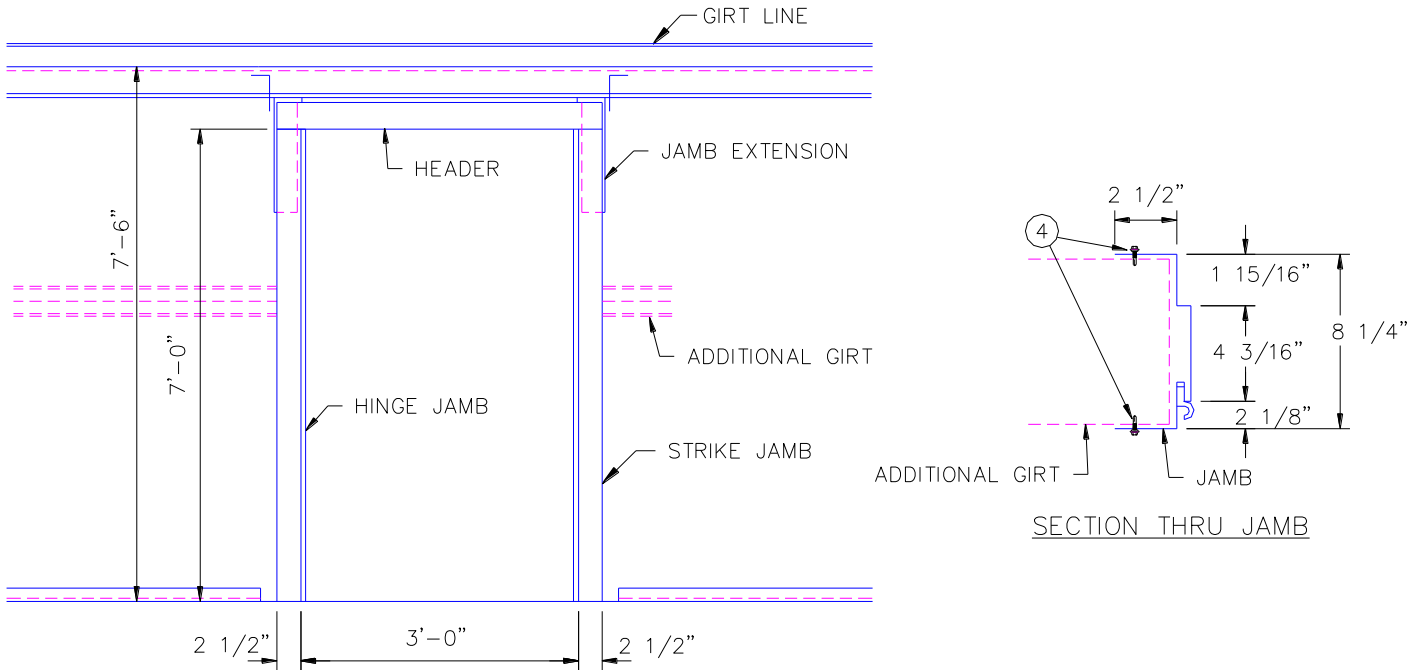

ILLUS. 6.13 KNOCK-DOWN WALK DOOR FRAME

The illustrations below are cross sections of completed doors with trim components and screws identified.

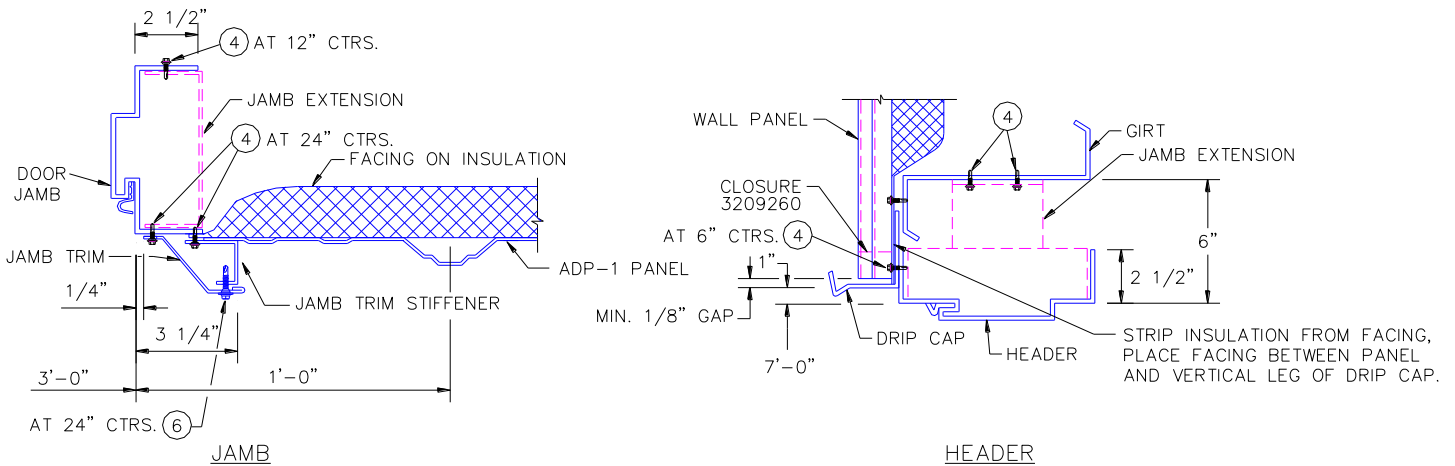

ILLUS. 6.14 SECTIONS AT JAMBS AND HEADER

Field cut wall sheeting for walk door opening and notch panels for drip cap (see ILLUS. 6.3). Install drip cap, jamb trim stiffener and jamb trim as shown and described (see ILLUS. 6.2 and ILLUS. 6.4). Maintain minimum 1/8" gap between the bottom edge of the panel and the drip cap.

6.D WALK DOOR ROUGH FRAME (BELOW 7'-6" GIRT ELEV.)

Walk door framed openings are installed as a part of the structural framing prior to sheeting the walls. All frames will require field cutting of the sheeting. All part numbers are listed in the Framed Openings Parts Table that can be found on the erection drawings.

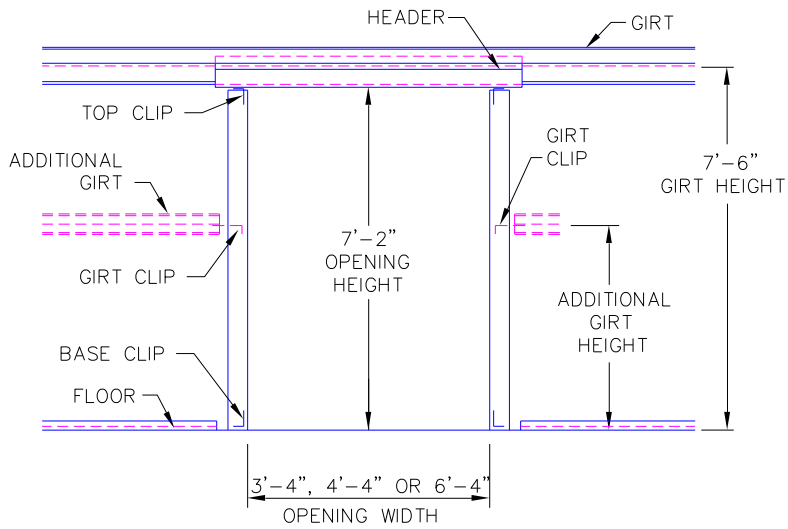

ILLUS. 6.15 WALK DOOR ROUGH FRAME

1. LOCATING FRAMED OPENING

Locate the door so that the jamb face falls 10" from a major panel rib. When the location has been determined, set anchor bolts to dimensions shown in ILLUS. 6.16.

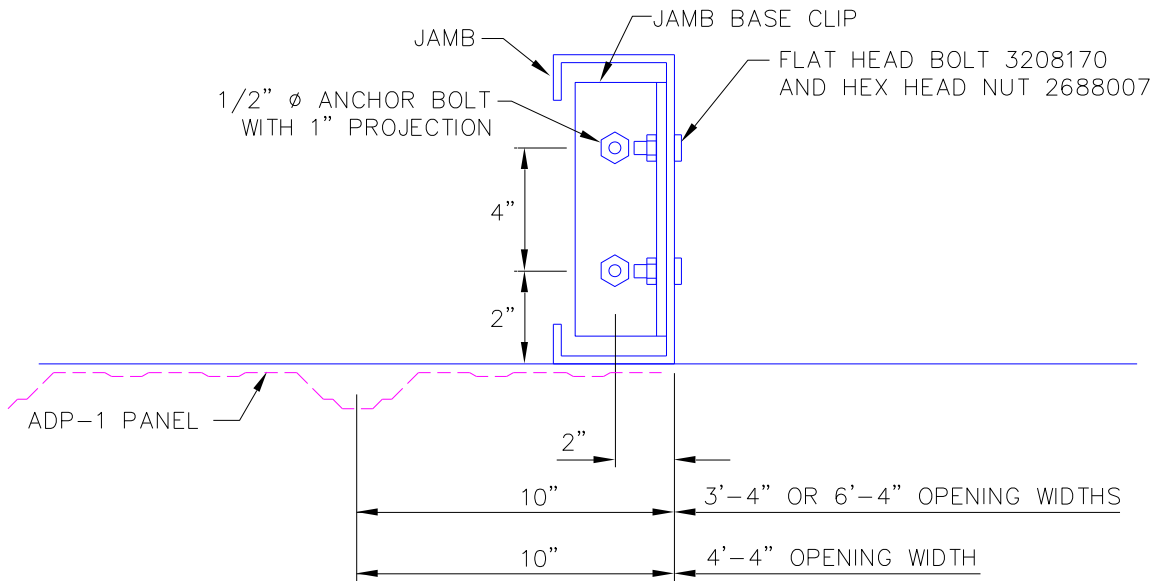

ILLUS. 6.16 DOOR JAMB AND ANCHOR BOLT SETTINGS

2. LOCATING HEADER

Locate header as shown in ILLUS. 6.17 and attach header to girt with (2) structural screws.

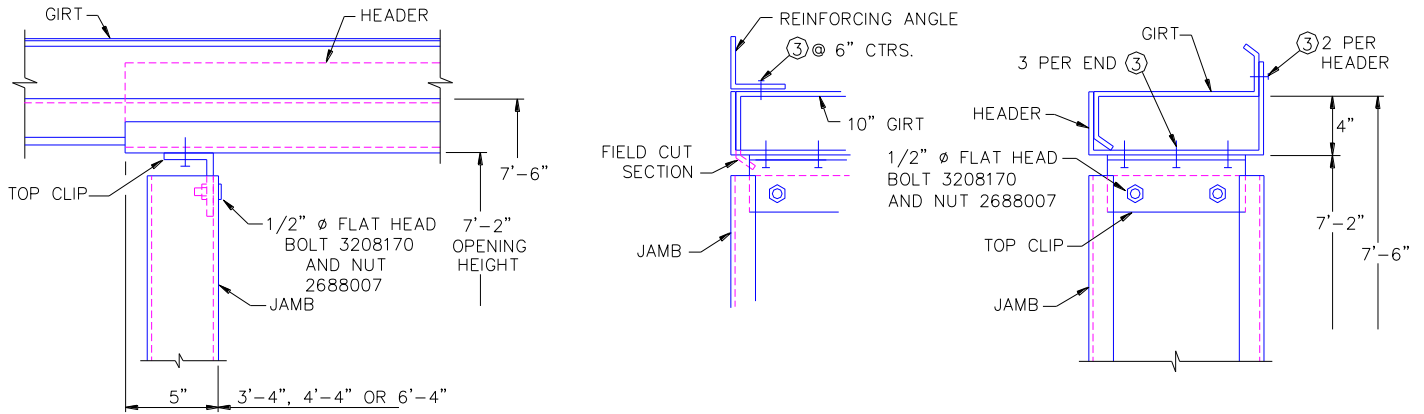

ILLUS. 6.17 HEADER AND JAMB CONNECTION TO GIRTS

3. ATTACH CLIP TO JAMB TOP

Place top clip on inside of jamb and bolt with 1/2" x 1" flat head bolts and nuts (see ILLUS. 6.17).

4. SET JAMB

Set base clip over anchor bolts and tighten nuts finger tight. Place jamb against clip and bolt with 1/2" x 1" flat head bolts and nuts (see ILLUS. 6.16).

5. ATTACH JAMB AT TOP

After checking for plumb and square, attach jamb top clip to header with structural screws (3) per end (see ILLUS. 6.17).

6. ATTACHING REINFORCING ANGLE

On buildings with 10" deep girts, whose stiffening lip has been field cut off, a reinforcing angle will be centered above the opening and attached with structural screws at 6" centers (see ILLUS. 6.17).

7. ATTACHING ADDITIONAL GIRTS TO JAMB

Attach additional girts (below 7'-6" elevation) to jamb with a clip and 1/2" x 1" flat head bolts and nuts. Use 1/2" x 1 1/2" hvhx head bolts and nuts to attach clips to girts (see ILLUS. 6.18).

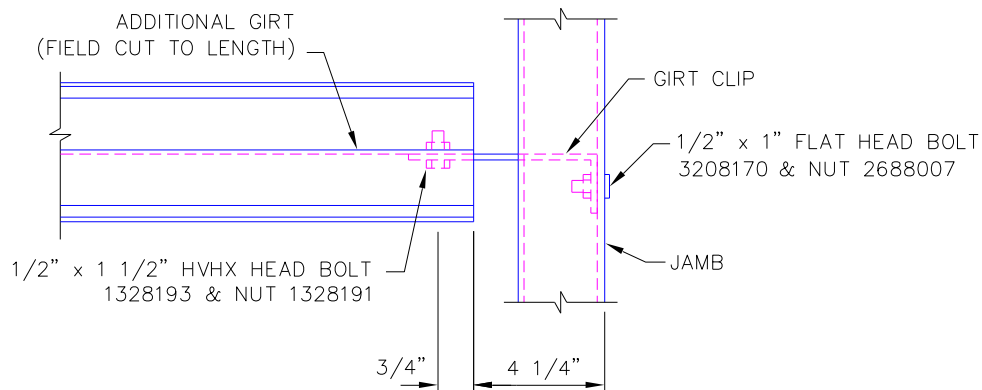

ILLUS. 6.18 ATTACHING ADDITIONAL GIRT LINE

8. **CUTTING WALL PANELS**

Field cut panels above opening as shown in ILLUS. 6.19 and field cut 3 1/2" long notch in wall panels in order to allow the drip cap to cover jamb trims at each side of opening (see ILLUS. 6.20). Maintain minimum 1/8" gap between the bottom edge of the panel and the drip cap.

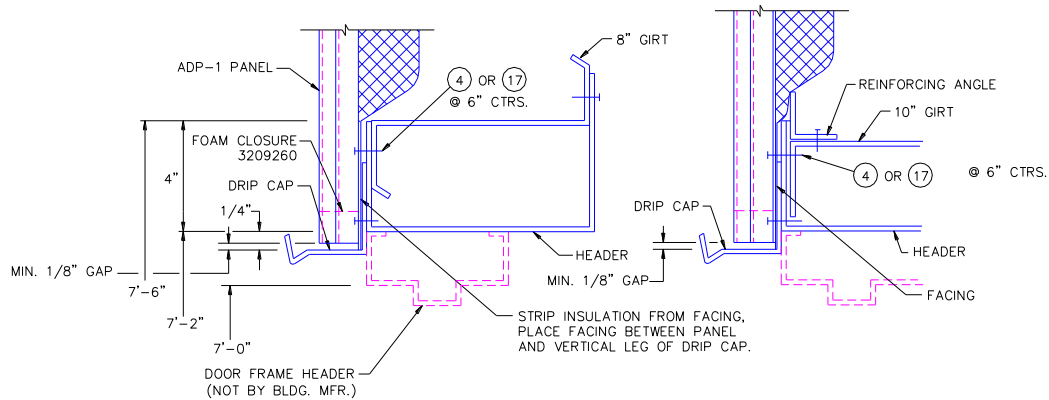

ILLUS. 6.19 PANELS AT HEADER

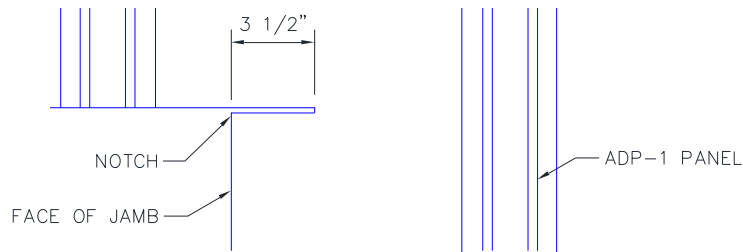

ILLUS. 6.20 NOTCH PANELS FOR DRIP CAP

INSTALLING DRIP CAP

Position drip cap as shown in ILLUS. 6.19 and install foam closures along header securing with screws (see ILLUS. 4.5).

INSTALLING TRIMS ALONG JAMBS

Position the jamb trim stiffener over the wall panel and insulation facing as shown in ILLUS. 6.21 and attach to the jamb with structural screws. Attach jamb trim to jamb with structural screws and to the jamb trim stiffener with trim screws. Trims along the jamb will extend from the notch in the concrete to the underside of the drip cap.

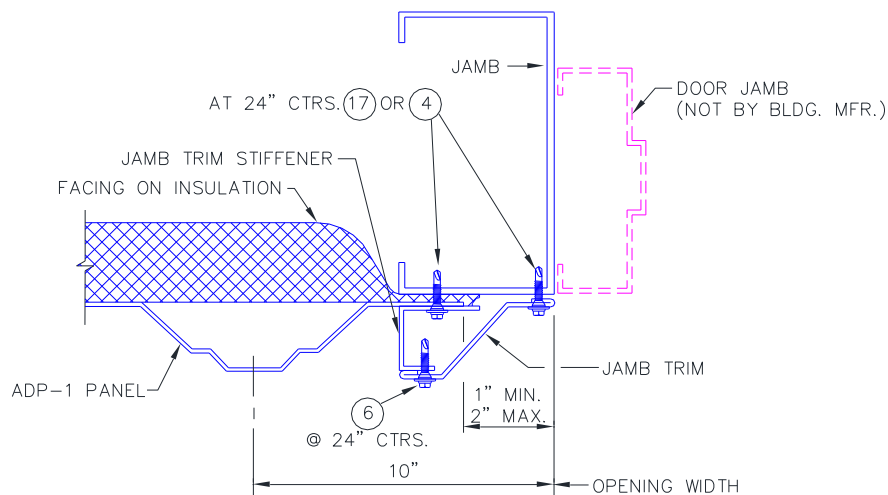

ILLUS. 6.21 TRIMS AT SIDE OF OPENING

6.E PREASSEMBLED WINDOW

Install the preassembled window/frame prior to the wall panels. See installation instructions provided with window. The illustrations below are cross sections of horizontal slide windows. There are some dimensional differences between PDL and DOMINION windows which are noted below.

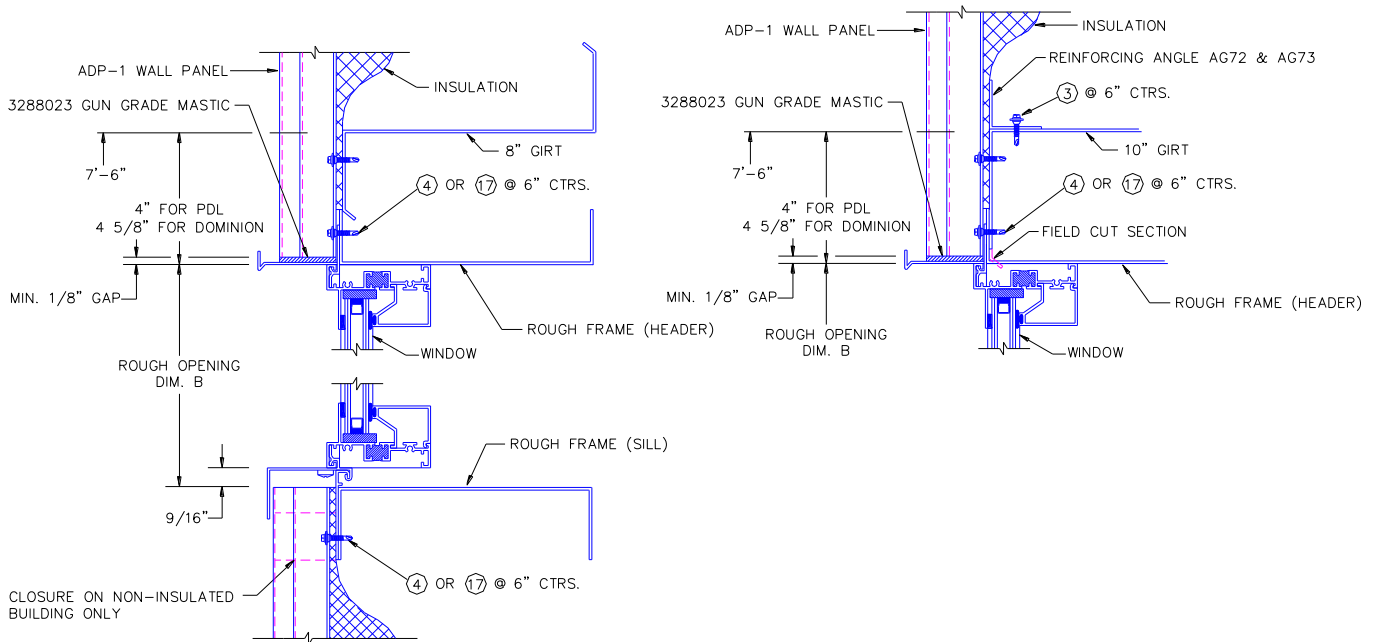

ILLUS. 6.22 SECTION THRU HEADER AND SILL (8" AND 10" GIRTS)

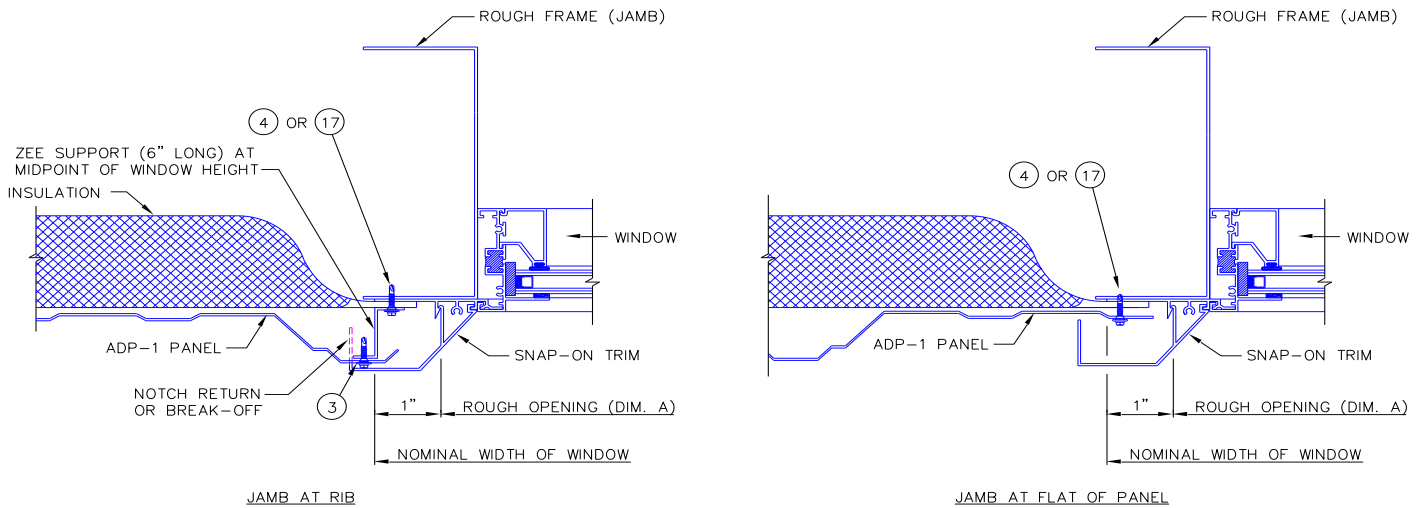

ILLUS. 6.23 SECTION THRU JAMB

See table at right for minimum field cut openings in wall sheeting.

MINIMUM ROUGH OPENING		
Nominal Size	Dim. A	Dim. B
3030	32 1/4"	34 3/8"
4030	44 1/4"	34 3/8"
5030	56 1/4"	34 3/8"
6030	68 1/4"	34 3/8"
4040	44 1/4"	46 3/8"

6.F ROUGH FRAME WITH SILL (BELOW 7'-6" GIRT ELEV.)

A rough frame with sill is installed as a part of the structural framing prior to sheeting the walls. All frames will require field cutting of the sheeting. All part numbers are listed in the Framed Openings Parts Table that can be found on the erection drawings.

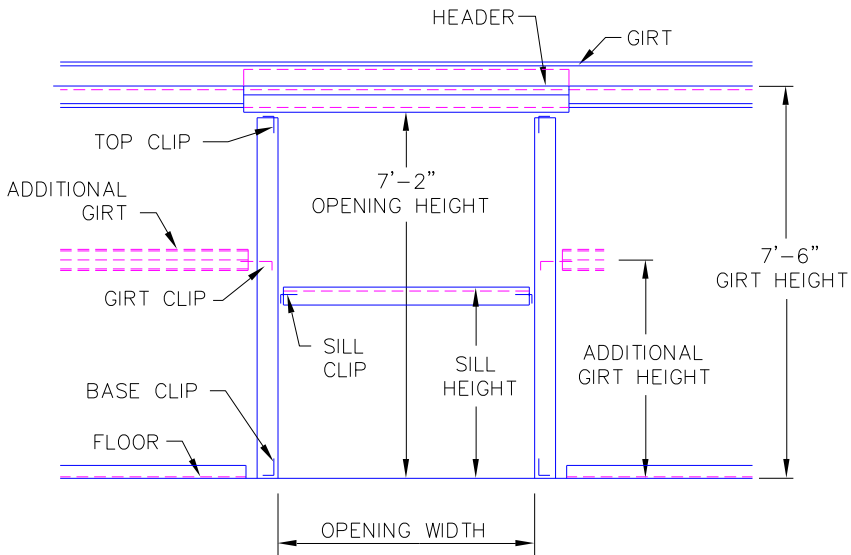

ILLUS. 6.24 FRAMED OPENING WITH SILL

1. LOCATING FRAMED OPENING

Locate the opening so that the jamb face falls between 6" to 12" from a major panel rib. When the location has been determined, set anchor bolts to dimensions shown in ILLUS. 6.25.

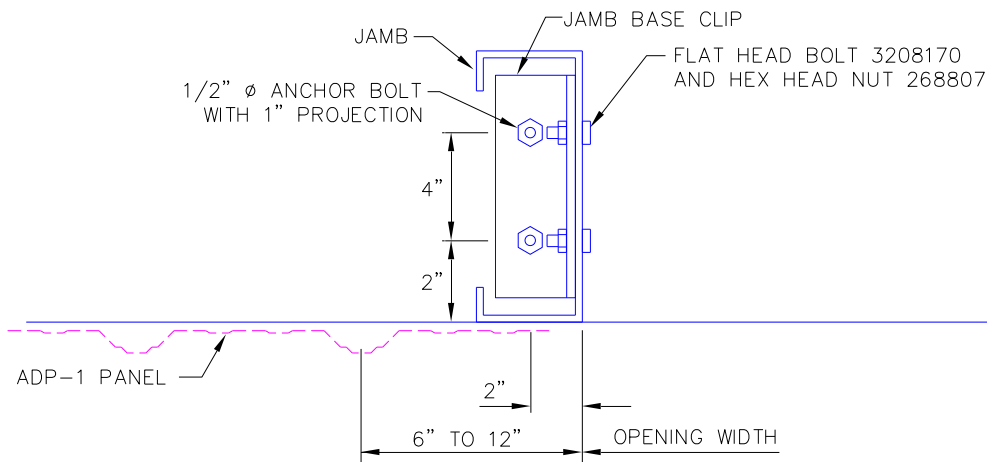

ILLUS. 6.25 DOOR JAMB AND ANCHOR BOLT SETTINGS

2. LOCATING HEADER

Locate header as shown in ILLUS. 6.26 and attach header to girt with (2) structural screws.

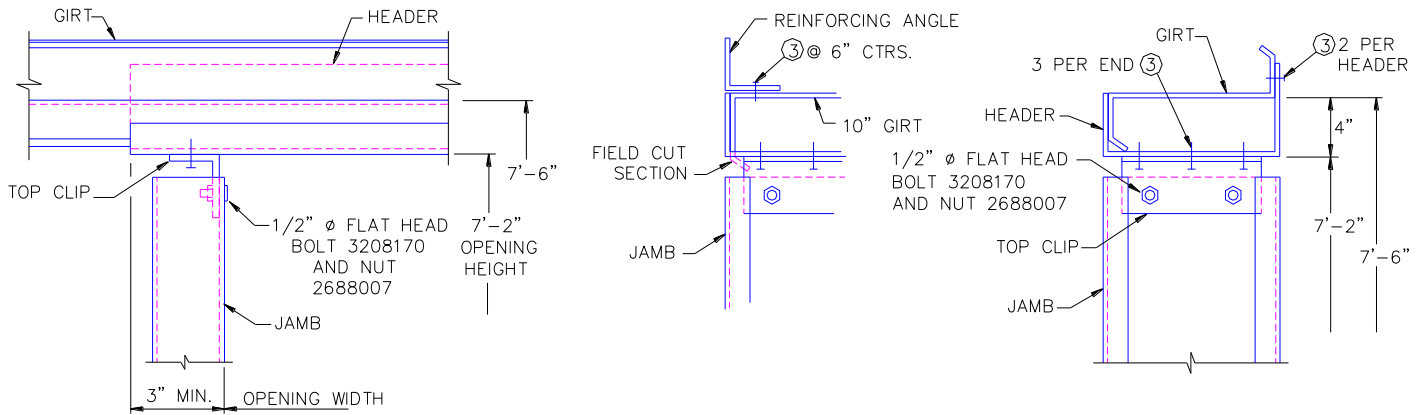

ILLUS. 6.26 HEADER AND JAMB CONNECTIONS TO GIRTS

3. ATTACH CLIP TO JAMB TOP

Place top clip on inside of jamb and bolt with 1/2" x 1" flat head bolts and nuts (see ILLUS. 6.26).

4. SET JAMB

Set base clip over anchor bolts and tighten nuts finger tight. Place jamb against clip and bolt with 1/2" x 1" flat head bolts and nuts (see ILLUS. 6.25).

5. ATTACH JAMB AT TOP

After checking for plumb and square, attach jamb top clip to header with structural screws (3) per end (see ILLUS. 6.26).

6. ATTACHING REINFORCING ANGLE

On buildings with 10" deep girts, whose stiffening lip has been field cut off, a reinforcing angle will be centered above the opening and attached with structural screws at 6" centers (see ILLUS. 6.26).

7. ATTACHING ADDITIONAL GIRTS TO JAMB

Attach additional girts, below 7'-6" elevation, to jamb with a clip and 1/2" x 1" flat head bolts and nuts. Use 1/2" x 1 1/2" hvhx head bolts and nuts to attach clips to girts (see ILLUS. 6.27).

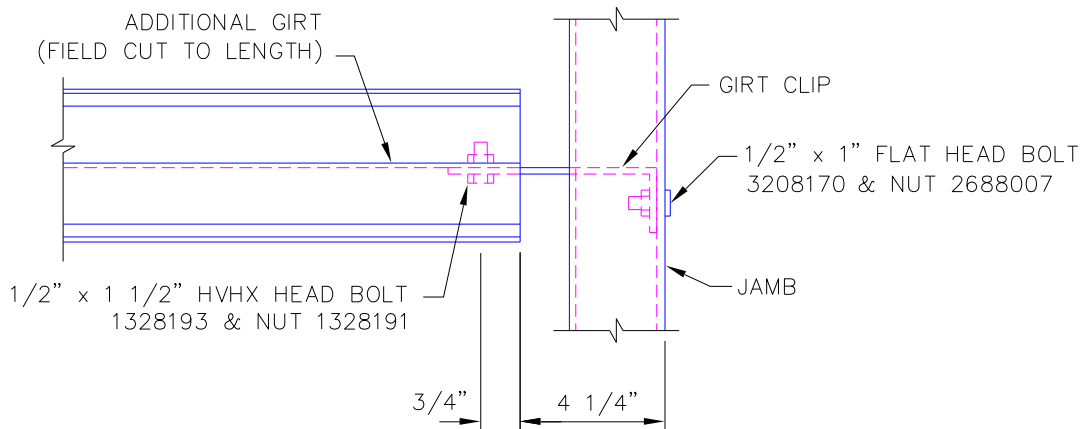

ILLUS. 6.27 ATTACHING ADDITIONAL GIRTS TO JAMB

8. **INSTALLING SILL**

See job erection drawings for sill part numbers. Attach sill clip to each end of sill with 1/2" x 1" flat head bolts and nuts. Use 1/2" x 1 1/2" hvhx head bolts and nuts to attach clips in sill to the jambs.

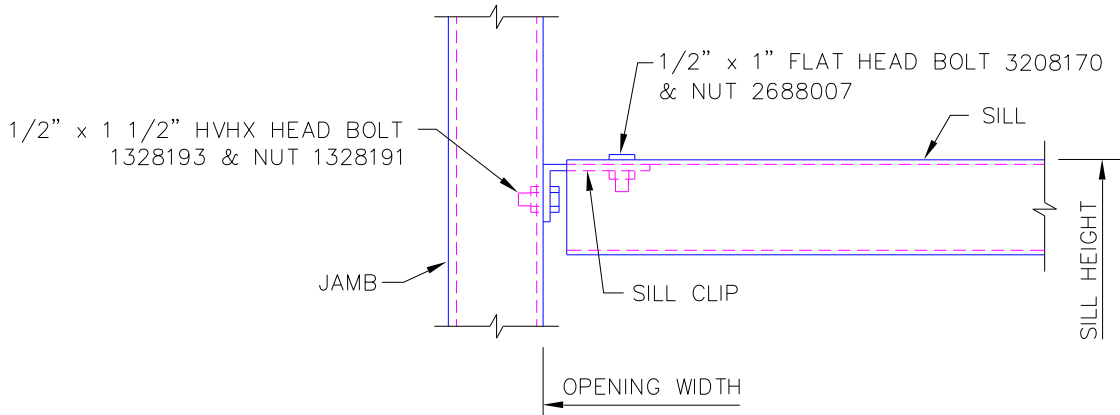

ILLUS. 6.28 ATTACHING SILL TO JAMB

9. **CHECK PLUMB AND SQUARE**

Check plumb and square of frame and tighten all bolts.

CUTTING WALL PANELS

Field cut panels above opening as shown in ILLUS. 6.29 and field cut 3 1/2" long notch in wall panels in order to allow the drip cap to cover jamb trims at each side of opening (see ILLUS. 6.30).

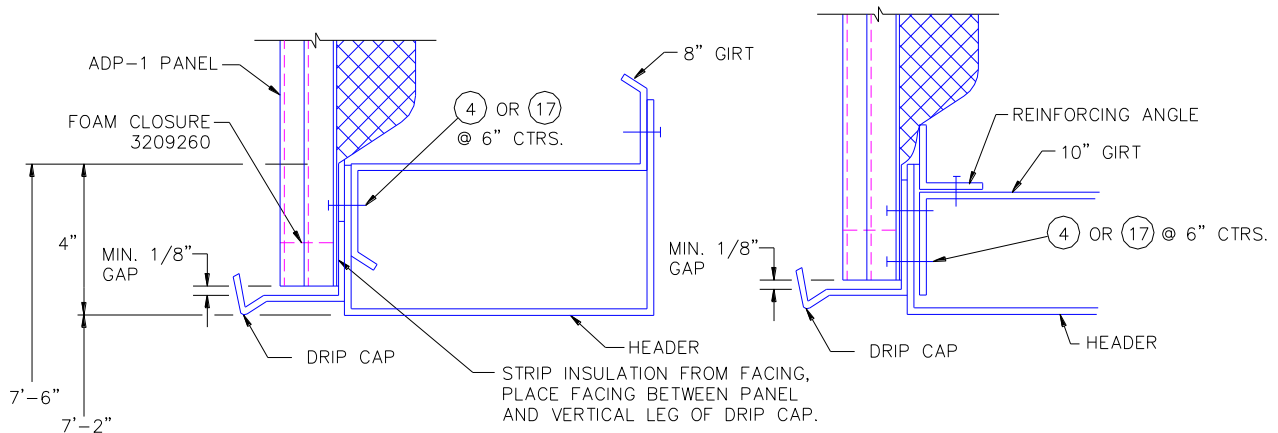

ILLUS. 6.29 PANELS AT HEADER

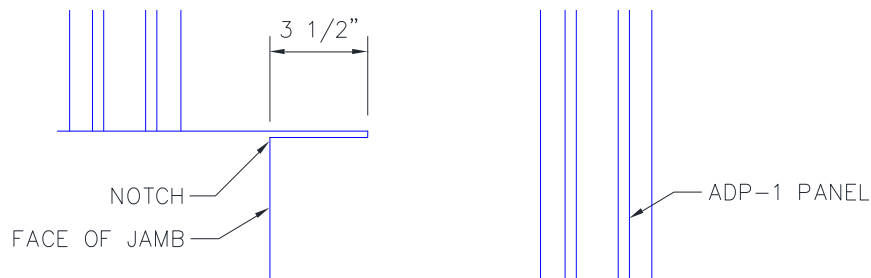

ILLUS. 6.30 NOTCH PANELS FOR DRIP CAP

10. INSTALLING DRIP CAP

Position drip cap as shown in ILLUS. 6.29 and install foam closures along header securing with screws as shown in ILLUS. 4.5.

11. CUTTING WALL PANELS AT SILL

Field cut panels below opening as shown in ILLUS. 6.31 and field cut 3" long notch in wall panels in order to allow the sill trim to extend beyond the jamb trim (see ILLUS. 6.32).

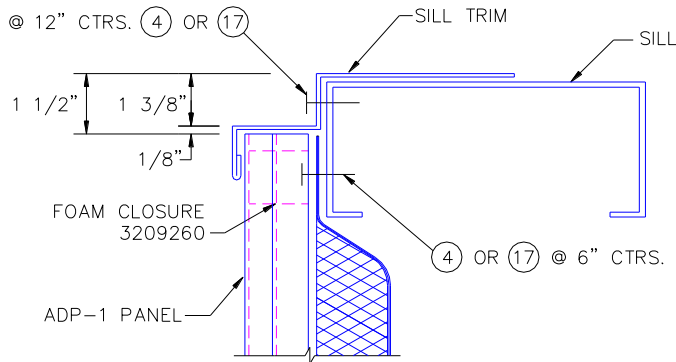

ILLUS. 6.31 PANELS AT SILL

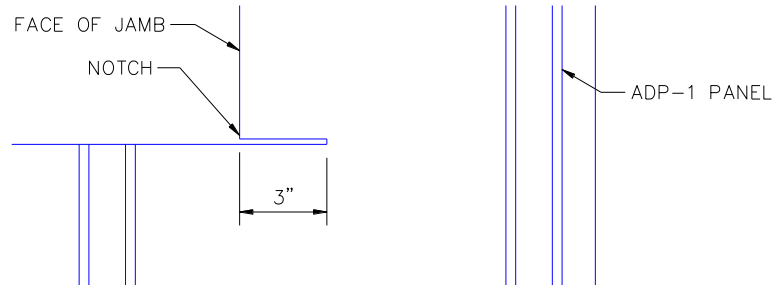

ILLUS. 6.32 NOTCHING PANELS FOR SILL TRIM

12. INSTALLING SILL TRIM

Position sill trim as shown above, extending 3" beyond the opening width at each side. Install foam closures along sill and secure with screws as shown in ILLUS. 4.5. Sill trim will be attached to the sill with screws at 12" centers see (above).

13. INSTALLING TRIMS ALONG JAMBS

Position the jamb trim stiffener over the wall panel and insulation facing as shown in ILLUS. 6.33 and attach to the jamb with structural screws. Attach jamb trim to jamb with structural screws and to the jamb trim stiffener with trim screws. Trims along the jamb will extend from the notch in the sill trim to the underside of the drip cap.

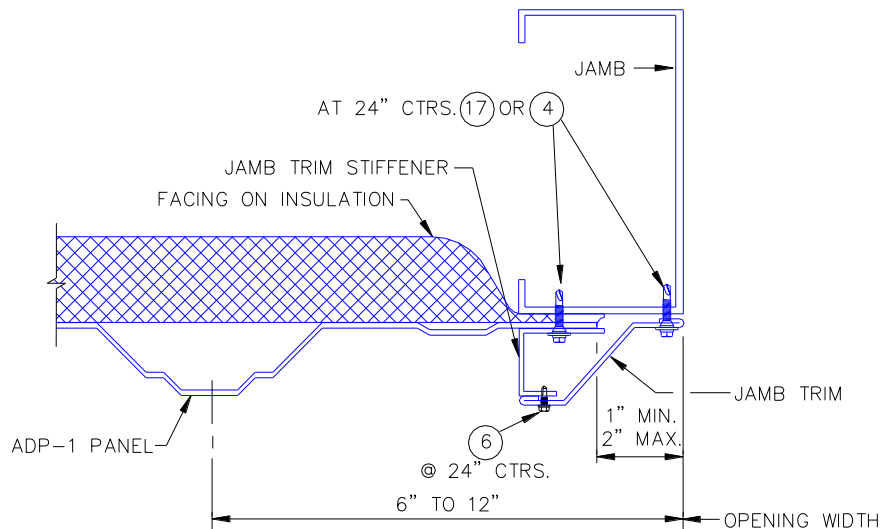

ILLUS. 6.33 TRIMS AT SIDE OF OPENING

6.G TRANSLUCENT WALL LIGHT

Three types of translucent wall lights can be used on the walls.

- a. Uninsulated stronglight, ADP profile, 10'-6" long, part number 3998089
- b. Uninsulated duralite, ADP profile, 10'-6" long part number 3998090

A typical location of translucent wall lights is along the sidewall near the eave. The upper end of wall light starts at the eave strut and ends 4" below a girt line (see ILLUS. 6.34).

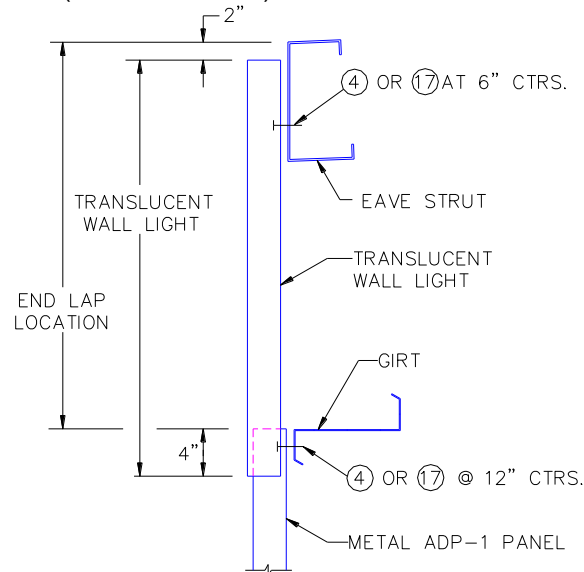

ILLUS. 6.34 TRANSLUCENT WALL LIGHT

Along the translucent wall light to metal panel sidelap a TM4-12 panel trim will be used to trim the opening and to contain the insulation (see ILLUS. 6.35). Structural fasteners will be used to attach translucent wall lights to the eave strut and through the endlap at a girt line.

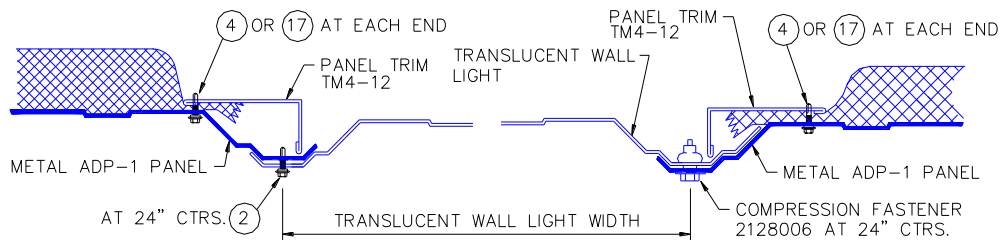

ILLUS. 6.35 SIDELAP OF TRANSLUCENT WALL LIGHT AND METAL PANEL

Use a ② self-drilling stitch screw at 24 inch centers on sidelaps.

When a sidelap is made with two translucent wall lights, a compression fastener will be used (See ILLUS. 6.36).

INSTALLATION:

1. Drill 3/8" diameter hole
2. Insert compression fastener shank into hole.
3. Tightening deforms shank

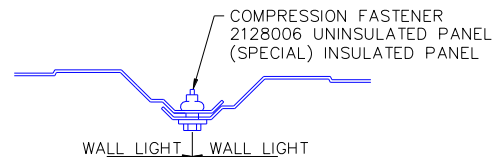

ILLUS. 6.36 SIDELAP OF TRANSLUCENT WALL LIGHTS

Compression fasteners will be used to attach roof perimeter trims to translucent wall lights.

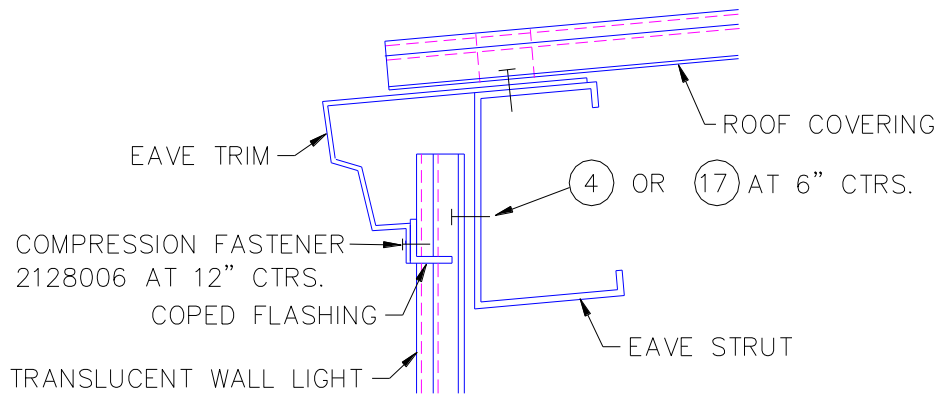

ILLUS. 6.37 ATTACHING TRIM TO TRANSLUCENT WALL LIGHT