

ZL-16® ZONAL LOCK®

Standing Seam Roof System ERECTION GUIDE

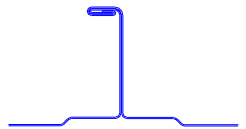

TRIPLE-LOCK

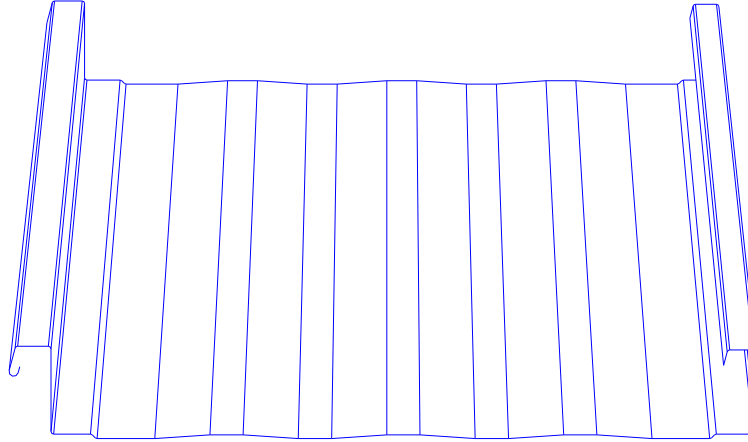
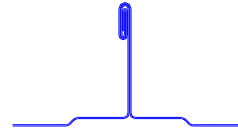

QUADRI-LOCK

B BEHLEN®
4025 E. 23rd St. • Box 569
Columbus, Nebraska 68601



Motorized Seamer Rental: www.qualityroofseamers.com

NOTE: See back side of cover for latest changes to this manual.

TECHNICAL INFORMATION 55068 8/29/08
Rev. 06/10/24

NOTE: If pink sheets are included in this manual, refer to them for latest revisions.

LATEST CHANGES		BY: SJW	DATE: 06/10/24
PAGE	CHANGE		
22	Updated the Touch-Up Paint information.		
31	Revised Fixed Clip part number to FC11200		
41	Added 3209410 Tape Sealant		
123	Revised Pipe Flashing detail		
128	Added QR Code for Quality Roof Seamer Website		

IMPORTANT NOTICE

Read this erection guide completely prior to starting the installation of the ZL-16 ® standing seam roof system. If there is a conflict between the project erection drawings and this guide, the project erection drawings will take precedence. Due to the process of continuous improvement, the products and procedures in this erection guide are subject to change without notice. Clarification concerning the roof installation should be directed to the Building Manufacturer Customer Service Manager.

CONTACT:

Behlen Mfg. Co.
4025 East 23rd Street
Columbus, NE 68601
Phone: 800-228-0340
Fax: 402-563-7405

ZL-16® Roof System Installation Guide

<u>TABLE of CONTENTS</u>	<u>PAGE</u>
1 GENERAL.....	6
1.1 PURPOSE OF THE INSTALLATION GUIDE.....	6
1.2 CUSTOMER’S RESPONSIBILITY.....	6
1.3 OWNER AND ERECTOR ADVISORIES.....	6
2 SAFE ROOF INSTALLATION.....	7
2.1 ERECTOR’S RESPONSIBILITY.....	7
2.2 OSHA.....	7
2.3 WALKING AND WORKING ON ROOF PANELS.....	7
2.4 HANDLING ROOF MATERIALS IN STRONG WINDS.....	8
3 CHECKING THE STRUCTURE.....	9
3.1 COMPLETED AND BRACED.....	9
3.2 LATERAL STABILITY.....	9
3.3 ALIGNMENT.....	9
4 RECEIVING AND HANDLING ROOF MATERIALS.....	10
4.1 MATERIAL INVENTORY.....	10
4.2 EQUIPMENT FOR UNLOADING AND LIFTING.....	10
4.3 LIFTING ROOF PANEL BUNDLES.....	11
4.4 FIELD STORAGE OF ROOF MATERIAL.....	11
4.5 HANDLING INDIVIDUAL ROOF PANELS.....	12
4.6 HANDLING LONG TRIM.....	12
4.7 PROTECTIVE FILM REMOVAL.....	13
5 ROOF INSTALLATION BASICS.....	13
5.1 PROPER TOOLS.....	13
5.2 EQUIPMENT LIST.....	13
5.3 SEALANTS.....	15
5.4 FASTENERS.....	16
5.5 INSTALLATION OF FASTENERS.....	16
5.6 TROUBLE SHOOTING GUIDE.....	18
5.7 TECHNICAL ASSISTANCE.....	20
5.8 FIELD CUTTING PANELS AND FLASHINGS.....	21
5.9 PROTECT ROOF PANELS FROM TRACKING.....	21
5.10 TOUCH-UP PAINT.....	22
5.11 INSULATION AND THERMAL BLOCK COMBINATIONS.....	23
6 ROOF PANEL LAYOUT.....	24
6.1 PANEL DESCRIPTION AND NOMENCLATURE.....	24
6.2 SHEETING DIRECTION AND MODULARITY.....	24
6.3 PANEL LAYOUT, START DIMENSIONS AND CHECKING FOR COVERAGE.....	26
6.4 APPEARANCE CONSIDERATIONS.....	27
7 INSPECTION OF ROOF ASSEMBLY DURING INSTALLATION.....	28
7.1 IMPORTANCE OF INSPECTION.....	28
7.2 INSPECTION LIST.....	28
8 STANDARD PARTS.....	30
8.1 GENERAL.....	30
8.2 ROOF COMPONENTS, EAVE AND RAKE PLATES.....	31
8.3 ROOF TRIMS.....	33
8.4 GUTTER COMPONENTS.....	34
8.5 GUTTER COMPONENTS.....	35

ZL-16® Roof System Installation Guide

8.6	RAKE TRIM AND DOWNSPOUT COMPONENTS	36
8.7	CORNER BOXES AND RIDGE COMPONENTS.....	37
8.8	TRIM AT ENDWALL PEAK	38
8.9	FASTENERS	39
8.10	MASTICS.....	40
9	ROOF INSTALLATION DETAILS	41
9.1	GENERAL	41
9.2	PREPARATION FOR ROOF PANEL INSTALLATION OVER A WOOD DECK.....	42
9.2.1	OREINTATION VIEW	42
9.2.2	INSTALL EAVE PLATE	43
9.2.3	INSTALL FIXED RAKE PLATE	44
9.2.4	INSTALL EAVE TRIM	45
9.2.5	INSTALL EAVE FLASHING.....	46
9.2.6	FIRST ROOF PANEL PLACEMENT AND PANEL OVERHANG VERIFICATION.....	47
9.2.7	ATTACHING PANEL CLIPS	50
9.2.8	ATTACHMENTS AT RIDGE	51
9.2.9	ATTACHMENTS AT HIGH EAVE	51
9.2.10	ATTACHMENTS AT RAKE.....	52
9.3	PREPARATION FOR ROOF PANEL INSTALLATION OVER SECONDARY FRAMING (PURLINS)	53
9.3.1	OREINTATION VIEW	53
9.3.2	INSTALL EAVE PLATE	54
9.3.3	INSTALL FIRST RUN OF INSULATION	55
9.3.4	SLIDING RAKE PLATE POSITIONED FOR RAKE TRIM.....	56
9.3.5	START SLIDING RAKE PLATE INSTALLATION.....	57
9.3.6	INSTALLING EAVE TRIM	58
9.3.7	INSTALLING EAVE FLASHING	59
9.4	ROOF PANEL INSTALLATION.....	60
9.4.1	ORIENTATION VIEW	60
9.4.2	FIRST ROOF PANEL PLACEMENT.....	61
9.4.3	PANEL OVERHANG VERIFICATION	63
9.4.4	ATTACHING ROOF PANEL AT EAVE.....	64
9.4.5	ATTACHING PANEL CLIP	65
9.4.6	TEMPORARY ROOF PANEL TIE-DOWN	66
9.5	CONSTRUCTING ENDLAPS	67
9.5.1	PANEL OVERHANG VERIFICATION	67
9.5.2	INSTALL TAPE AND GUN GRADE MASTICS	67
9.5.3	UPSLOPE PANEL PLACEMENT.....	69
9.5.4	PANEL ALIGNMENT	70
9.5.5	CLAMP THE SEAMS	71
9.5.6	INSTALL BACK-UP CHANNEL	72
9.5.7	INSTALL ENDLAP FASTENERS.....	73
9.6	PIGTAIL SEALANTS ALONG PANEL SEAM	75
9.6.1	LOCATION OF PIGTAILS.....	75
9.6.2	PIGTAIL SEALANT AT EAVE.....	75
9.6.3	PIGTAIL SEALANT AT ENDLAP	76
9.6.4	PIGTAIL SEALANT AT RIDGE OR HIGH EAVE END OF PANEL.....	76
9.7	INSTALL NEXT PANEL RUN.....	77
9.7.1	INSTALLING BACK-UP CHANNEL AT ENDLAP	77
9.7.2	ENGAGING PANEL SIDELAP	78
9.8	END DAM INSTALLATION.....	80
9.8.1	ORIENTATION VIEW	80
9.8.2	PREPARATION FOR END DAM INSTALLATION	81
9.8.3	INSTALL BACK-UP CHANNEL	82
9.8.4	INSTALLING TAPE AND GUN GRADE MASTICS	83
9.8.5	INSTALL END DAM	85
9.9	INSTALLING SUBSEQUENT PANEL RUNS	87
9.9.1	CHECKING PANEL COVERAGE	87

ZL-16® Roof System Installation Guide

9.9.2	ADJUSTING PANEL COVERAGE	88
9.10	TERMINATION PANEL INSTALLATION	89
9.10.1	INSTALL LAST PANEL RUN	89
9.11	RAKE TRIM INSTALLATION	90
9.11.1	ORIENTATION VIEW	90
9.11.2	INSTALL TAPE SEALANT ALONG RAKE	91
9.11.3	START RAKE TRIM AT EAVE	92
9.11.4	INSTALL SLIDE TRIM	93
9.11.5	RAKE TRIM ENDLAP	94
9.11.6	ENDING RAKE TRIM AT RIDGE	94
9.11.7	ENDING RAKE AT HIGH EAVE	95
9.11.8	TERMINATION OF END DAMS AT RAKE	95
9.12	RIDGE CAP INSTALLATION	96
9.12.1	RIDGE PANEL OVERHANG VERIFICATION	96
9.12.2	STARTING AT RAKE	96
9.12.3	RIDGE CAP ENDLAP	98
9.13	TERMINATION OF RIDGE AT RAKE	99
9.13.1	INSTALLING TAPE SEALANT	99
9.13.2	POSITION AND SECURE FLEXIBLE MEMBRANE	100
9.13.3	INSTALL PEAK FLASHINGS	101
9.13.4	INSTALL SIGN	102
9.14	HIGH EAVE TRIM INSTALLATION	103
9.14.1	PANEL OVERHANG VERIFICATION	103
9.14.2	PREPARATION FOR END DAM INSTALLATION	103
9.14.3	INSTALL BACK-UP CHANNEL AND END DAMS	103
9.14.4	POSITION HIGH EAVE TRIM AT CORNER	103
9.14.5	ATTACHING HIGH EAVE TRIM TO END DAMS	105
9.14.6	HIGH EAVE TRIM ENDLAPS	105
9.14.7	ATTACHING SIGN	105
9.14.8	FINISHING HIGH EAVE TRIM TO RAKE AT CORNER	106
9.15	LOW EAVE TO RAKE, CORNER TRIMS	106
9.15.1	EAVE TRIM TO RAKE	106
9.15.2	EAVE FLASHING TO RAKE	107
9.16	STANDARD AND HIGH CAPACITY GUTTER INSTALLATION	107
9.16.1	PANEL OVERHANG VERIFICATION	107
9.16.2	INSTALL GUTTER END CAP	108
9.16.3	POSITIONING FIRST GUTTER SECTION	108
9.16.4	INSTALLING GUTTER HANGERS	109
9.16.5	SPLICING GUTTER	110
9.16.6	INSTALLING GUTTER EXPANSION JOINT	110
9.16.7	FINISHING STANDARD GUTTER TO RAKE AT CORNER	111
9.16.8	FINISHING HIGH CAPACITY GUTTER TO RAKE AT CORNER	111
9.17	RIB CONCEALING AND HIGH CAPACITY GUTTER INSTALLATION	112
9.17.1	PANEL OVERHANG VERIFICATION	112
9.17.2	INSTALL GUTTER END CAP	112
9.17.3	POSITIONING FIRST GUTTER SECTION	113
9.17.4	INSTALLING GUTTER HANGERS	114
9.17.5	SPLICING GUTTER	114
9.17.6	INSTALLING GUTTER EXPANSION JOINT	115
9.17.7	INSTALL OUTSIDE CORNER BOX AND END CAP TO RIB CONCEALING GUTTER	115
9.17.8	INSTALL OUTSIDE CORNER BOX AND END CAP TO RIB CONCEALING (HC) GUTTER	116
9.17.9	FINISHING RIB CONCEALING GUTTER TO RAKE, AT CORNER	116
10	DOWNSPOUT INSTALLATION	117
10.1	LOCATING DOWNSPOUTS	117
10.2	CUTTING BOTTOM OF GUTTER AND ATTACHING DOWNSPOUT	117
10.3	SPLICING DOWNSPOUTS	118
10.4	SECURING DOWNSPOUT TO WALL	118

ZL-16® Roof System Installation Guide

10.5	INSTALL ELBOW	118
11	ROOF ACCESSORIES	119
11.1	PRE-VENT® (LOW PROFILE) RIDGE VENTILATION SYSTEM.....	119
11.1.1	MODIFICATIONS TO RIDGE COMPONENTS	119
11.1.2	RIDGE PANEL OVERHANG VERIFICATION	120
11.1.3	INSTALL BACK-UP CHANNEL AND END DAMS.....	121
11.1.4	INSTALL PRE-VENT® MATERIAL	121
11.1.5	INSTALLING RIDGE CAP.....	121
11.1.6	INSTALL END CAPS AT END OF RUN.....	122
11.2	PIPE FLASHING	123
11.3	ROOF CLAMP.....	124
12	ROOF SEAMING GENERAL INFORMATION	125
12.1	GENERAL	125
12.2	SEAM TYPES.....	125
12.2.1	GENERAL	125
12.2.2	TRIPE – LOCK SEAM	125
12.2.3	QUADRI – LOCK SEAM.....	126
12.3	CHECK PANEL ASSEMBLY	126
12.3.1	SIDELAP FIT-UP	126
12.3.2	CLIP ALIGNMENT	126
12.3.3	SEAM DAMAGE	126
13	IMPORTANCE OF SEAMING.....	126
13.1	ROOF PERFORMANCE	126
13.2	WHEN TO SEAM	126
13.3	TEMPORARY SEAMING.....	127
14	SEAMING EQUIPMENT	127
14.1	SPECIALIZED SEAMING TOOLS.....	127
14.2	SEAMING TOOL SOURCE	127
14.3	MOTOR SEAMING MACHINES.....	128
14.4	HANDLING SEAMER	128
15	ELECTRICAL REQUIREMENTS.....	129
15.1	MOTOR SEAMING MACHINES.....	129
15.2	ELECTRICAL SERVICE AND CORDS	129
15.3	ELECTRICAL SAFELY	129
15.4	CORD CLEARANCE	129
16	MANUAL SEAMING TOOL OPERATION	129
16.1	MANUAL SEAMING TOOL TYPES AND NOMENCLATURE	129
16.2	TOOL ORIENTATION TO SEAM.....	130
16.3	FORMING THE SEAM.....	130
16.4	TOOL POSITION AT END OF PANEL	131
16.5	TOOL POSITION AT PANEL ENDLAP	131
16.6	TOOL POSITION AT PANEL CLIPS	132
16.7	CHECKING THE FINISHED SEAM	132
17	QUADRI-LOCK MANUAL SEAMING TOOL OPERATION	133
17.1	TOOL NOMENCLATURE.....	133
17.2	TOOL ORIENTATION TO SEAM.....	133
17.3	CHECKING THE FINISHED SEAM	134
18	MOTOR SEAMING MACHINE OPERATION.....	134
18.1	CLEAN THE SEAMS	134
18.2	RUNNING THE SEAMER.....	134

ZL-16® Roof System Installation Guide

19	TRIPLE-LOCK SEAMING.....	135
19.1	MANUAL SEAMING	135
19.2	MOTOR SEAMING	135
19.3	FINISH SEAM DETAIL.....	135
20	QUADRI-LOCK SEAMING.....	136
20.1	MANUAL SEAMING	136
20.2	MOTOR SEAMING	136
20.3	FINISH SEAM DETAIL.....	136
21	PANEL REPLACEMENT PROCEDURE	137
21.1	GENERAL	137
21.2	DETERMINE THE DAMAGED PANEL AREA.....	137
21.3	REMOVE EAVE AND RIDGE ATTACHMENTS.....	138
21.4	UN-SEAMING TOOL	138
21.5	UNFOLD STARTING AND FINISH SEAMS.....	139
21.6	DISENGAGE THE STARTING AND FINISH SEAMS.....	139
21.7	REMOVE DAMAGED PANELS.....	140
21.8	STARTING SEAM PREPARATION.....	140
21.9	FINISH SEAM PREPARATION.....	141
21.10	PREPARATION OF LAST REPLACEMENT PANEL	141
21.11	INSTALL REPLACEMENT ROOF PANELS.....	142
21.12	CLOSE THE FINISH SEAM	142
21.13	FOLDING THE FINISH SEAM	142
21.14	SEAMING THE FINISH SEAM.....	142

ZL-16® Roof System Installation Guide

1 GENERAL

1.1 PURPOSE OF THE INSTALLATION GUIDE

This installation guide is provided to customers and their erectors as the recommended procedure for the correct assembly of the ZL-16® standing seam roof system, here after referred to as the standing seam roof system.

This guide is intended to be used in conjunction with the project's erection drawings to help plan and organize the installation of the Standing Seam Roof System. The erection drawings identify the applicable roof conditions and govern specific part arrangements. The instructions will help you identify parts, establish the installation sequence, demonstrate correct assembly, and point out any areas or procedures requiring special emphasis or attention. This installation guide applies to the standard Standing Seam Roof System. Custom roof conditions, including custom details and instructions, will be covered by the erection drawings. In case of conflict between this installation guide and the erection drawings, the erection drawings will have precedence.

1.2 CUSTOMER'S RESPONSIBILITY

The customer is responsible for proper installation of the roof in accordance with the erection drawings and this installation guide, and in accordance with good engineering and construction practices.

The customer must take the responsibility for selecting a competent erector, insist that the work be performed by qualified and experienced standing seam metal roof installers, and insist that the erector take time to study and understand this guide, then assure that the erector correctly follows the guide's instructions.

The building manufacturer does not guarantee and is not liable for the quality of erection. The building manufacturer is not responsible for building defects that may be attributed to improper erection or the negligence of other parties.

Clarification concerning the roof installation should be directed to the building manufacturer's customer service manager.

1.3 OWNER AND ERECTOR ADVISORIES

Never use pressure treated wood to support conduit, piping and other roof top utilities or equipment. The salts used to preserve the wood are extremely corrosive and wood resting on the metal roof panel will trap moisture between the metal and the wood. Untreated wood will trap moisture and cause much slower corrosion, by means of acidifying the trapped water.

Never allow copper cable or zinc coated copper cable as part of a lightening arreston system to touch a metal roof. This is extremely corrosive.

Never install unpainted black iron pipe for gas or condensate piping on a metal roof. It will corrode quickly and the rust particles will slough off and begin corroding the panel.

Never allow any trade to cut or weld, thread or grind any metal to fabricate pipe systems conduit runs or other items on the roof. Hot metal shavings and sharp cuttings can embed in the acrylic or painted coating and cause pinhole corrosion.

Never allow rain water from an upper roof to discharge directly onto the roof panels from downspouts. Use splash pads or continue piping the water down. Rainwater picks up grit and the high velocity of discharge uses the grit to erode protective coatings, causing corrosion.

Minimize roof penetrations. Do not drill and fasten any sort of fixture to the roof. This is a reliable way to cause roof leakage.

Use roof walk grating mounted on standing seam panels indirectly with non-penetrating seam clips, such as S-5U and painted or galvanized framing if frequent foot traffic is expected. Grit on shoe soles abrades the surface. The frequent traffic can create panel tensions that work to loosen seams and crimps at the clips. Foot traffic can promote oil-canning and local ponding of rainwater on the roof. Rubber and fibrous walk mats are not as good as walk grating. They trap water between the mat and panel and can promote corrosion.

8/29/08

ZL-16® Roof System Installation Guide

The roof owner is responsible for protecting the roof from damage and performing regular maintenance such as removal of excess snow and ice, frequent clearing of drainage systems and immediate repair of roof damage.

2 SAFE ROOF INSTALLATION

2.1 ERECTOR'S RESPONSIBILITY

The erector of the roof system is responsible for the safe execution of this installation guide. These instructions are intended to describe the sequence and proper placement of parts. They are not intended to prescribe comprehensive safety procedures.

If the erector cannot safely assemble the roof in accordance with these instructions, it is the responsibility of the erector to stop the work and contact building manufacturer to determine alternate assembly procedures.

2.2 OSHA

The Occupational Safety and Health Act (OSHA) have promulgated many regulations applicable to the installation of this or any other roof system. These regulations, identified as Part 1926, Safety and Health Regulations for Construction, are available from any government bookstore. The objective of the OSHA standards is to protect the worker from injury or illness. These OSHA regulations should be recognized as job site requirements and be fully complied with.

Failure to do so may result in substantial fines in the event of an OSHA inspection. Safe installation practices may be further defined and made mandatory by state or local ordinances.

Maintaining good housekeeping on the jobsite is recognized as being important to both OSHA compliance and to successful job completion.

2.3 WALKING AND WORKING ON ROOF PANELS

A. PLACING PANELS ON THE STRUCTURE

Do not place bundles of panels on the roof structure without first verifying the structure will safely support the concentrated weight of the panels and the weight of the installation crew. Some roof structures may not be designed to support the weight of a full panel bundle without additional structure support.

B. WALKING ON ROOF PANELS

Do not use a roof panel as a working platform. An unsecured panel could collapse under the weight of a person standing between purlins or at the panel end.

Do not walk on the last installed panel run, as the unsecured edge could collapse under a person's weight. When installing clips or making endlap connections etc. Stand where the roof structural will support your weight.

An approved and safe walking platform should be used in high traffic areas to prevent the roof panel from being deformed, scratched, or scuffed.

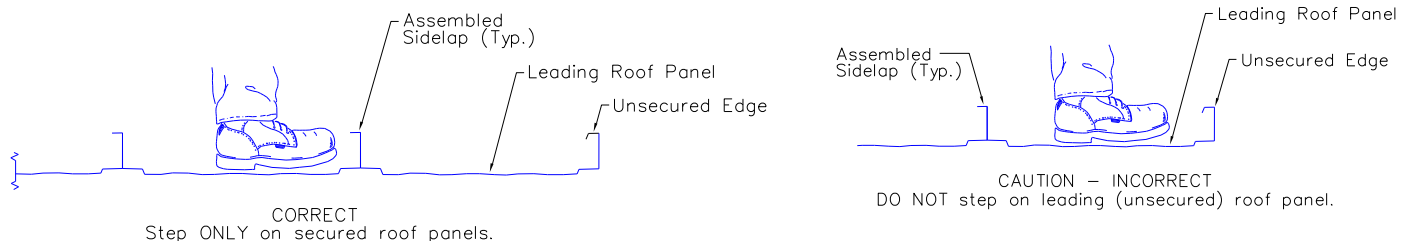

Foot traffic on the roof panels can cause permanent distortion of the panel surface. This distortion causes or contributes to visible oil-canning. This is especially critical for roofs with stand-off, because the panels may not have uniform solid support to help resist the foot traffic damage.

On roofs where minimum visible oil-canning is a critical requirement, the roof erection must be conducted in a manner that eliminates floor traffic on the roof panels. In all other cases, foot traffic should be minimized and must be limited to only those areas where the panel surface has solid support, such as directly over a joist or spacer block, etc.

ZL-16® Roof System Installation Guide

C. SAFETY EQUIPMENT

The use of safety equipment for the roof panel installation is recommended at all times during the installation process. However, when using lanyards, ensure that the clasp, belt hooks and wire cables are covered in such a manner that they will not scratch the panel surface if accidentally dragged along the panel. All workers should be tied-off to the rigid frames, do not use the purlins to tie-off.

D. CREW SIZE

The length of the individual roof panels should be considered when determining the crew size. It is recommended that under normal conditions, there be one person for every ten feet of panel length, plus one.

E. PANEL OVERHANG

Do not stand on the end of unsupported (cantilevered) panels at the eave or ridge. Standing on the cantilever portion may result in panel collapse.

F. POINT LOADS

When properly supported by the structurals, panels are designed to support uniform loads, which are evenly distributed over the panel surfaces. Point loads that occur in small or concentrated areas, such as heavy equipment, ladder or platform feet, etc., may cause panel deformation or even panel collapse.

G. SLICK SURFACES

Panel surfaces and structural steel surfaces are hard, smooth, and nonabsorbent, which causes these surfaces to be very slick when wet or covered with snow or ice. Even blowing sand or heavy dust can make these surfaces difficult to walk on without slipping.

Unpainted panel surfaces are often coated with oil to accommodate the panel-fabrication process. Although designed to wash away or evaporate during normal weather, the oil on new panels can be extremely slick, especially during periods of light rain or dew.

Caution must be exercised to prevent slipping and falling onto the roof surface or even sliding off the roof. Non-slip footwear is a necessity and non-slip working platforms are recommended.

H. ELECTRICAL CONDUCTANCE

Metal panels are excellent electrical conductors. A common cause of injury is the contact of metal panels with power lines during handling and installation. The location of all power lines must be noted and, if possible, flagged. The installation process must be routed to avoid accidental contact with all power lines and high voltage services and equipment. All tools and power cords must be properly insulated and grounded and the use of approved ground fault circuit breakers is recommended.

I. FALSE SECURITY OF INSULATION

Blanket and board insulation blocks the installer's view of the ground below the roof. Serious injury can occur when the installer gets a false sense of security because he cannot see the ground and steps through the insulation.

J. SHARP EDGES

Some edges of panels and flashing are razor sharp and can cause severe cuts if proper protective hand gear is not worn. Be careful not to injure others while moving panels and flashing.

2.4 HANDLING ROOF MATERIALS IN STRONG WINDS

Do not attempt to move panels in strong winds. Wind pressure can easily cause a man to lose balance and fall. Strong wind uplift on a panel can lift the weight of the man carrying the panel.

Loose, wind borne panels are very dangerous and can cause severe injury and damage.

Secure stacks of panels with banding or tie-downs, so wind will not blow the panels off the roof. Clamp individual unsecured panels to the roof structurals. Clamp or block panel bundles and accessory crates to prevent them from sliding down the roof slope.

3 CHECKING THE STRUCTURE

3.1 COMPLETED AND BRACED

Before placing materials and workers on the roof structure to start roof installation, it must be confirmed that the structure is designed to accommodate the material and erection loads as well as the appropriate live loads and wind uplift loads.

It also must be determined that the structure is complete and structurally sound with all structural connections and bracing in place and secure.

3.2 LATERAL STABILITY

The sliding clip method of attaching the roof panels to the roof structurals provides only limited lateral stability and diaphragm bracing to the roof structurals.

Before placing materials on the roof and starting the roof installation, confirm that the necessary roof bracing is in place and secured.

3.3 ALIGNMENT

Prior to installation, roof structurals should be checked for overall dimensions and evenness of plane. The roof structurals should also be checked to verify the roof system could be installed without interference. Also, roof structurals nearest the panel endlaps, ridge or high eave should be checked for correct location to properly accommodate the roof components.

A. TOLERANCES

To assure the roof system's correct fit-up and designed weather tightness, the structure must be aligned within the following tolerances:

Out of Square — The roof system can only accommodate 1/4" of saw tooth of the roof panel ends at the eave, ridge and panel splices. This means the allowable out of square of the rake line relative to the eave line and ridge line is 1/4" for each 40' of rake run.

Structure Width and Eave Straightness — The roof system is designed to accommodate $\pm 2"$ of overall structure width error, or $\pm 1"$ of eave straightness error at each eave.

To assure that the accumulation of the structure width error and eave straightness error does not exceed the roof system's tolerance, the structure width should be measured from eave line to eave line at each rake, at the first frame line from each rake and at each point where there is a significant error or change in eave straightness (this usually occurs at a frame line or at a wind column).

Structure Length and Rake Straightness — The roof system is designed to accommodate $\pm 2"$ of overall structure length error, or $\pm 1"$ of rake straightness error at each rake.

To assure that the accumulation of structure length error and rake straightness error does not exceed the roof system's tolerance, the structure length should be measured from rake line to rake line at each eave, at the ridge and at each point where there is a significant error or change in rake straightness (this usually occurs at an end rafter splice).

B. MEASURING

Structure length and width may be measured with a steel measuring tape from the face of the eave or rake member to the face of the opposite eave or rake member. The measuring tape must be parallel to the relative eave or rake line and must be stretched taut.

Eave and rake straightness may be determined by measuring deviations from a string line, which is stretched taut along the eave or rake line.

C. AESTHETIC ACCEPTANCE

Although these structure alignment tolerances will allow for reasonable roof component fit-up and ease of installation, the extremes of these tolerances may be aesthetically objectionable and should be confirmed with the customer before starting the roof installation.

ZL-16® Roof System Installation Guide

D. CORRECTIONS

Any structure alignment error, which exceeds the above stated tolerances, must be corrected before roof installation can begin. If it is decided that the structure alignment errors cannot be corrected, alternate roof details may have to be developed. The alternate details may require additional materials, modified parts (with additional cost, fabrication and delivery time) and additional installation time. The building manufacturer cannot assure the performance of such alternate details.

4 RECEIVING AND HANDLING ROOF MATERIALS

4.1 MATERIAL INVENTORY

Your material is carefully inspected and crated before leaving the plant and accepted by the transportation company as being complete and in satisfactory condition. It is the carrier's responsibility to deliver the shipment intact. It is the consignee's responsibility to inspect the shipment for damages and shortages when it is delivered.

Conducting a material inventory at the time of delivery is essential. By conducting the materials inventory, the erector is able to identify any material shortage or damage and avoid stopping installation later because of such shortage or damage.

It is imperative that any shortages or damage of the delivered materials be noted at once and clearly marked on the bill of lading before signature of acceptance. Notify the building manufacturer immediately of any conflicts. The building manufacturer will not be responsible for shortages or damages unless they are noted on the bill of lading.

In the case of packaged components (such as clips, fasteners and sealants, etc.), the quantities are marked on their container and should be checked against the bill of materials. The building **manufacturer must be notified of any shortages or concealed damage within 15 days of delivery.**

4.2 EQUIPMENT FOR UNLOADING AND LIFTING

Hoisting equipment is necessary to unload and position the panels and accessory crates for site storage and installation. The equipment must have sufficient capacity and reach to place the material where it is required for efficient installation.

Slings will be required to minimize panel damage. The recommended slings are nylon straps of 6" minimum width and of sufficient length to accommodate the panel bundle girth.

A spreader bar will be required for the longer panel crates to assure correct sling spacing and uniform lifting. The spreader bar must be large enough to handle the maximum panel bundle weight and length.

A forklift is handy for unloading and placing shorter panel and accessory crates.

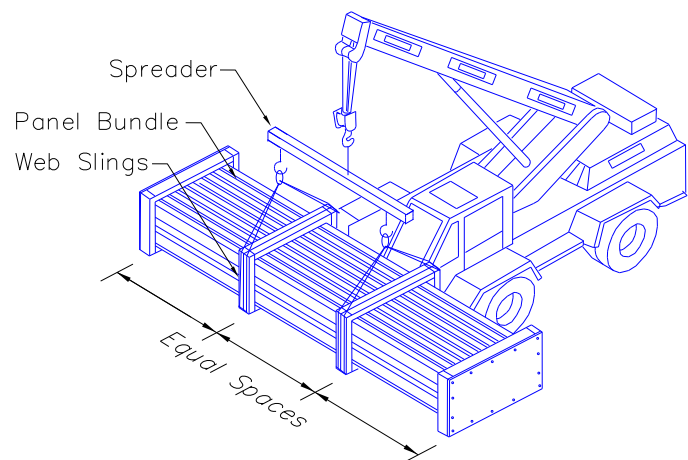
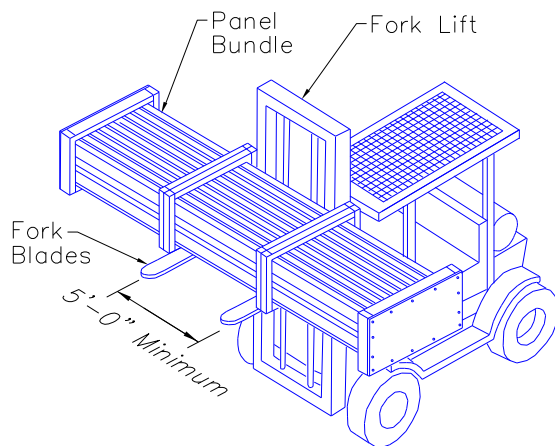

8/29/08

ZL-16® Roof System Installation Guide

4.3 LIFTING ROOF PANEL BUNDLES

Under normal conditions, panel crates less than 35' long can be lifted with two slings spaced at third points. Panel crates longer than 35' can be lifted with three slings located at quarter points using a spreader bar to achieve correct sling spacing for uniform lift.

Slings should be located at the banding locations. Loads should always be checked for secure hook-up, proper balance, and lift clearance. Tag lines should be used if necessary to control the load during lifting, especially if operating in the wind.

Panel crates less than 15' long may be lifted with a forklift only if the forks are spread at least 5' apart and blocking is used to prevent panel damage by the forks.

The number of panels in a typical bundle will be 20. The table below gives approximate weights of various panel lifts.

PANEL LENGTH	TOTAL WEIGHT OF 20 PANEL BUNDLE	PANEL LENGTH	TOTAL WEIGHT OF 20 PANEL BUNDLE
10'	537	35'	1864
15'	802	40'	2125
20'	1075	45'	2402
24'	1284	50'	2679
30'	1602		

Banding on panel bundles must be left intact until all lifting is complete. Lift one bundle at a time.

4.4 FIELD STORAGE OF ROOF MATERIAL

Upon acceptance of the shipment, the customer or his representative is responsible for proper handling storage and security of the roof materials. The building manufacturer is not liable for damage or loss of materials at the job site.

Outside job site storage of all building components should be limited to a short duration just prior to erection and when site conditions are favorable. Warehouse storage should be used when adverse field conditions or long-term storage is anticipated.

Coated steel panels are subject to corrosion and discoloration if moisture becomes entrapped between panels. Inspect panels for entrapped moisture upon arrival at the job site and properly protect and store them in order to prevent accumulation of moisture between panels.

In addition to moisture due to rainfall, moisture can also form between panels due to condensation. When panels are not expected to be immediately installed, inside storage is recommended.

When outside storage is necessary, store in accordance with the following criteria:

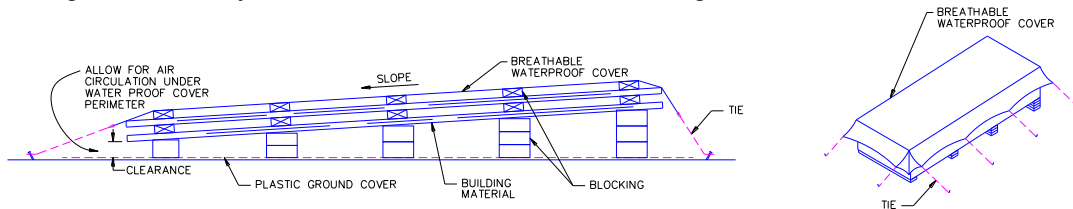

- Store panels in a protected area, out of standing water and drifting snow, etc.
- When panels are stored on the ground, use a plastic ground cover to minimize condensation of moisture from the ground onto the panels.
- Raise the bundles off the plastic ground cover to prevent contact with water puddles, and allow for air circulation over, under, and through the bundles to resist creation of and promote the evaporation of any condensed moisture.
- Provide sufficient blocking to raise and support the bundles to prevent excessive bowing.
- Slope panels for drainage of moisture from the panels.
- Cover panels with a breathable waterproof cover, allowing for air circulation (do not wrap cover under panel bundles or restrict air movement).
- Inspect panels daily for moisture accumulation.
- If panel bundles contain moisture, the panels must be dried and restacked. Use care in restacking to not damage panels.
- Secure opened or restacked panel bundles to prevent damage.

ZL-16® Roof System Installation Guide

When moving panel bundles, take extreme caution to prevent damage to the panel edges. Support uncrated panels at each end and at 6' spaces.

Secure all bundles or loose panels on the roof to the roof structurals at the end of each workday. On steep roofs, take provisions to prevent panels and panel crates from sliding off the roof. Be sure to set panel bundles on the roof in the proper direction for the installation sequence.

Store trim and accessories in a secure area and protected from damage, weather, and theft. Store fasteners, sealants, closures, etc. out of the weather and protected from contamination.

4.5 HANDLING INDIVIDUAL ROOF PANELS

To lift individual panels, lift one side of the panel by the seam letting it hang naturally to prevent buckling. Pick-up points should not be more than 10' apart. Do not pick-up panels by the ends only, or in a flat position.

If the individual panels are to be lifted to the roof by hand line, the common method is to use the vice grip "C" clamps. Position the clamps on the flat of the panel, as close as possible to one edge so the panel is lifted in a vertical position. The jaws of the vice grips must be padded to prevent damage to the panel surface. Space clamps uniformly, no more than 10' apart and the hand lines must be pulled in unison so that uneven lifting does not buckle the panel. Be sure the clamps are tight on the panel and the line is secure to prevent dropping the panel, which can result in personal injury and property damage.

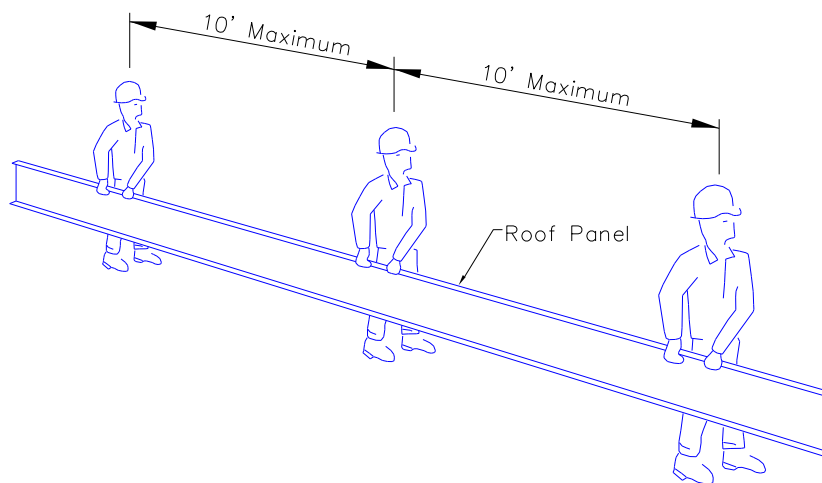

4.6 HANDLING LONG TRIM

When removing long trim from the shipping crate and during installation, take care to prevent damage caused by buckling. Lift with two or more people; do not pick trim up by ends.

ZL-16® Roof System Installation Guide

4.7 PROTECTIVE FILM REMOVAL

Trim components have a protective film on the colored surface that must be removed prior to installation. Prolonged exposure (more than 3 weeks) to rain and/or sunlight will adversely affect the protective film making removal difficult.

REMOVAL INSTRUCTIONS

When film is being removed from trim having a hem along its edge, the film should be peeled off along the entire end. This includes the 3/8" hemmed area, on the back side. Pull the entire film strip at a constant rate. Do **NOT** try to rip the film off as it will tend to tear at the hemmed edge and corners leaving a strip that will have to be removed separately.

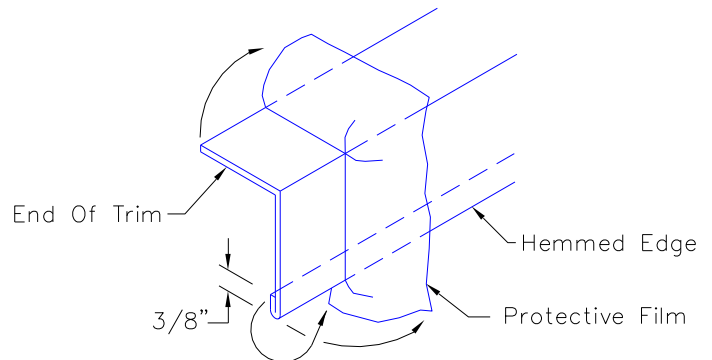

5 ROOF INSTALLATION BASICS

5.1 PROPER TOOLS

Before starting paneling, be sure that the proper equipment and tools are on hand. The tools must be in good operating condition and operators should adhere to safety precautions at all times.

Improperly operating tools, too few tools, inadequate power source, or other equipment deficiencies slow down the installation process. The cost of inefficient working is usually greater than the cost of providing good equipment.

5.2 EQUIPMENT LIST

The following tools and equipment should be considered for efficient installation of the standing seam roof system. Actual tools and equipment required may vary due to variations in building type and construction.

This list should not be interpreted as a limitation to your inventory of installation equipment. Tools (A thru D) are specifically designed for the standing seam panel and are available from the building manufacturer.

A. MANUAL SEAMING TOOLS

Either tool can be used to form the panel seam to a Triple-Lock profile at: Panel clips, Endlaps and panel ends at eaves and ridge lines.

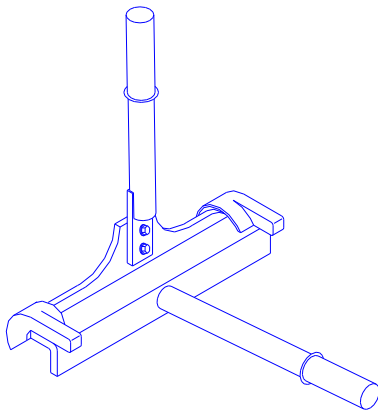

HAND SEAMER TOOL 3518052

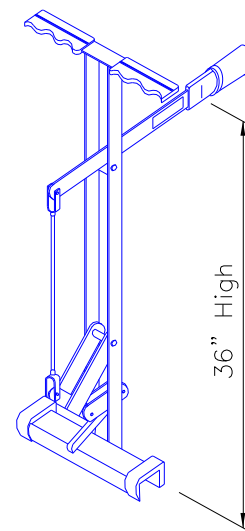

STAND-UP SEAMER 255139

3/2/09

ZL-16® Roof System Installation Guide

B. SEAM CLAMP (Part No. 255133)

Used to compress tape mastic at panel endlaps. Minimum of (2) required.

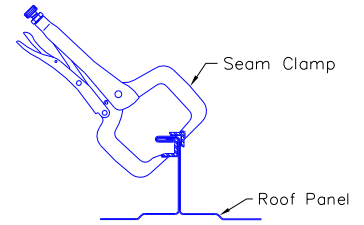

C. RIB CLAMP (Part No. 255143)

Used to correct roof panel coverage by squeezing ribs together to provide a consistent coverage with a minimum of (2) required.

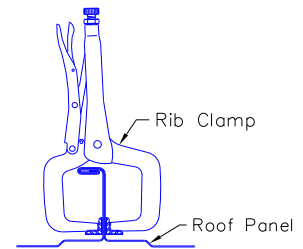

D. QUADRI-LOCK SEAMING TOOL (Part No. 3518053)

Used to form the panel seam to a Quadri-Lock profile.

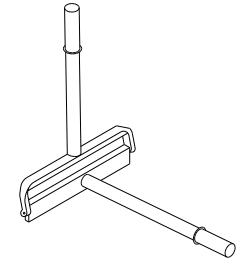

E. MOTORIZED SEAMING MACHINE

For motorized seaming machine rental information refer to page 128 in this manual.

F. OTHER TOOLS AND EQUIPMENT

Screw Guns — Designed for use with self-drilling screws

Socket Extensions — 6" extension for screw gun

Hex Socket Heads — 5/16" magnetic

Drill Motor — 1/4" capacity

Drill Bits — Assortment

Sheet Metal Cutter — or power shears or nibbler

"C" Clamps — vise grip type

Sheet Metal Shears — left and right cut

Hack Saw — with metal cutting blade

Steel Measuring Tape — 12', 50', 100'

Nylon String Lines

Chalk Line

Brooms

Marking Pen

Caulk Guns — for 1/10 gallon sealant tubes

Power Source and Extension Cords — capable of handling the total equipment requirements, including 20-amp seamer machine, without power drop due to extension cord length.

ZL-16® Roof System Installation Guide

5.3 SEALANTS

A. TEMPERATURE EFFECTS

Temperature extremes must be considered during installation of the roof due to the sensitivity of sealants. The recommended installation temperature range is 20° F to 120° F. At colder temperatures, the sealant stiffens resulting in loss of adhesion and compressibility. At hotter temperatures, the sealant becomes too soft for practical handling. On cold but sunny days, the panel's surface may become warm enough to accept the application of a heated sealant even though the air temperature is below 20° F.

When overnight temperatures fall below freezing, the sealant should be stored in a heated room so it will be warm enough to use the following day. On hot days, the sealant cartons should be stored off the roof in a cool and shaded area. While on the roof, sealant rolls should be kept shaded until actual use.

In very cold weather, it is recommended that the fasteners be tightened slowly and only tight enough that the sealant is in full contact with the panel or flashing. Then on the next sunny day, complete the tightening process after the sun warms the panel and flashing surfaces.

B. CONTAMINATION

To assure proper adhesion and sealing, the sealant must have complete contact with adjoining surfaces. Contaminants such as water, oil, dirt and dust prevent such contact. The panel and flashing surfaces must be dry and thoroughly cleaned of all contaminants. Before applying tape sealant, the sealant should be checked for contaminants. If the sealant surfaces are contaminated, it must not be used.

During cool weather, condensation or light mist can accumulate on the panel and flashing surface and not be easily noticed. It is recommended that sealants always be kept under protective cover and that the panel and flashing surfaces be wiped dry immediately before installation.

Tape sealant is provided with a protective paper to reduce contamination. Incomplete removal of the protective paper will prevent the sealant's adhesion to the panel or flashing surfaces. Always check that the protective paper is completely removed. Do not remove the protective paper until immediately before the panel or flashing is installed over the sealant.

C. COMPRESSION

To assure proper adhesion and seal, the tape sealant must be compressed between the panel and flashing surfaces with firm and uniform pressure. In most cases, the required pressure is applied by the clamping action of screws pulling the adjoining surfaces together. However, the tape sealant's resistance to pressure becomes greater in cold weather.

During cold weather, the fasteners must be tightened slowly to allow the sealant time to compress. If the fasteners are tightened too fast, the fastener may strip out before the sealant compresses adequately, or the panel or flash may deform in the immediate area of the fastener, leaving the rest of the sealant insufficiently compressed.

D. INSIDE CORNERS

An inside radius, such as where the panel flat meets a rib, is usually the most critical area to seal. A common mistake for the installer, is to bridge the sealant across the inside radius.

When the lapping panel or flashing is pushed into place, the bridged sealant is stretched and thinned. The sealant may then be too thin to adequately seal this critical area. When tape sealant is applied at an inside radius, it is recommended that the sealant be folded back on itself, then push the sealant fold into the radius.

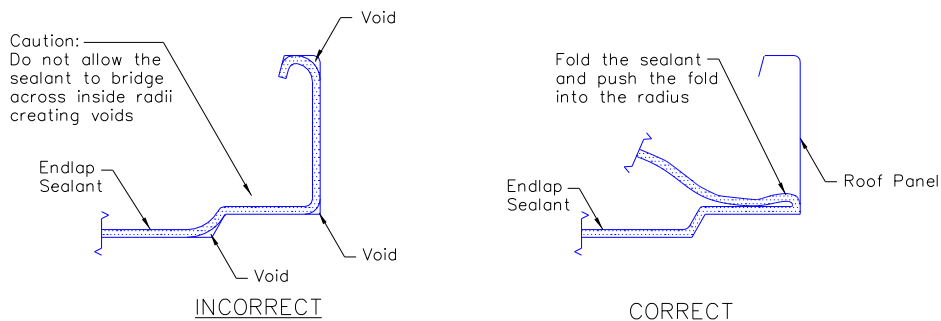

ZL-16® Roof System Installation Guide

E. LAPS

Splice mastic with a 2" overlap. Press lapped tape mastic strips firmly together to form a single thickness.



5.4 FASTENERS

A. SCREW GUN

Use torque control screw guns for driving self-drilling screws. 1800 RPM screw gun speed is necessary to attain efficient drilling speeds. High tool amperage (4 to 7 AMP) is required to achieve the proper torque for secure fastening.

B. SOCKETS

Use good quality magnetic sockets. Good fitting sockets reduce wobble and stripping of the screw heads, especially the zinc-die cast heads. They also minimize objectionable paint chipping and scuffing on colored screws and minimize damage to the protective coating on unpainted screws. See Section 5.7 for additional information on socket types.

Magnetic sockets collect drill shavings, which will build up and eventually prevent the socket from seating properly on the screw heads. One method of removing the drill shavings is to roll up a ball of tape sealant and push the socket into the sealant.

When the socket is removed from the sealant, most of the drill shavings will remain embedded in the sealant thereby cleaning the socket. This process should be repeated as often as needed to keep the socket clear of drill shavings.

C. SOCKET EXTENSION

A 4" or 6" socket extension is recommended for installing the panel clip screws. With the extension the screw can be driven straight down without tilting the screw gun to clear the panel or clip. Since socket extensions are slow to wear out, it is usually more cost effective to purchase socket extensions and good quality sockets rather than purchase sockets with built-in extensions.

5.5 INSTALLATION OF FASTENERS

Before starting the screw, the materials to be joined must be pressed together with foot or hand pressure. The pressure must be maintained until the screw has drilled through all the materials and the threads have engaged.

Most self-drilling screws require 20 pounds of pressure to maintain the drilling action and to start the thread cutting action. Also, applying such pressure before starting the screw gun will usually prevent tip walking or wandering. If too little pressure is applied, the drill point may not cut into the metal and the point will heat up and become dull. If the pressure is too heavy, the bottom material may be deflected away, causing a standoff condition, or the drill tip may be broken or split. Screws must be held perpendicular to the panel or flashing surface during starting and driving.

For proper seating of the fastener-sealing washer, the panel or flashing surface must be clean and drill shavings must be removed from under washers before seating. The fastener must be driven perpendicular to the panel surface so that the washer can seat level without warping or cupping.

Do not over drive screws. Over driving can strip the threads and/or damage the sealing washer. Use screw gun with torque control set to function properly for the combination of fastener size, hole size and material thickness.

The fastener should be driven tight enough to uniformly compress the washer but not so tight that the washer splits or rolls out from under its metal dome. The recommended procedure is to tighten the fastener until the sealing washer just starts to visually bulge from under the metal dome.



8/29/08

ZL-16® Roof System Installation Guide

As a good installation practice, all roof installers should carry approved oversized screws. Upon stripping or breaking a screw, the screw must be immediately removed and replaced with the appropriate oversized screw. Do not defer the screw replacement to be remembered and fixed later, or to be found by the clean-up crew. The majority of such screws will be overlooked until the customer complains of leakage.

The following fastener replacement should be used on “over-turned” fasteners.

OVER-TURNED

⑤ 1/4 x 1 1/4” self-drilling screw (3228105)

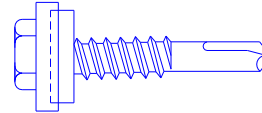

OVER-TURNED

⑫ 1/4” x 3/4” self-drilling screw (3228103)

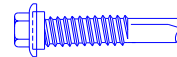

REPLACED BY

⑳ #17 X 1” self-tapping screw (3228126)

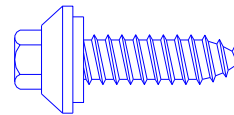

OVER-TURNED

② 1/4” x 3/4” self-drilling screw (3228100)

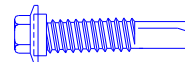

REPLACED BY

#17 x 3/4” self-tapping screw (3228108)

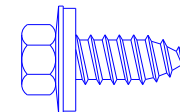

ZL-16® Roof System Installation Guide

5.6 TROUBLE SHOOTING GUIDE

The following information is designed to assist you in correcting problems that may be encountered while installing the self-drilling screws. Listed below are some potential problems, causes and solutions.

If no solution to the problem can be found in the field, contact:

The building manufacturer or Atlas Bolt & Screw Technical Services (800) 321-6977

1. **PROBLEM:** Rounding off hex head.

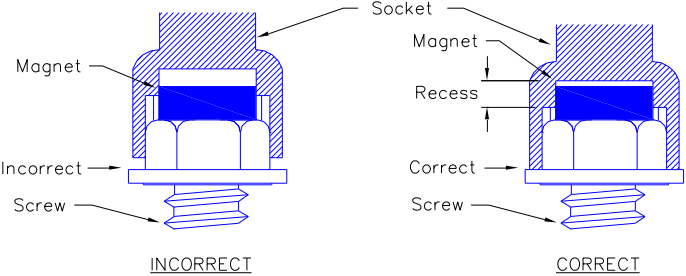
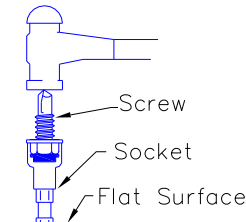
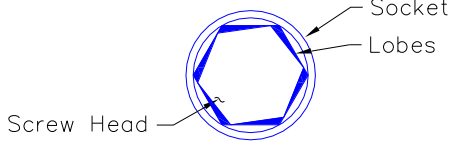
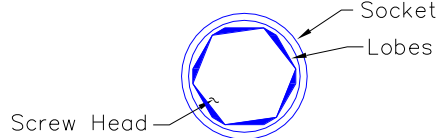
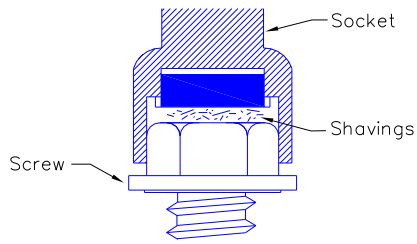
CAUSE	SOLUTION
<p>Improper socket to hex contact.</p>  <p style="text-align: center;">INCORRECT CORRECT</p>	<p>Set the proper magnet depth by using a screw and hammer to drive the magnet further into the recess of the socket.</p> 
<p>Improper engagement of socket to hex head.</p> 	<p>Replace socket with new one which has the new “lobe design” which provides a positive grip while contacting less surface to protect painted heads. Available from building manufacturer.</p> 
<p>Build-up of metal shavings in socket.</p> 	<p>Use a small plug of tape mastic to remove metal shavings.</p>
<p>Socket is worn causing screw to wobble.</p>	<p>Replace socket with new one.</p>
<p>Socket size does not fit approximately to screw head.</p>	<p>Check whether a 5/16” hex or 3/8” hex is being used.</p>

ZL-16® Roof System Installation Guide

2. PROBLEM: Burning off or rounding of drill point.

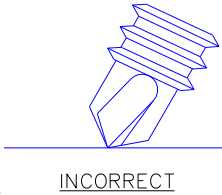
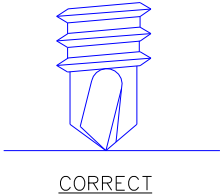
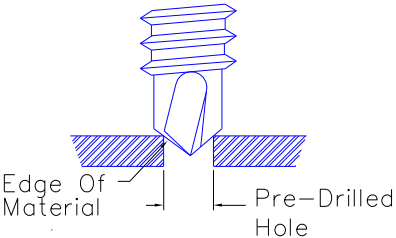
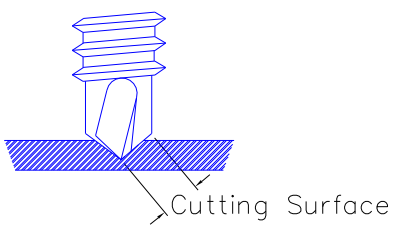
CAUSE	SOLUTION
Forcing screw in by applying too much pressure.	Allow the drill point to do work.
Not keeping fastener perpendicular to surface being drilled.	Reposition screw/screw gun into a vertical position.
 <p style="text-align: center;">INCORRECT</p>	 <p style="text-align: center;">CORRECT</p>
Incorrect drill point of material thickness being drilled.	Check the size/part number of screw being used with erection information supplied with job.
Improper speed (RPM) of screw gun.	Use 1800 RPM screw gun for best results.
Installing a self-drilling screw into a pre-drilled hole. The cutting surface of the screw will be blunted by the edge of the material.	Allow the screw point to drill hole with entire drill point cutting surface.
	

3. PROBLEM: Head separation (Head popping off)

CAUSE	SOLUTION
Incorrect application for screw. Stitch screw used in structural application.	Check the size/part number of screw being used with erection information supplied with job.
Over-torquing the screw.	Use depth sensing nose piece to allow proper seating of fastener.

4. PROBLEM: Head shavings on panel, causing red rust and corrosion.

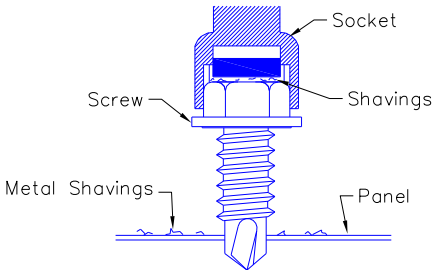
CAUSE	SOLUTION
Steel body screws become magnetized by magnetic socket insert, metal shavings attach to screw and spin onto panel.	Remove build-up of metal shavings in socket so that metal chips will come off the panel and adhere to the socket when screw gun is withdrawn.
The act of installing screws causes metal shavings to lay on surrounding panel surface.	Blow off loose shavings or use soft cloth to gently wipe off shavings from panel surface.
	

5.7 TECHNICAL ASSISTANCE

The information (below) is recommendations from the building manufacturers supplier of its fasteners.



STOP . . . PLEASE READ

RECOMMENDED INSTALLATION FOR SELF-DRILLING TAPPING FASTENERS TO INSURE FASTENER PERFORMANCE

- * Apply with 1800 RPM electric screw gun.
- * Drive socket size must fit appropriately to fastener head.

Socket Types:

1. **Super Star Socket** - Used for long-life non-magnetic screw heads. Can be used with carbon screw to avoid drill chips collecting on magnetic sockets.

Building manufacturers Part No. - 1/4" (3518045) 5/16" (3518046) 3/8" (3518047)
2. **Non-magnetic** - Used by erectors on roofing applications, mainly to avoid drill chips collecting in sockets.
Special Order - 1/4" 5/16" 3/8"

Drilling/Driving fastener must be held perpendicular to the fastening surface.

Self-Drilling fasteners should not be forced in. Allow the drill point to do the work.

- CAUTION -

Over-torquing may result in fastener separation/failure (head popping off).
Care should be exercised during installation.
Torque of 30-60 in. lbs. Based on fastener size and application.

FOR APPLICATION SUPPORT, CONTACT:
ATLAS BOLT & SCREW TECHNICAL SERVICES (800) 321-6977

- * 1800 RPM screw guns and sockets are available at your local tool house or from:
Dynamic Fasteners 1-800-821-5448

5.8 FIELD CUTTING PANELS AND FLASHINGS

A. ABRASIVE SAW PROBLEMS

Abrasive saws (circular saws with friction disks) are not recommended for cutting roof panels or flashing. Abrasive saws create high heat that may burn away the protective cladding from the panel edge, causing the edge to rust.

Also, abrasive saw dust contains fine, hot steel particles, which accumulate on panel and flashing surfaces where they rust and can cause staining and rusting of those surfaces.

Rust caused by abrasive saw damage or abrasive dust particles may be excluded from warranty claims.

B. SHEARING METHODS

It is recommended that panels and flashing be cut with shears to provide a clean, undamaged cut. On shear cut edges, the protective cladding extends to the edge of the cut and is often wiped over the edge to further protect the base metal. Whenever possible, fit the material so that the factory cut edge is exposed and the field cut edge is covered.

When field cutting complex shapes, it is usually easier to cut out a 1" wide strip using both left and right hand shears. The 1" cutout provides clearance to smoothly cut the flats and the clearance to work the shears around tight corners.

When making repetitive cuts (such as cutting panels at a hip condition) it is recommended that a template be made from a piece of drop-off panel or flash to provide fast and accurate marking of the field cut. When using panel material for the template, cut off the top portion of the panel ribs so that the template is easily laid onto the panel being marked.

C. MARKING PANELS

Avoid marking the panels for cutting, etc., in a manner that will leave visible markings stains, etc., on the finished roof surface. Use chalk or felt tip ink markers. **Do not use graphite (lead) pencils on unpainted panel surfaces**, the graphite can cause rusting of the surface.

D. CLEANING METAL CHIPS FROM PANELS

The act of installing self-drilling screws can produce hot metal chips on painted or bare panel surfaces that can literally melt into the panel coating causing them to become adhered to the panel. If these panels are not cleaned immediately, the potential for red rust to deface the panel is almost certain. Blow off loose shavings or use soft cloth to gently wipe off shavings from panel.

5.9 PROTECT ROOF PANELS FROM TRACKING

Construction sites generate steel particles on the ground which the construction crew can track on to the roof surface thru foot traffic. The panel surface can become scratched or marred when the soles of shoes grind soil on steel debris into the panel surface causing steel debris rust staining. One solution is for roofing worker not to switch to the ground and back, workers on the ground should send up all materials needed rather than the roof crew retrieving them. Prevention of steel debris staining is the responsibility of the installer clean all debris off the panels.

ZL-16® Roof System Installation Guide

5.10 TOUCH-UP PAINT

With continued improvements to painted material applications and color matching methods via paint retailers, scanning a color sample is one of the fastest ways to arrive at the correct matched touch-up paint color for Behlen Building Systems sheeting or trim.

Be certain to request an appropriate high performance acrylic / direct-to-metal base for the color match paint. A Sherwin Williams recommended base noted below. Also indicate to your paint retailer that the touch-up paint will be applied to either a Fluropon 70% Kynar or a siliconized polyester finish. Reference your Behlen Buildings Systems drawings cover page for color name and cross reference with your Behlen color chart as necessary to confirm finish type. Note, for a proper color scan and match, the paint sample must physically be a metal sample of painted material. **DO NOT USE** the Behlen color chart for scanning paint color match.

If the local retailer is a Valspar/Sherwin Williams dealer, an alternate way of arriving at a color match other than scanning can be achieved as follows: Use the Valspar / Sherwin Williams Codes noted below and advise paint retailer of your SHER-COLOR request utilizing the appropriate base option. These bases can be tinted to light and dark colors. Copies of these base specifications noted below.

USE SHER-CRYL HPA (HIGH PERFORMANCE ACRYLIC) or PRO INDUSTRIAL DTM ACRYLIC SEMIGLOSS.

Valspar/Sherwin Williams Fluropon 70% Kynar Colors Only

Charcoal (432R1065)	Natural Evergreen (435RZ263)	Patrician Bronze (437R813)
Regal Blue (436RZ1100)	Regal White (431A886)	Surrey Beige (433B365)
Ultra Brite Red (434A986)		

If the local retailer is not a Valspar / Sherwin William affiliate or the color you are trying to match is not available with an SW paint Kynar color code, please have them scan your metal paint sample to arrive at appropriate color formula. Feel free to share with the retailer the Sherwin Williams recommended bases (specifications attached) for use in arriving at a comparable/equivalent type for the brand paint your retailer offers.

GENERAL NOTES: Touch-up paint should be use sparingly and only to cover up areas where the paint has been removed. Areas to be touched up should be wiped with diluted mineral spirits to remove dirt, wax and other contaminants then lightly sanded by using 3M block (medium grit) to roughen the painted surface adjacent to the scratched area before colored touch-up paint is applied.

Aerosol or spray applications are not recommended for blemish or scratch repairs. The best tool for this type of repair is a high quality small bristle or foam brush.

SPECIAL NOTE: Touch-up paints are an air-dry system and application unlike the original color application to the base metal. As such, differential fading and/or color mismatch can develop over long periods of time due to general weathering and UV exposure of the touch-up area compared to the balance of the painted panel surface. A re-touch of the area may be required based on a current color match at that time.

ZL-16® Roof System Installation Guide

5.11 INSULATION AND THERMAL BLOCK COMBINATIONS

The building manufacturer recommends that insulation be used in all standing seam roof applications to avoid problems with condensation and to provide a buffer between the panel and the purlins to eliminate noise and possible damage due to metal-to-metal contact, plus reducing panel modularity problems during installation.

Two clip heights are available (short and tall) with each clip accommodating a range of blanket insulation thicknesses with the (tall) clip also accommodating 3/8", 5/8" or 1" thick thermal blocks.

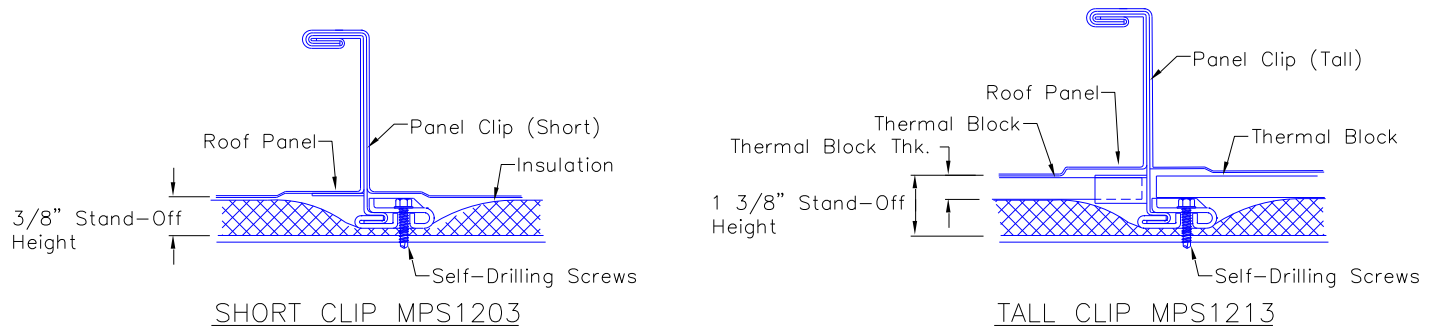

The building manufacturer recommends that the standing seam roof system be installed with a minimum 1 1/2" blanket insulation between the panel and the panel bearing surface (purlin, bar joist, etc...). Below is a chart with various insulation thicknesses and thermal block combinations.

PANEL CLIP		STAND-OFF HEIGHT	INSULATING MATERIAL BETWEEN PANEL AND BEARING SURFACE (SEE NOTE #1 BELOW)
HGHT.	NO.		
SHORT	MPS1203	3/8"	1 1/2" Min. - 4" Max. Blanket - No Thermal Block
TALL	MPS1213	1 3/8"	3" Max. Blanket - 1" Thk. Thermal Block
			Greater Than 3" to 5" Max. Blanket - 5/8" Thk. Thermal Block
			Greater Than 5" to 6" Max. Blanket - 3/8" Thk. Thermal Block

Note #1

These recommendations are based on the assumption that 1" of 6 lb density insulation can be compressed to 1/8" over a 2 3/4" purlin flange.

The building manufacturer can supply a 1/2" x 1" self-adhesive foam tape for limited applications such as (canopies, etc..) when included as part of the building order. Used only with the "short" panel clip.

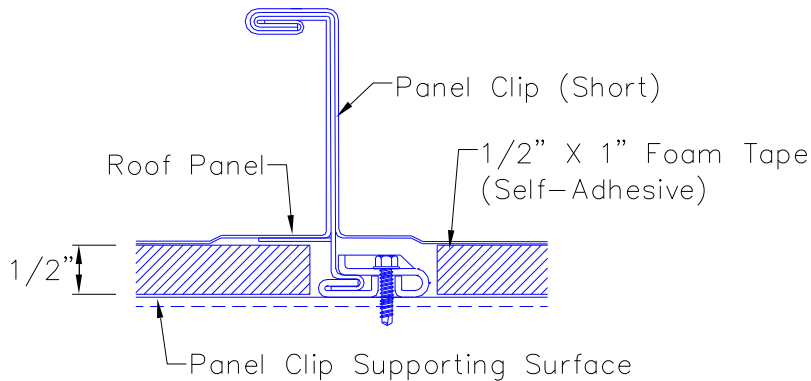

ZL-16® Roof System Installation Guide

When the “Fixed” panel clip having a 0” stand-off height is used over a wood deck, no insulation can be placed between the roof panel and the deck.

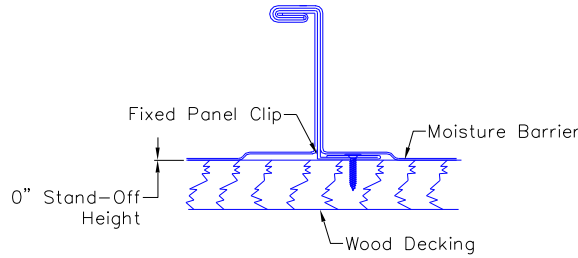

6 ROOF PANEL LAYOUT

6.1 PANEL DESCRIPTION AND NOMENCLATURE

Throughout the manual, references to the panel will be made using the terms shown below. The minor striations in the flat area of the panel will be standard on all panels, they may not be shown in all details for the sake of clarity.

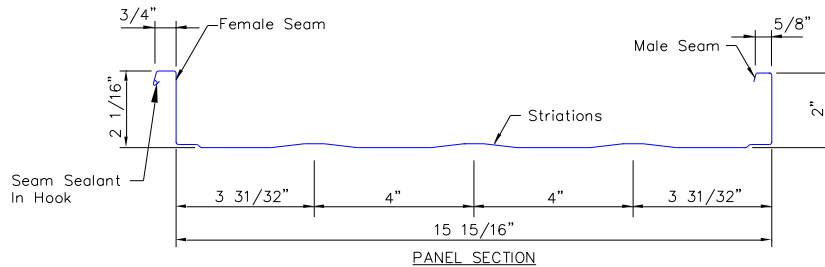
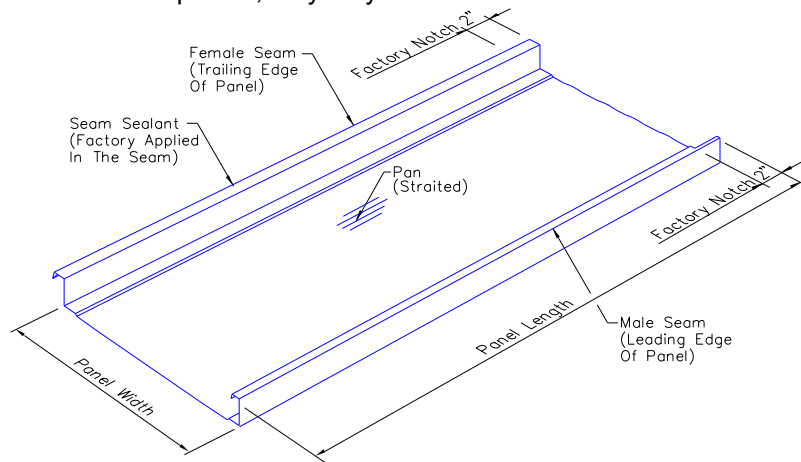

6.2 SHEETING DIRECTION AND MODULARITY

This roof system is designed to be installed in a left-to-right direction, there may be roof conditions which require a different sheeting direction. Check the erection drawings to determine if a different sheeting direction is required. Throughout these instructions the roof sheeting installation will be shown with a (left to right) sheeting direction.

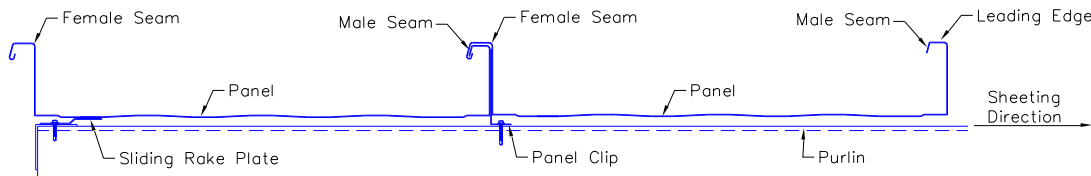

The leading edge of the roof panel is the edge towards the sheeting direction. On the roof panel, the male seam is always the leading edge. Before loading the panels onto the roof structurals, orient the panels so that the male seam is the leading edge.

ZL-16® Roof System Installation Guide

A three step process should be used to engage panel seams during erection.

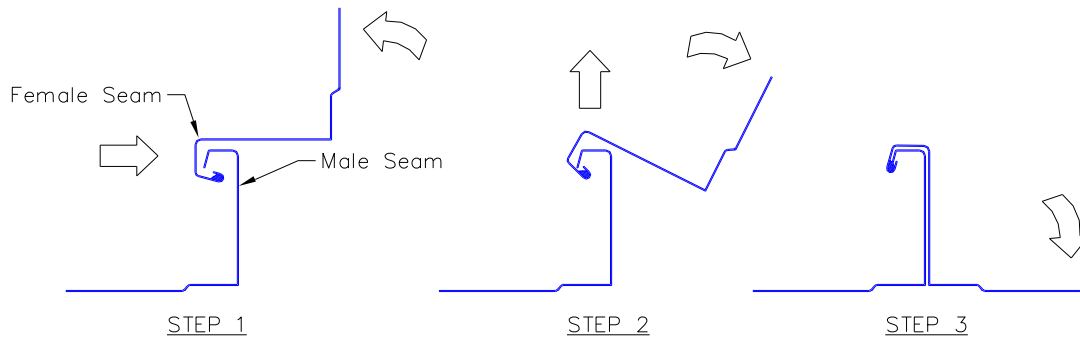

- STEP 1**
1. Tilt panel 90 degrees to vertical position.
 2. Hook female seam under lip of male seam.

- STEP 2**
1. Lift panel so female hook catches male lip.
 2. Rotate panel down to horizontal position.

- STEP 3**
1. Male lip is fully enclosed and nested in female hook.

CAUTION A false seam may occur where the female lip does not hook the roof panels male lip. False seamed roof panels cannot provide their designed loads and maintain the weather tightness resistance.

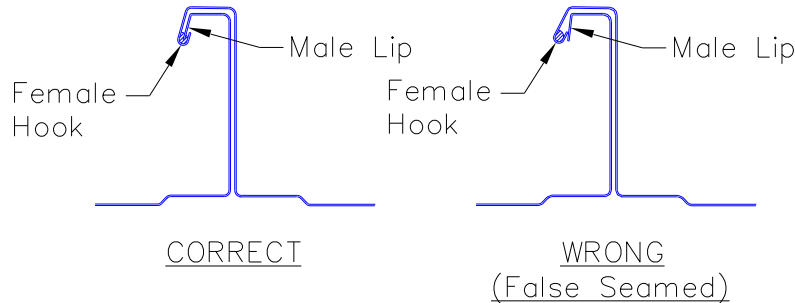

The recommended installation sequence is to complete each panel run from eave to ridge before starting the next panel run.

To maintain roof panel modularity, it is necessary to install “end dams” in the previous panel run. If end dams are not installed in the previous panel run it will be difficult to hold modularity and may require a significant amount of field rework when installing end dams later on.

This sequence will help ensure straight runs and allow the insulation to be installed immediately ahead of each panel run.

During installation of the roof, considerations must be made for maintaining panel modularity so that the roof panel sidelap and seam can be properly assembled, the proper roof coverage can be obtained, and the standard perimeter parts will fit properly without necessity of field modifications or reordering of parts, etc.

Caution: Failure to maintain panel coverage width within the specified tolerance can cause faulty roof panel seams which can result in seaming difficulty or in severe cases reduction in roof performance specifications.

The panels must be held to the width dimension of the panel as designated on the erection drawings within a 1/8” width tolerance per panel. The accumulated coverage (start panel to finish panel) tolerance is determined by the ability to keep the panels parallel and to correctly fit and assemble the finish rake condition.

If the roof has conditions such as fixed location penetrations, parapets, fire walls, etc., the accumulated panel coverage may require tighter tolerances for proper fit-up and weather tightness of the roof.

ZL-16® Roof System Installation Guide

6.3 PANEL LAYOUT, START DIMENSIONS AND CHECKING FOR COVERAGE

Recommended for all roofs, but a must for large or complex roofs, is to make a layout of the actual structure (field measured as described in section 3.3) so that the roof panel start and stop dimensions can be laid out to accommodate any structural misalignments.

Unless noted otherwise on the erection drawings the location of the roof panels along the roof surface will be based on the following.

- A. Buildings whose roof surface length is some multiple of 1'-4" will have the start panel seam and the finish panel seam located with a 0" START DIMENSION.

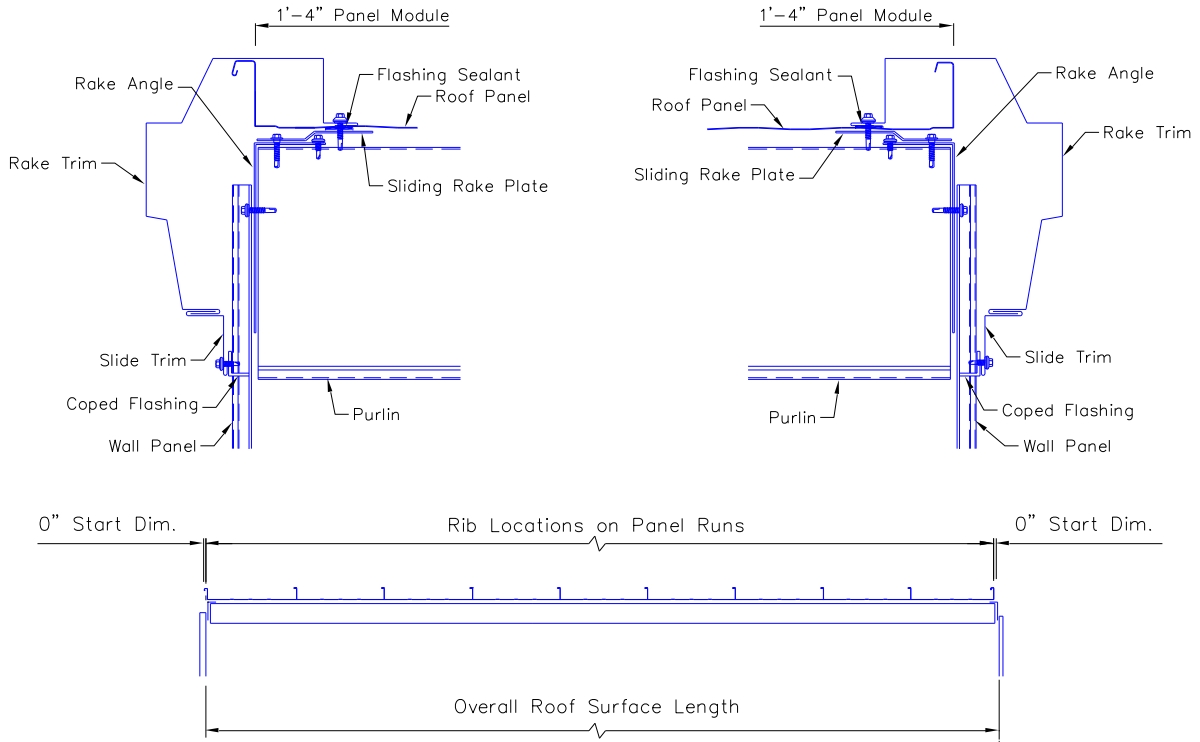

- B. Buildings whose roof surface length is "NOT" a multiple of 1'-4" can have equal START DIMENSIONS on each end.

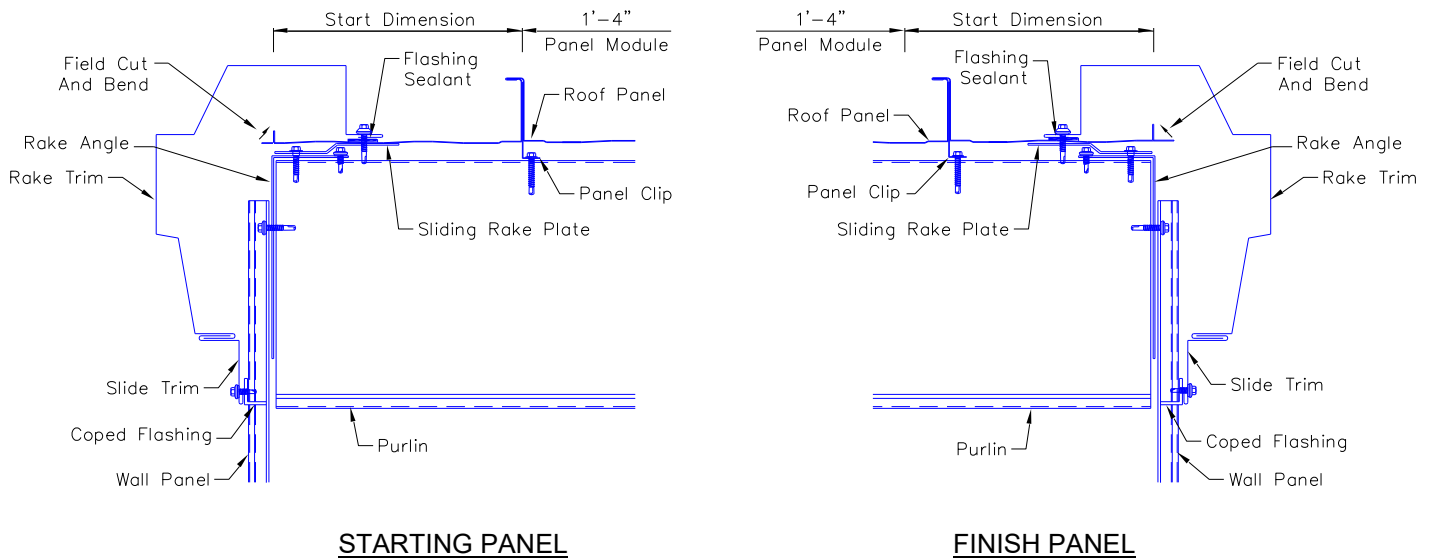

ZL-16® Roof System Installation Guide

Equal “start dimensions” are based on “centering” the panels on the overall roof surface length “as shown below” requiring the field cutting of the starting and finishing panels. Always check the erection drawings as some jobs may require “Unequal” start dimensions.

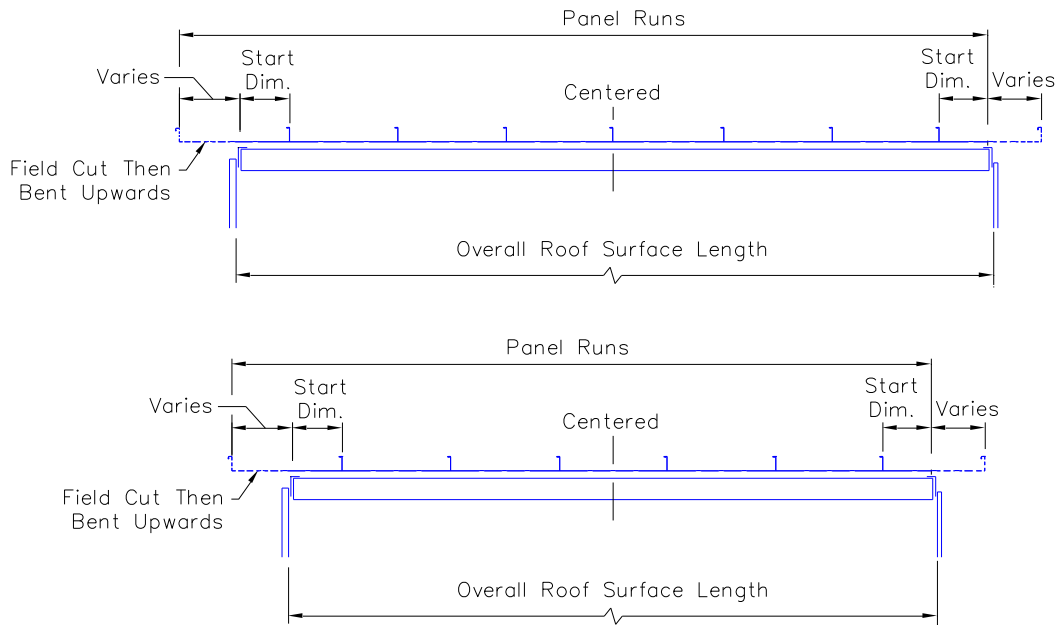

When the optimal start and finish dimensions are determined, a string line should be set to precisely locate the leading edge of the start panel. After the start panel is secured and engaged with the next panel, the start panel seam will be the reference line for checking accumulated panel coverage.

Panel coverage is always checked at the eave, ridge, and end splices so that non-parallel seam (or dogleg) conditions can be detected and corrected before they become objectionable. The coverage check should be done with a measuring tape held taut and measured to the same side of the seam and always parallel to the eave to prevent any measuring error.

Every four to six panel runs should be checked for panel modularity. This will assure that the panels are maintaining a straight line and proper coverage is being maintained. If the panels are off module, they should be corrected by equal adjustments of the next four to six panel runs.

6.4 APPEARANCE CONSIDERATIONS

Although the above stated coverage tolerance will provide for reasonable ease of installation and water tightness, such visible conditions as non-parallel panel seams, dogleg of the panel seam at the end splices, non-parallel finish panel width, and mismatch of panel seams across the ridge, may be objectionable and should be confirmed with the customer before continuing roof installation.

ZL-16® Roof System Installation Guide

7 INSPECTION OF ROOF ASSEMBLY DURING INSTALLATION

7.1 IMPORTANCE OF INSPECTION

During the roof installation, all areas of the roof system assembly must be frequently inspected to ensure the correct assembly in accordance with the erection drawings and this installation guide.

Failure to assemble the roof system correctly will result in roof performance problems that may require costly corrective work, roof replacement and performance and damage claims etc. Also, incorrect installation may void the performance and material warranties.

7.2 INSPECTION LIST

A. ERECTION DRAWINGS

Check that the erection drawings are available at the job site and have been reviewed for difference with the actual job conditions and differences with the installation guide. Also, confirm that the drawings are the latest issue with the latest revisions and additions.

B. ROOF LAYOUTS

Check that the roof start and finish dimensions have been correctly determined based on the erection drawings and the actual structural conditions.

C. BEFORE INSTALLING ROOF PANELS

Check that the structural misalignments were corrected in accordance with Section 3.0 of this installation guide.

Check that the correct eave and rake plates and eave trim are in place before installing the roof panels.

Check that the roof panel elevation provided by the panel clip height and insulation system matches the eave and rake plate elevation.

D. PANEL LENGTH

Check that the installed roof panels have the correct overhang at the eave and endlaps and have the correct hold back at the ridge or high eave, in accordance with the erection drawing.

E. EAVE SEAL

Check that the eave sealant is in the correct position on top of the eave trim and that the eave pigtail sealant is correctly placed. Check that the eave fasteners penetrate the center of the eave sealant and into the eave plate. Check that the fasteners are not loose or stripped.

Check that the eave sealant is in complete contact with the roof panel and eave trim without any voids or gaps. Confirm that the roof panel and eave trim are clean and dry during installation and that the sealant is not wet or otherwise contaminated.

F. ENDLAP SEAL

Check that the roof panel endlaps are correctly assembled and that the lapping panels are tightly nested without visible gaps.

Check that the sealant is in the correct position and is in complete contact with the lapped panels without any voids or gaps, especially at the radius between the panel flat and the vertical legs of the panel. Confirm that the panels are clean and dry during installation and that the sealant is not wet or otherwise contaminated.

Check that the pigtail sealant is in the correct position and seals the endlap seam notches.

Check that the endlap fasteners penetrate through the center of the sealant and into the back-up channel. Check that the fasteners are not loose or stripped.

Check that the endlap assembly is not bowed down causing water ponding and debris accumulations.

ZL-16® Roof System Installation Guide

G. RIDGE SEAL

Check that the end dam assembly is correctly assembled.

Check that the sealant is in the correct position and is in complete contact with the end dam and the roof panel without any voids or gaps. Confirm that the end dams and roof panels are clean and dry during installation and the sealant is not wet or contaminated.

Check that the end dam fasteners penetrate through the center of the sealant and into the back-up channel. Check that the fasteners are not loose or stripped.

Check that the tube sealant is installed along the back of the end dam as necessary to seal any voids around the panel seam area.

H. RAKE SEAL

Check that the rake trim is correctly assembled with the rake trim splices correctly oriented for downhill watershed.

If there are roof panel endlaps, check that the endlap sealant contacts the rake trim sealant or that a pigtail sealant is applied for that purpose.

Check that the sealant is in the correct position above the roof panel.

Check that the rake trim sets fully on the sealant and that the sealant is in complete contact with the roof panel and the trim without any voids or gaps. Confirm that the roof panel and trim are clean and dry during installation and that the sealant was not wet or contaminated.

Check that the rake trim fasteners penetrate the center of the sealant and into the rake plate. Check that the fasteners are not loose or stripped.

I. PANEL CLIP ATTACHMENT

Check that the panel clips are correctly fitted to the panel without any distortion or damage of the clip tab. On panel clips, check that the clip tab is centered on the clip base between the centering tabs.

Check that the clips are located along each panel sidelap at each roof structural or at the locations specified on the erection drawings.

Check that the panel clip fasteners are of the type, size, length, finish and quantity-per-clip as specified on the erection drawings.

Check that the panel clip fasteners are not loose or stripped. In the case of multi-layered construction, verify that the fasteners penetrated and engaged the specified structural member.

J. SIDELAP

Check that the panel sidelaps are on module (held to within the 1/16" panel width tolerance) and are assembled so that the male and female panel edges and panel clips are properly nested together prior to seaming.

Check that the full length of each sidelap seam is correctly seamed.

Check that the factory installed sidelap sealant is in the correct position without voids or interruptions and is not damaged, wet or otherwise contaminated.

Check that the panel coverage tolerance does not exceed 1/16" per panel and that the accumulated coverage will allow proper fit and assembly of the end dams and finish rake condition and any other critical fit conditions such as penetrations, parapets, etc.

ZL-16® Roof System Installation Guide

K. FLASHING AND PENETRATIONS

Check that all flashing (including penetrations) are correctly assembled and tightly fitted. Check that the required sealants are correctly positioned and in complete contact with the adjoining surfaces without voids or interruptions. Confirm that the sealants and adjoining surfaces are clean and dry during installation.

Check that the flashing splices are correctly lapped, sealed and fastened.

Check that the flashing is sufficiently pitched to shed water and eliminate ponding areas, especially at the critical splices, endlaps and corners.

Check that the fasteners are of the specified type, size, length, finish and spacing. Check that the fasteners are not loose or stripped. Check that the sealing washers are in full contact with the flashing surface and not distorted, split or otherwise damaged.

Along the rakes, high eave transitions, fixed penetrations, etc., check that the flashing is not constrained and will allow for the roof's expansion/contraction movement.

L. SURFACE CONDITIONS

Damaged roof system surfaces are subject to corrosion and performance problems and may void the material and performance warranties.

Check that the panel and flashing surfaces are not being subjected to abusive conditions such as: careless handling of panels and flashing, excessive roof traffic, abrasive or contaminated footwear, rough handling of materials, tools and equipment, or contact with abrasive materials or residue, etc.

Check that the panel and flashing surfaces are not being subjected to exposed metal objects and materials left on the roof such as: tools, material drop-off, fasteners, wire, staples, drill and nibbler chips, saw and file particles, etc. In the process of rusting, these materials will absorb the panel's protective coating, thus leaving the panels exposed to rusting.

Check that the panels and flashing are not being subjected to long term wet conditions such as: standing water, consistent sources of steam, mist, spray, dripping or runoff, wet debris, wet insulation or other moisture holding material.

Check that the panels and flashing are not subjected to direct contact or runoff from corrosive materials such as: copper pipes and flashing, uncured cement, treated lumber anti-icing chemicals, strong solvents or other corrosive materials.

Check that graphite pencils were not used to mark on unpainted surfaces. The graphite marks can cause rusting.

Check that the roof materials are not subjected to damaging heat such as: cutting torches, abrasive saws, etc.

M. UNSPECIFIED MATERIALS

Use of the wrong materials may cause installation and performance problems and may void the performance and material warranties.

Check that all installed roof system materials, especially sealants and fasteners, are only those which are provided or specified by the building manufacturer for your specific project and are used only as specified on the erection drawings and this installation guide.

8 STANDARD PARTS

8.1 GENERAL

The following details provide a basic description and graphic illustrations of the standard roof assembly parts. The purpose of these details is to assist the erector in the correct selection and identification of parts.

Because of the many variations in conditions, it is important that you review the job conditions to identify the specific parts required for your job.

Review the erection drawings for any special parts or parts which are different from the standard parts shown in these details. If differences exist, the erection drawings will have preference.

For proper fit-up, sealing and fastening, and to help ensure the roof assembly's weathertightness, structural capability, durability and appearance, the correct parts must be used. Do not use parts other than those specified on the erection drawings.

8/29/08

ZL-16® Roof System Installation Guide

8.2 ROOF COMPONENTS, EAVE AND RAKE PLATES

ROOF PANEL (16" wide panel)

- 24 gauge precoated or galvalume material
- Roof color
- Striated pan
- Factory notched for endlap

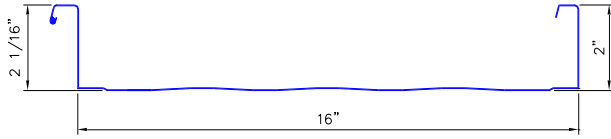

END DAM (for 16" wide panel)

- 24 gauge precoated or galvalume material
- Roof color
- Factory punched holes

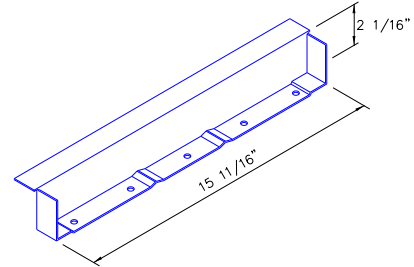

Part No. MT335

Fixed Clip (for 0" stand-off)

- 20 ga. Galvanized Steel

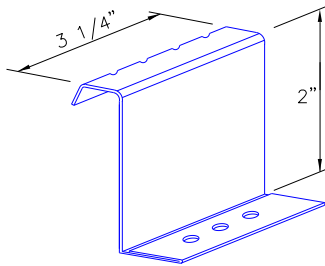

Part No. FC 11200

Back-up Channel

- 16 gauge Galvanized Steel
- Factory punched & swegged

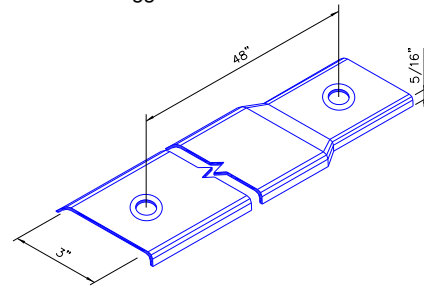

Part No. MC 64

Floating Clip (for 1 3/8" stand-off)

- 20 ga. Galvanized Steel, Tab
- 16 ga. Galvanized Steel, Base

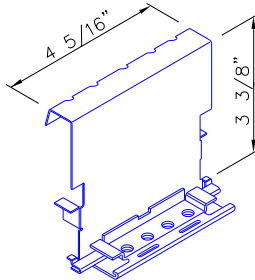

Part No. MPS 1213

Thermal Block

- Extruded Polystyrene Foam
- 3/8", 5/8" or 1" Thick

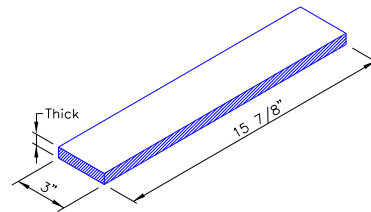

Part No. 2308028 (3/8" Thick)
 Part No. 2308029 (5/8" Thick)
 Part No. 2308030 (1" thick)

FLOATING CLIP (for 3/8" stand-off)

- 20 ga. Galvanized Steel, Tab
- 16 ga. Galvanized Steel, Base

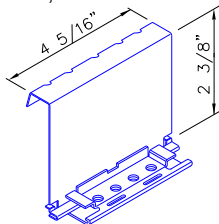

Part No. MPS1203

Cinch Strap (optional)

- 18 gauge stainless Steel
- Factory punched holes

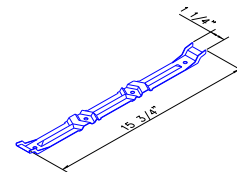

Part No. 3018194

ZL-16® Roof System Installation Guide

EAVE PLATE (for 3/8" stand-off)

- 16 ga. 55 ksi Primed Steel
- 12'-0" length
- Factory punched holes at 12" ctrs.

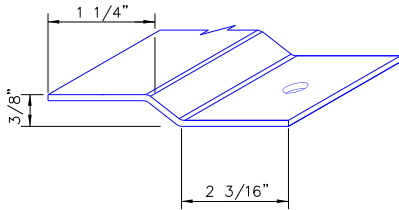

Part No. MP254

SLIDING RAKE PLATE (for 3/8" stand-off)

- 16 ga. 55 ksi Primed Steel
- 12'-0" length
- Factory punched slots at 24" ctrs.

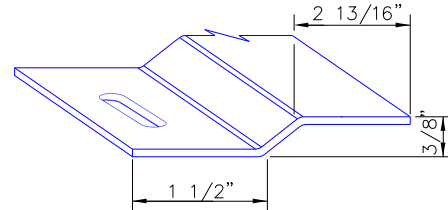

Part No. MP260

EAVE PLATE (for 1 3/8" stand-off)

- 16 ga., 55 ksi Primed Steel
- 12'-0" length
- Factory punched holes at 12" ctrs.

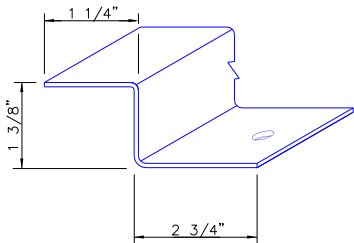

Part No. MP255

SLIDING RAKE PLATE (for 1 3/8" stand-off)

- 16 ga., 55 ksi Primed Steel
- 12'-0" length
- Factory punched slots at 24" ctrs.

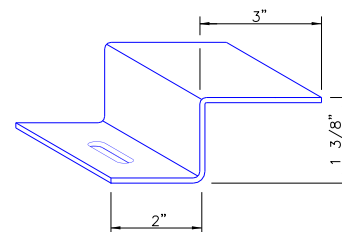

Part No. MP261

EAVE PLATE (for 0" stand-off)

- 16 ga., 55 ksi Primed Steel
- 12'-0" length
- Factory punched holes at staggered 6" spacing

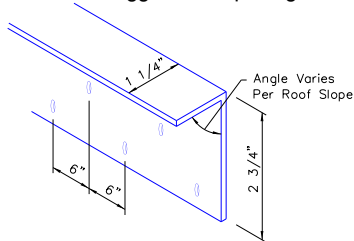

- Part No. AG96 (1/4; 12 to 1/2; 12 roof slope)
- Part No. AG91 (3/4; 12 to 1:12 roof slope)
- Part No. AG92 (2:12 roof slope)
- Part No. AG97 (3:12 roof slope)
- Part No. AG93 (4:12 roof slope)

FIXED RAKE PLATE (for 0" stand-off)

- 16 ga., 55 ksi Primed Steel
- 12'-0" length
- Factory punched holes at staggered 6" spacing

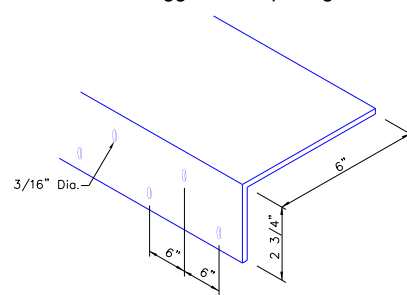

Part No. MP293

INSIDE ANGLE (for 0" Stand-off)

- 16 ga. 55 ksi Primed Steel
- 15'-0" length

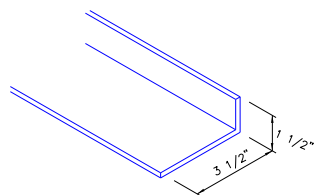

Part No. AG79DG

ZL-16® Roof System Installation Guide

8.3 ROOF TRIMS

END CAP

- 26 gauge precoated material
- Trim color
- At low eave corners

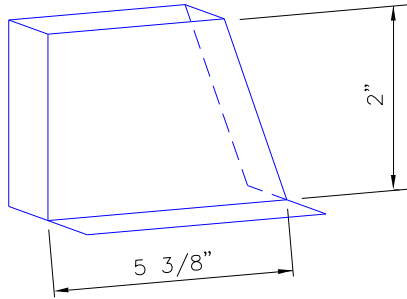

Part No. TR83 (RH Shown) TR84 (LH)

EAVE TRIM

- 26 gauge precoated material
- Trim color
- Length 20'-6"
- Bent two at a time

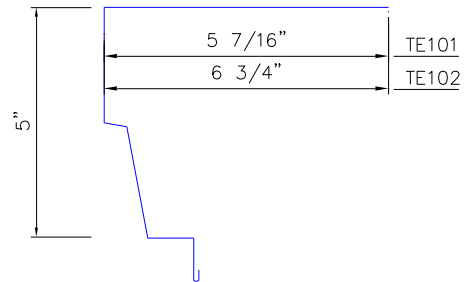

Part No. TE101-20 Roof Slope 1 1/2:12 or Less
Part No. TE102-20 Roof Slope 1 9/16 thru 4:12

HIGH EAVE TRIM

- 26 gauge precoated material
- Trim color
- Length 20'-6"

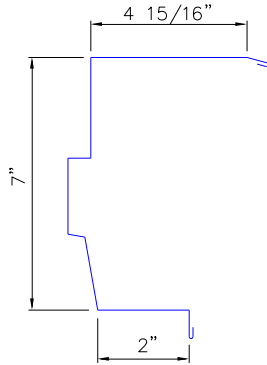

Part No. TE105-20 Roof slope 2 1/2:12 or less

CORNER BOX CAP

- 26 gauge precoated material
- Trim color
- At high eave corners

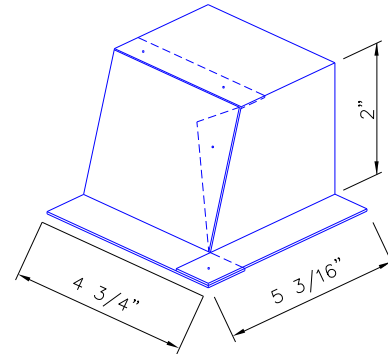

Part No. TR85 (R.H. Shown) TR86 (L.H.)

EAVE FLASHING

- 26 gauge precoated material
- Trim color
- Length 20'-6"
- Bent two at a time

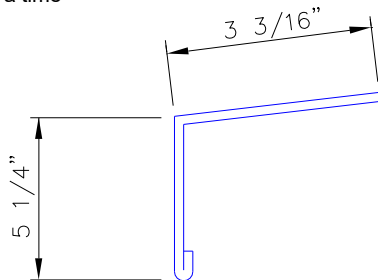

Part No. TE99-20 Roof Slope 1 1/2:12 or Less
Part No. TE100-20 Roof Slope 1 9/16 thru 4:12

BIRD STOP

- 26 gauge precoated material
- Trim color
- At ends of eave flashing run
- Roof slopes to 4:12

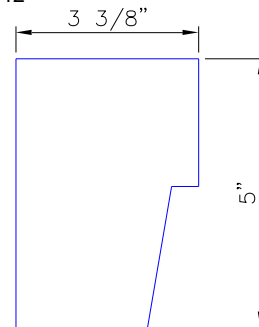

Part No. TE51-1 (RH shown) TE54-1 (LH)

8/29/08

ZL-16® Roof System Installation Guide

8.4 GUTTER COMPONENTS

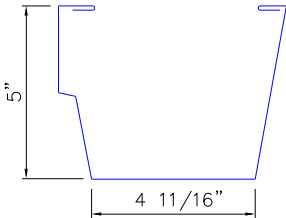
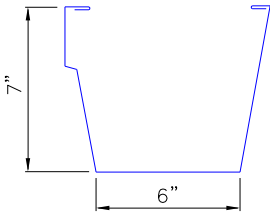
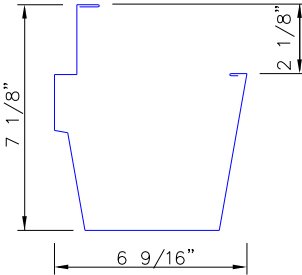
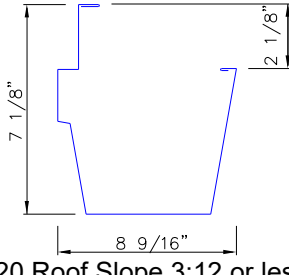
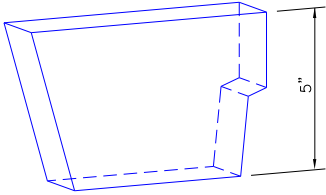
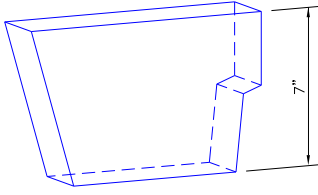
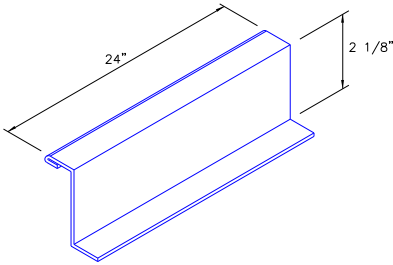
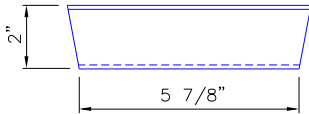
<p>STANDARD GUTTER</p> <ul style="list-style-type: none"> • 26 gauge precoated material • Trim color • Length 20'-6"  <p>Part No. TE11-20 Roof slope 3:12 or less</p>	<p>HIGH CAPACITY GUTTER</p> <ul style="list-style-type: none"> • 26 gauge precoated material • Trim color • Length 20'-6"  <p>Part No. TE25-20 Roof slope 3:12 or less</p>
<p>RIB CONCEALING GUTTER</p> <ul style="list-style-type: none"> • 26 gauge precoated material • Trim color • Length 20'-6"  <p>Part No. TE107-20 Roof slope 3:12 or less</p>	<p>RIB CONCEALING (HIGH CAPACITY) GUTTER</p> <ul style="list-style-type: none"> • 26 gauge precoated material • Trim color • Length 20'-6"  <p>Part No. TE109-20 Roof Slope 3:12 or less</p>
<p>GUTTER END CAP</p> <ul style="list-style-type: none"> • 26 gauge precoated material • Trim color • Used at ends of standard gutter and rib concealing gutter (above)  <p>Part No. TE68 (Left Hand) TE69 (Right Hand)</p>	<p>GUTTER END CAP</p> <ul style="list-style-type: none"> • 26 gauge precoated material • Trim color • Used at ends of high capacity gutter and rib concealing high capacity gutter (above)  <p>Part No. TE72 (Left Hand) TE73 (Right Hand)</p>
<p>RIB CONCEALING CORNER TRIM</p> <ul style="list-style-type: none"> • 26 gauge steel • Precoated or Galvalume Finish • Trim color  <p>Part No. TE106</p>	<p>GUTTER STOP</p> <ul style="list-style-type: none"> • 26 gauge precoated material • Trim color • Used at ends of high capacity gutter and rib concealing high capacity gutter (above)  <p>Part No. TE27</p>

ZL-16® Roof System Installation Guide

8.5 GUTTER COMPONENTS

STANDARD GUTTER

- 26 gauge precoated material
- Trim color
- Length 20'-6"

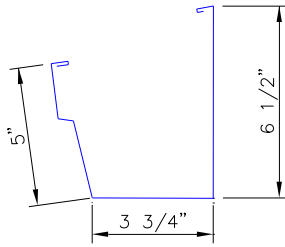

Part No. TE10-20 Roof slope 3 1/16":12 to 4:12

HIGH CAPACITY GUTTER

- 26 gauge precoated material
- Trim color
- Length 20'-6"

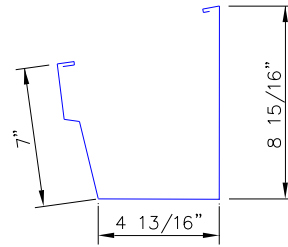

Part No. TE64-20 Roof Slope 3 1/16":12 to 4:12

RIB CONCEALING GUTTER

- 26 gauge precoated material
- Trim color
- Length 20'-6"

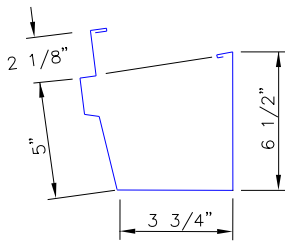

Part No. TE108-20 Roof slope 3 1/16":12 to 4:12

RIB CONCEALING (HIGH CAPACITY) GUTTER

- 26 gauge precoated material
- Trim color
- Length 20'-6"

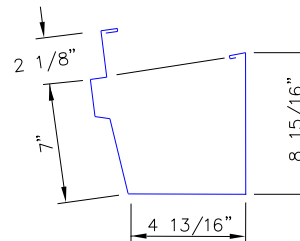

Part No. TE110-20 Roof slope 3 1/16":12 to 4:12

GUTTER END CAP

- 26 gauge precoated material
- Trim color
- Used at ends of standard gutter and rib concealing gutter (above)

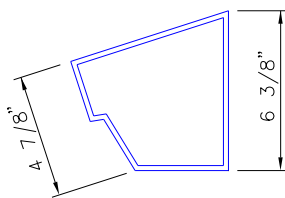

Part No. TE70 (left-hand) shown TE71 (right-hand) similar

GUTTER END CAP

- 26 gauge precoated material
- Trim color
- Used at ends of standard gutter and rib concealing gutter (above)

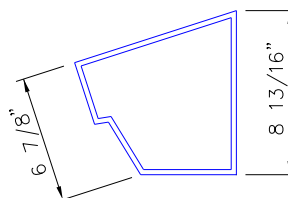

Part No. TE74 (left-hand) shown TE75 (right-hand) similar

GUTTER STOP

- 26 gauge precoated material
- Trim color
- Used at ends of standard gutter and rib concealing gutter (above)

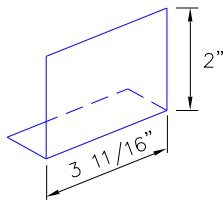

Part No. TE8

GUTTER STOP

- 26 gauge precoated material
- Trim color
- Used at ends of high capacity gutter and rib concealing high capacity gutter (above)

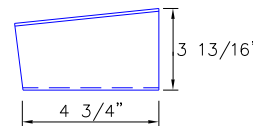

Part No. TE29 (right-hand) shown TE28 (left-hand) similar

ZL-16® Roof System Installation Guide

8.6 RAKE TRIM AND DOWNSPOUT COMPONENTS

GUTTER HANGER

- 18 gauge galvanized or painted
- Roof color

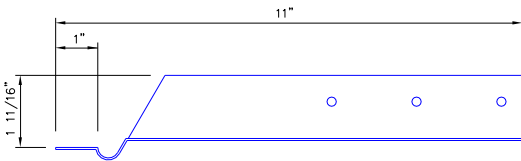

Part No. MS41

GUTTER HANGER

- 18 gauge galvanized or painted
- Roof color

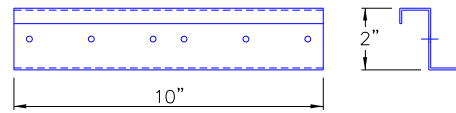

Part No. MZ38

RAKE TRIM

- 26 gauge precoated material
- Trim color
- Length 20'-6"

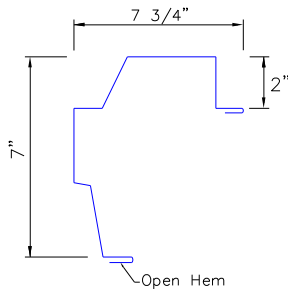

Part No. TR82-20

SLIDE TRIM

- 26 gauge precoated material
- Trim color
- Length 20'-6"

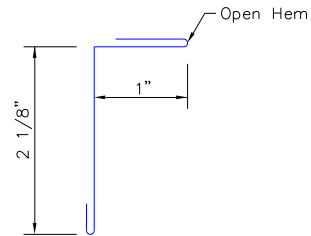

Part No. TR66-20

4" DOWNSPOUT

- 29 gauge precoated material
- Polar White color
- 10 ft. long

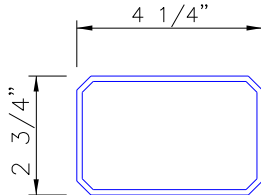

Part No. TM6

5" DOWNSPOUT

- 29 gauge precoated material
- Downspout color
- 10 ft. long

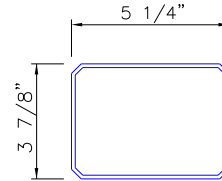

Part No. TM86

4" ELBOW

- 29 gauge precoated material
- White color
- Type "A"

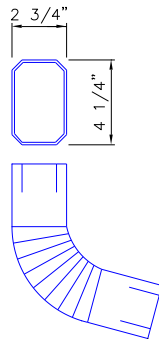

Part No. TM7

5" ELBOW

- 26 gauge precoated material
- Type "A"
- 4 x 5

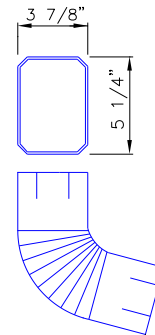

Part No. TM87

ZL-16® Roof System Installation Guide

8.7 CORNER BOXES AND RIDGE COMPONENTS

DOWNPOUT STRAP

- 26 gauge precoated material
- Used with 4" downspout

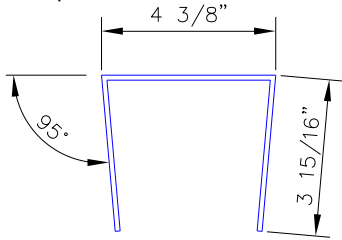

Part No. MS19

DOWNPOUT STRAP

- 26 gauge precoated material
- Used with 5" downspout

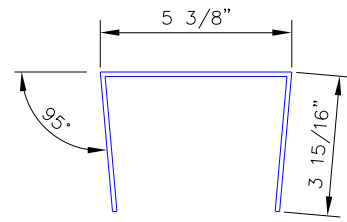

Part No. MS26

OUTSIDE CORNER BOX

- 26 gauge precoated material
- Trim color
- At low eave and high eave corners

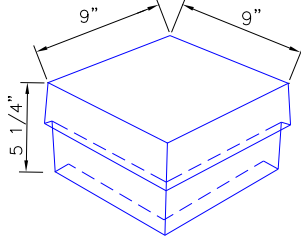

Part No. TE13

INSIDE CORNER BOX

- 26 gauge precoated material
- Trim color

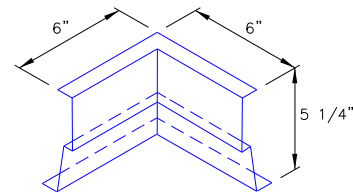

Part No. TE14

RIDGE CAP (see NOTE below)

- 26 gauge precoated or galvalume
- Roof color
- Roof slope 4:12 or less

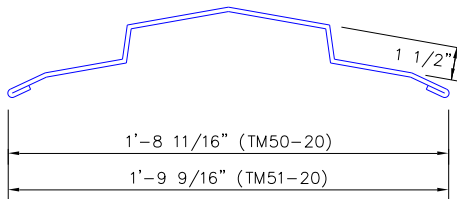

Part No. TM50-20 Roof slope 2:12 or less
Part No. TM51-20 Roof slope 2 1/16:12 thru 4:12

PEAK CINCH STRAP

- 16 gauge galvanized steel
- Roof slope 4:12 or less
- 1" width

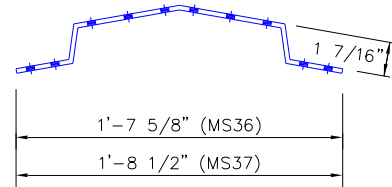

Part No. MS36 Roof slope 2:12 or less
Part No. MS37 Roof slope 2 1/16:12 thru 4:12

FLEXIBLE MEMBRANE

- Black EPDM Material
- 0.045" Thick

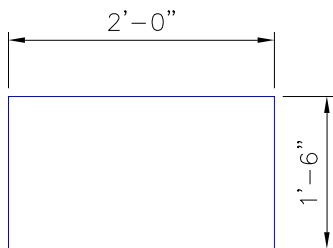

Part No. TM54

CINCH STRAP

- 16 gauge galvanized steel
- 1" width

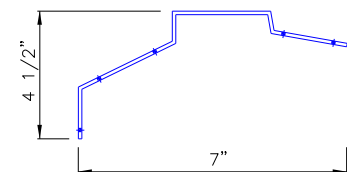

Part No. MS42

Note: When "Pre-Vent" ridge ventilation system is used, see section 11.1 for part replacement.

3/2/09

ZL-16® Roof System Installation Guide

8.8 TRIM AT ENDWALL PEAK

CINCH STRAP (See NOTE below)

- 16 gauge galvanized steel

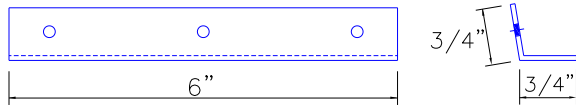

Part No. MS34

PEAK FLASHING ZEE

- 22 gauge galvalume steel

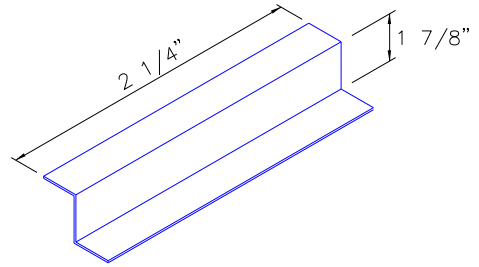

Part No. MZ32

LH PEAK FLASHING

- 26 gauge precoated material
- Trim color

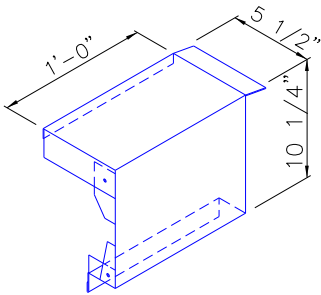

Part No. TR88

RH PEAK FLASHING

- 26 gauge precoated material
- Trim color

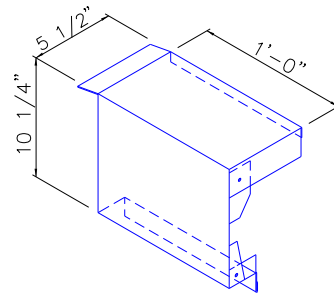

Part No. TR87

SIGN

- 20 gauge porcelain coated material
- White

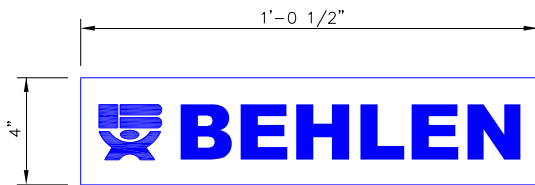

Part No. 16881086 or TR21 (High Eave)

ZL-16® Roof System Installation Guide

8.9 FASTENERS

Fasteners will be identified by a "label" or circle with a numerical number inside of it. These labels and numbers will correspond to the ID number in the FASTENER SCHEDULE in the job erection drawings.

- ② **SCREW 1/4 x 3/4 FL-TP SD WW**
- Self-drilling screw with a flat-top under cut 5/16" hex head and EPDM sealing washer
 - Stitch screw for attaching eave and rake trims to wall surfaces.

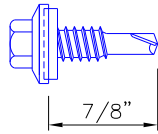

Part No. (Plated) 3228100
Part No. (Colored) 3228100__ (code)

- ③ **SCREW 12 x 1 HWH SD NW**
- Self-drilling screw with a 5/16" hex head and no washer
 - Rake angle to purlin fastener

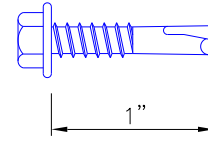

Part No. 3228084

- ⑤ **SCREW 1/4 x 1 1/4 LG-LF SD WW**
- Self-drilling screw with a long-life 5/16" hex head with EPDM sealing washer
 - Structural screw for attaching roof panel to eave plates.
 - Attaching rake trim to sliding rake plate.

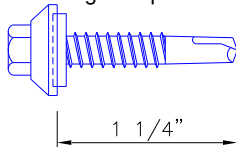

Part No. (Plated) 3228105
Part No. (Colored) 3228105__ (code)

- ⑥ **SCREW 8 x 1/2 HWH SD NW**
- Self-drilling screw with a 1/4" hex head and no washer.
 - Roof trim endlap fastener

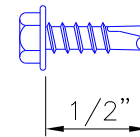

Part No. (Plated) 3228099
Part No. (Colored) 3228099__ (code)

- ⑫ **SCREW 1/4 X 3/4 LG-LF SD WW**
- Self-drilling screw with a long-life 5/16" hex head with EPDM sealing washer
 - Stitch screw for attaching ridge caps to end dams, ridge cap endlaps and (ridge) cinch straps.

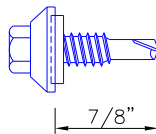

Part No. (Plated) 3228103
Part No. (Colored) 3228103__ (code)

- SCREW 12 x 2 HWH SD #5 PT NW**
- Self-drilling screw with a 5/16" hex head with #5 drill point and no washer
 - Panel clip fastener to bar joist

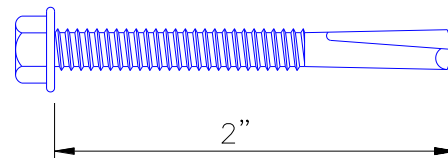

Part No. 3228133

- ⑰ **SCREW 1/4 x 1 1/2 HWH SD NW**
- Self-drilling screw with a 5/16" hex head and no washer
 - Panel clip fastener
 - Eave plate fastener

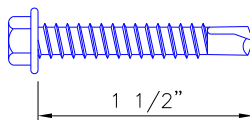

Part No. 3228122

- ⑳ **SCREW 1/4 x 1 1/4 HWH SHOULDER SD NW**
- Self-drilling screw with a 5/16" hex head with shoulder and no washer
 - Sliding rake plate fastener to purlin/rake angle

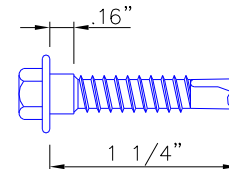

Part No. 3228124

ZL-16® Roof System Installation Guide

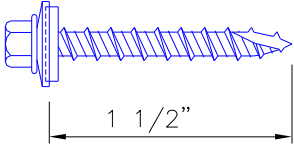
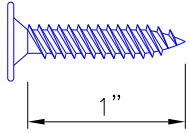
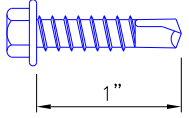
	<p>SCREW 10 x 1 ½ HWH WOODTITE WW</p> <ul style="list-style-type: none"> • Woodtite screw with 1/4" head and type 17 drill point • Fixed eave plate and rake plate • Attachment to wood substructure.  <p>Part No. 3208084</p>
<p>SCREW 10-12x1 WAFER HEAD</p> <ul style="list-style-type: none"> • #2 square drive, wafer head • For fixed panel clip attachment to wood deck.  <p>Part No. 3228139</p>	<p>②⑥ SCREW 1/4X1 HWH SD NW</p> <ul style="list-style-type: none"> • Self-drilling screw with a 5/16" hex head and no washer. • Back-up channel endlaps  <p>Part No. 3228138</p>

8.10 MASTICS

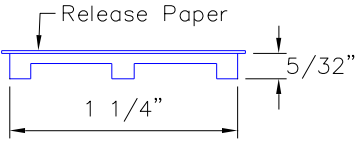
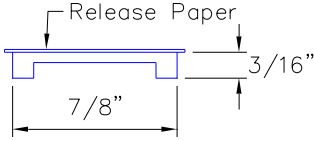
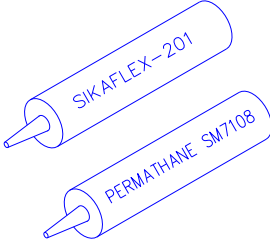
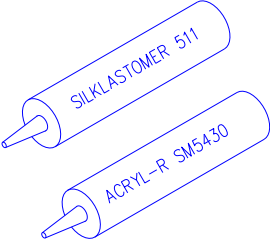
<p>TAPE SEALANT</p> <ul style="list-style-type: none"> • SEALER 5/32 x 1 1/4 x 30' ROLL • Along low eave lines • Along endwall rake trim to panel lap • Roof panel endlaps.  <p>Part No. 3209430</p>	<p>TAPE SEALANT</p> <ul style="list-style-type: none"> • SEALER 3/16 x 7/8 x 40' ROLL • End dams to panel. • Ridge cap to end dam • High eave trim to end dam • At peak or high eave corner  <p>Part No. 3209120</p>
<p>GUN GRADE MASTIC</p> <ul style="list-style-type: none"> • Skinning urethane caulk • Perimeter roof trim endlaps • At corner boxes and endcaps  <p>Part No. 3288023</p>	<p>GUN GRADE MASTIC</p> <ul style="list-style-type: none"> • Non-skinning butyl caulk • At panel endlaps • Along end dams  <p>Part No. 3288028</p>

ZL-16® Roof System Installation Guide

ADHESIVE BACK 1/2 X 1 WEATHERSTRIPPING

- A resilient foam tape (25 ft. roll) to fill void between panel flat and clip supporting surface when no blanket insulation is used.

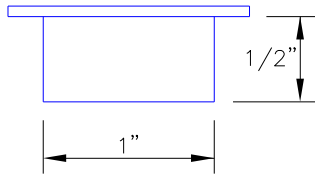

Part No. 3939050

TAPE SEALANT

- SEALER 3/16 x 2 1/2 x 20' ROLL
- Along Hip and Valley Flashings
- Perimeter of Roof Curbs

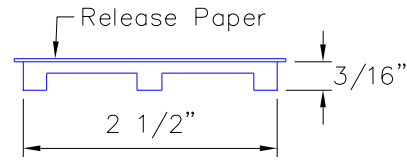

Part No. 3209410

9 ROOF INSTALLATION DETAILS

9.1 GENERAL

The purpose of this information is to instruct the erector in correct and efficient assembly of the roof system. The following details provide graphic illustration of the roof assembly steps for the following building types and/or conditions.

- Installation over wood deck, purlins or bar joists.
- Gabled and single sloped buildings
- Low eave and rakes of lean-to building
- Gutters for roof slopes of 4" to 12" or less
- Roof accessories

Because of the many variations in conditions, it is important that you review the job to identify and isolate the specific installation details required for your job.

Review the erection drawings for differences with these details. If differences exist, the erection drawings have precedence.

These details are arranged in a step-by-step sequence. Following this sequence ensures correct assembly and ensures that the part to be worked on will be readily accessible for the next assembly step.

Do not shortcut these assembly steps without careful consideration of the possibility of incorrect or omitted assembly and the resulting corrective rework.

To minimize confusion, the details are always oriented so that the view is from eave to ridge, with the starting rake at the left and finish rake at the right. Refer to the erection drawings to determine the required sheeting direction and rake conditions.

To help ensure weather tightness, the details emphasize proper fit-up, sealing and fastening. It is most important that only the specified sealants and fasteners be used for each condition and that they be installed correctly as shown on these details and the erection drawings.

Be sure that these critical instructions are reviewed often and the roof assembly is checked at each assembly step.

The preparation for roof panel installation will vary depending on whether the "fixed" panel clips having a 0" stand-off height is being used to fasten the roof panels to a wood deck or the "floating" panel clips with 3/8" or 1 3/8" stand-off heights are being used to fasten the roof panels to secondary structural members such as purlins or bar joists.

ZL-16® Roof System Installation Guide

9.2 PREPARATION FOR ROOF PANEL INSTALLATION OVER A WOOD DECK

The information in this section covers the preparation for installing a roof over a wood deck by the use of “fixed” panel clips having a 0” stand-off height. Fixed panel clips will be a one-piece clip that will not allow the roof panel to move with expansion and contraction.

If the job has been supplied with the floating panel clips that are used to fasten the roof panels to secondary structural members such as purlins, skip this Section 9.2 and see Section 9.3, page 53

9.2.1 OREINTATION VIEW

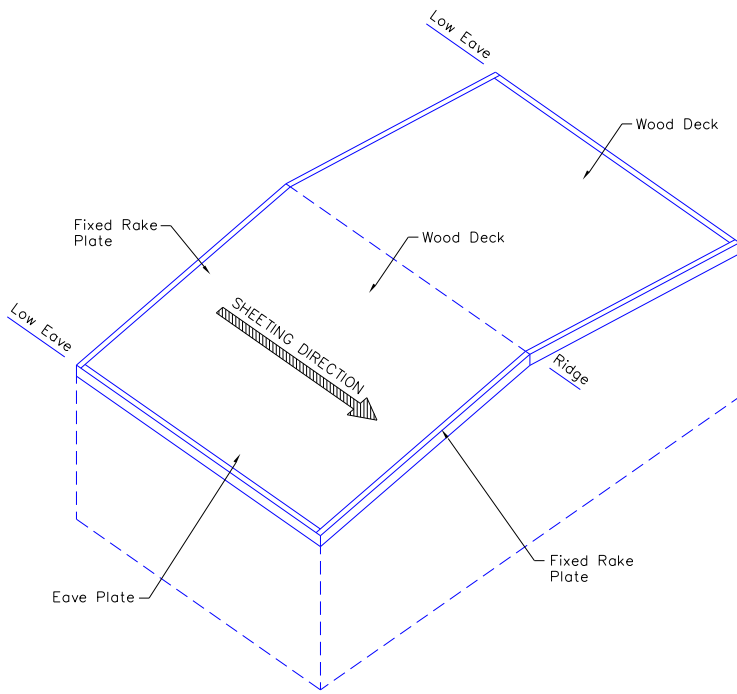

GABLED BLDG.

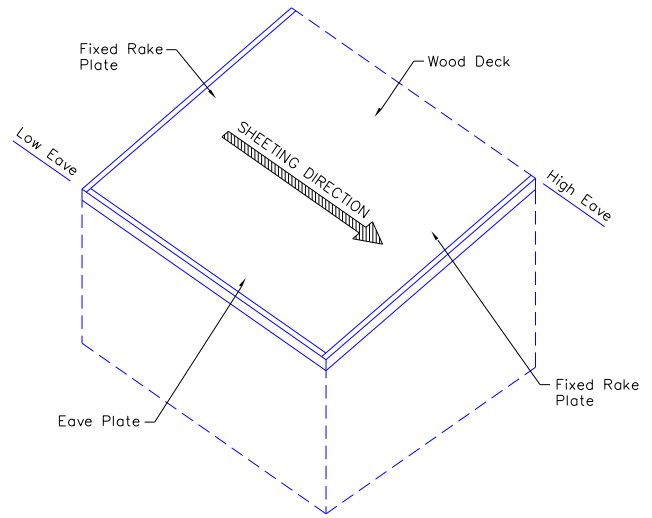

SINGLE SLOPE BLDG.

The details in this section will show the installation of the fixed rake plate along the endwall rake, and along the low eave the eave plate, eave flashing and eave trim. These are parts that must be installed before the roof panel installation can begin.

This view shows the roof system oriented for a left-to-right sheeting direction.

Fixed rake plates are required at both ends of building. Refer to the erection drawings for the required rake conditions.

ZL-16® Roof System Installation Guide

9.2.2 INSTALL EAVE PLATE

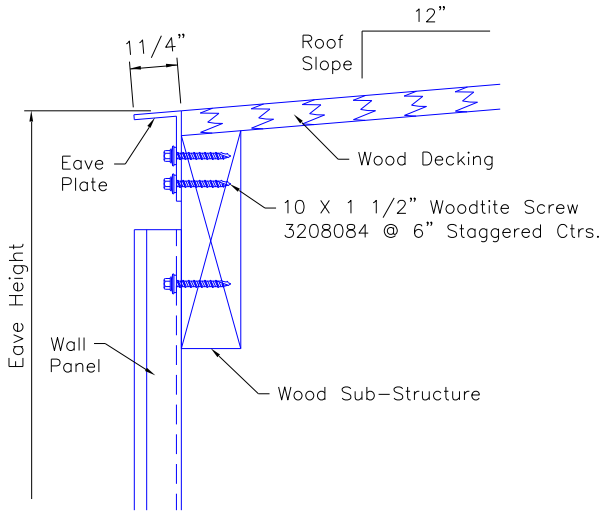

Roof Slope	Part No.
1/4" to 12"	AG 96
1/2" to 12"	AG 96
3/4" to 12"	AG 91
1" to 12"	AG 91
2" to 12"	AG 92
3" to 12"	AG 97
4" to 12"	AG 93
Others	See Plans

The eave plate provides a solid attachment surface for the low eave end of the roof panel. Eave plates should never be placed at the high eave on single slope buildings.

Use applicable part from Table A unless noted otherwise on erection plans. The eave plate must be installed before roof panel installation can begin.

Before installing the eave plate, check that the eave members are in a straight alignment from rake to rake. Shim the eave plate as necessary to provide an even level line along the eave.

Use 10x1 1/2" woodtite screws at a "staggered" 6" centers to attach the eave plate to the wood substructure. Install the starting and finish ends of the eave plates flush with the endwall rake.

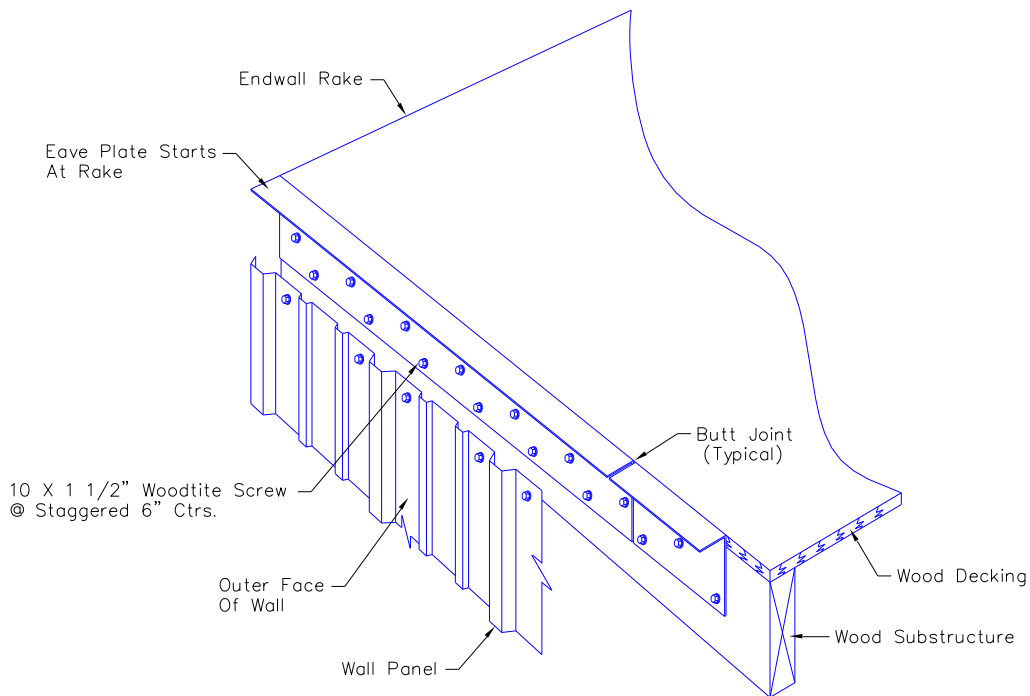

ZL-16® Roof System Installation Guide

9.2.3 INSTALL FIXED RAKE PLATE

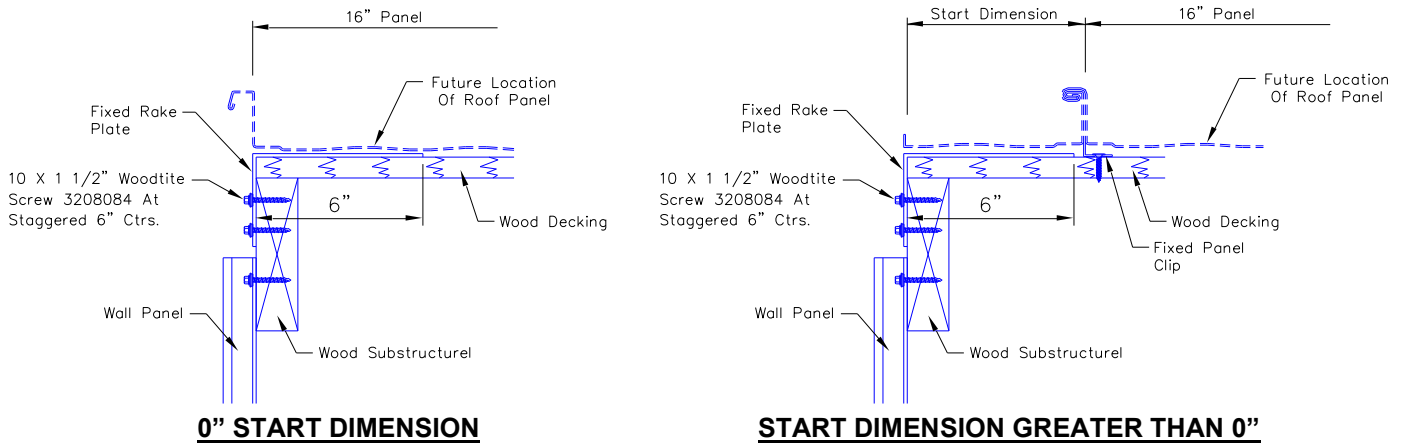

The position of the fixed rake plate will be located the same for roofs with or without start dimensions. The fixed rake plate is installed with 10x1 1/2" woodtite screws at a "staggered" 6" centers.

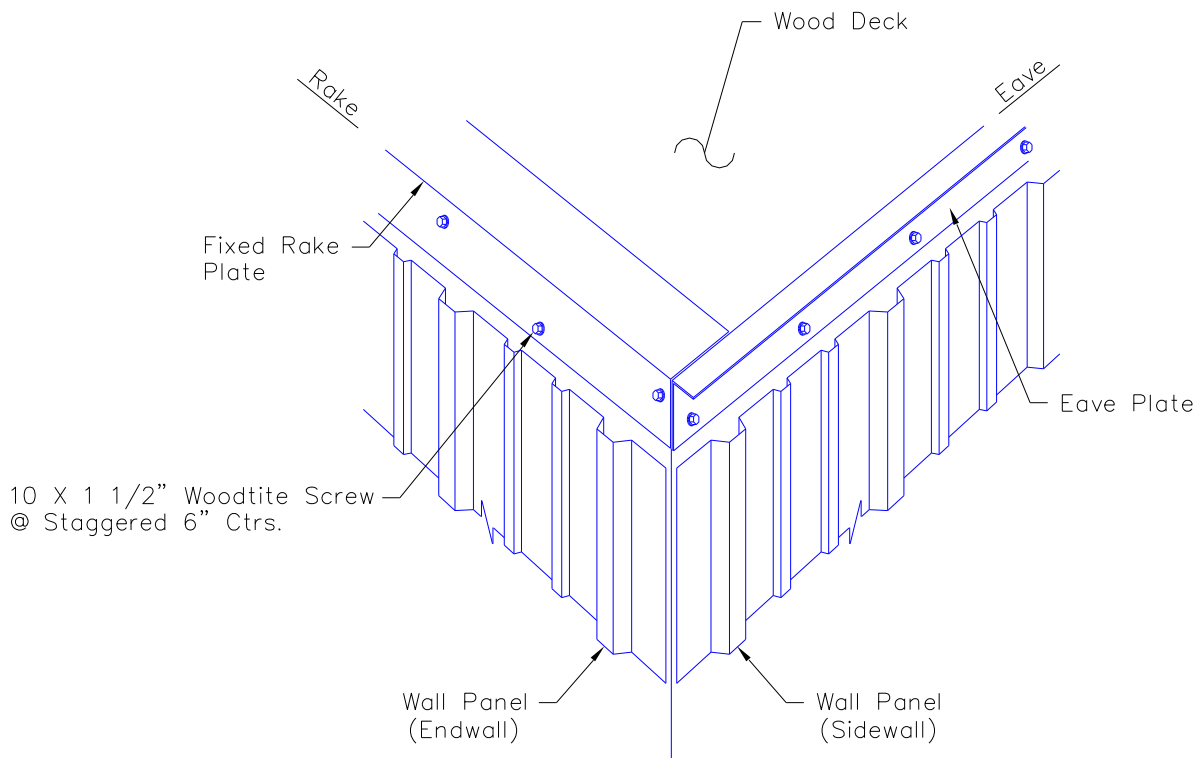

It is important that the fixed rake plate is installed in a straight line and parallel to the rake line. Start the fixed rake plate at the sidewall eave plate, butt join the ends of the rake plates.

ZL-16® Roof System Installation Guide

9.2.4 INSTALL EAVE TRIM

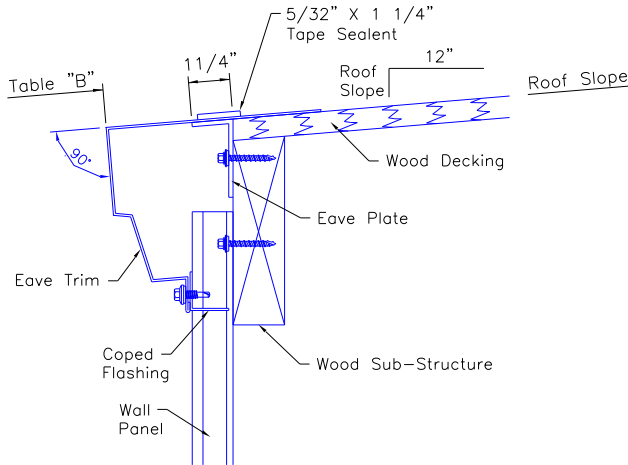
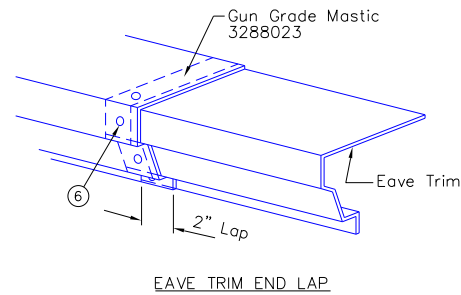
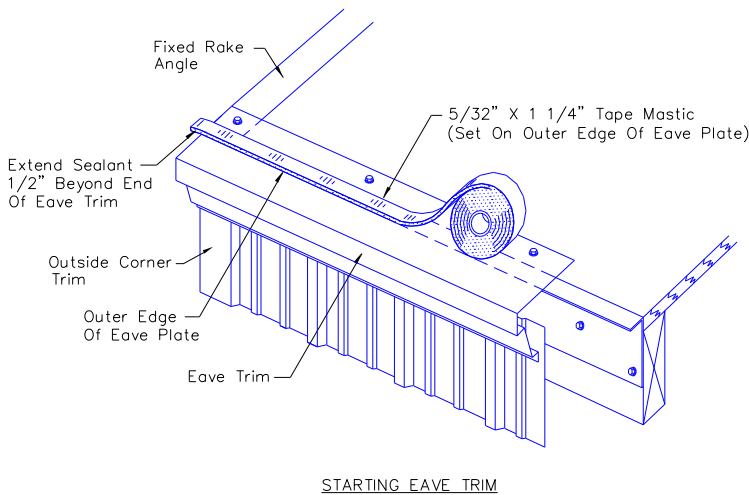

TABLE B	
ROOF SLOPE	DIMENSION
1/4" to 12"	2 3/8"
1/2" to 12"	2 7/16"
3/4" to 12"	2 9/16"
1" to 12"	2 11/16"
2" to 12"	3 1/8"
3" to 12"	3 9/16"
4" to 12"	4"
OTHERS	SEE PLANS



For clarity of details, insulation is not shown

Place the upper leg of the eave trim over the eave plate as shown and position, using dimensions in Table B. See erection plans for positioning eave trim on roof slopes greater than 4" to 12". Using these dimensions will keep the front face of the eave trim 90 degrees to the roof surface, assuring that the outside corner boxes will fit properly at the corners. Align the end of the eave trim with the face of the outside corner trim. The eave trim provides a water seal between the roof panel and the wall panel. Temporarily hold the eave trim in place with several (3) self-drilling screws. These screws should be removed prior to the placement of the roof panel.

Position the bottom edge of the eave trim along a caulk line. Insert coped flashing between eave trim and wall panel, then secure the trim to the wall panel, see Wall Erection Guide for spacing.

Install and align all other eave trim sections in the same manner allowing a minimum 2" lap. Each lap will contain (4) ⑥ trim screws and gun grade mastic. Apply a continuous strip of 5/32 x 1 1/4" tape sealant along the top of the eave trim. Align the outer edge of the sealant flush with the outer edge of the eave plate.

Do not remove the paper backing from the sealant at this time.

Until the roof panels are installed, the tape sealant is vulnerable to damage from foot traffic or dragging material over the eave. Do not step on or otherwise damage the sealant.

ZL-16® Roof System Installation Guide

9.2.5 INSTALL EAVE FLASHING

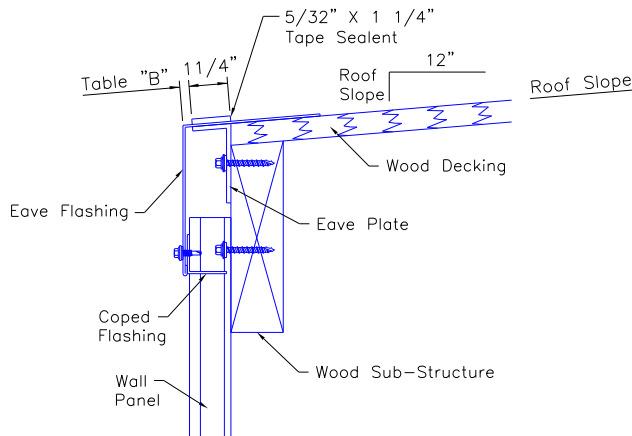

ROOF SLOPE	DIMENSION
1/4" to 12"	1/4"
1/2" to 12"	1/4"
3/4" to 12"	1/4"
1" to 12"	1/4"
2" to 12"	1/4"
3" to 12"	5/16"
4" to 12"	5/16"
OTHERS	SEE PLANS

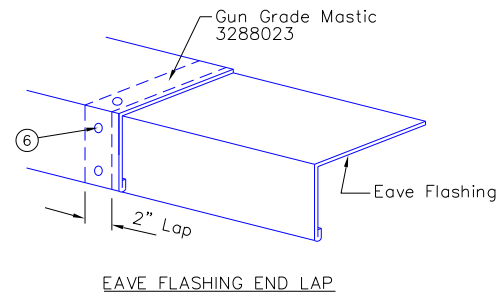
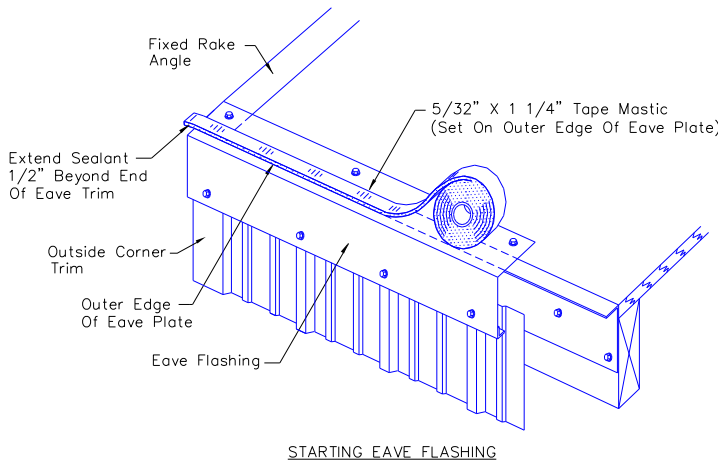

For clarity of details, insulation is not shown.

Place the upper leg of the eave flashing over the eave plate as shown and position, using dimensions in Table B. See Erection plans for positioning eave flashing on roof slopes greater than 4" to 12. Align the end of the eave flashing with the face of the outside corner trim. The eave flashing provides a water seal between the roof panel and the wall panels. Temporarily hold the eave flashing in place with several ③ self-drilling screws. These screws should be removed prior to the placement of the roof panel.

Position the bottom edge of the eave flashing along a caulk line. Insert coped flashing between eave flashing and wall panel, then secure the trim to the wall panel, see Wall Erection Guide for spacing.

Install and align all other eave flashing sections in the same manner allowing a minimum 2" lap. Each lap will contain (2)

⑥ trim screws and gun grade mastic.

Apply a continuous strip of 5/32" x 1 1/4" tape sealant along the top of the eave flashing. Align the outer edge of the sealant flush with the outer edge of the eave plate. Do not remove the paper backing from the sealant at this time. Until the roof panels are installed, the tape sealant is vulnerable to damage from foot traffic or dragging material over the eave. Do not step on or otherwise damage the sealant.

ZL-16® Roof System Installation Guide

9.2.6 FIRST ROOF PANEL PLACEMENT AND PANEL OVERHANG VERIFICATION

The position of the first panel in relationship to the endwall rake angle is critical. Check the erection set of plans for possible "START DIMENSION" and if field cutting of the first panel is required. If the panel is to be field cut, allow for a minimum 1" bent-up leg along the cut edge.

The starting panel edge should match the outer edge of the rake.

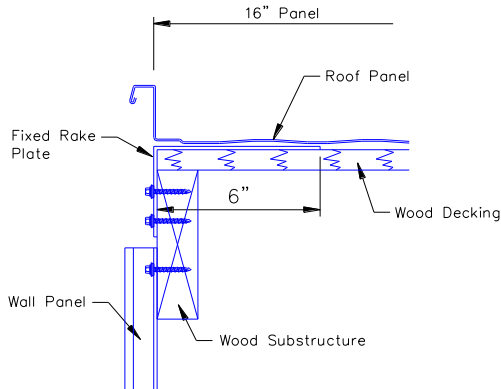

0" START DIMENSION

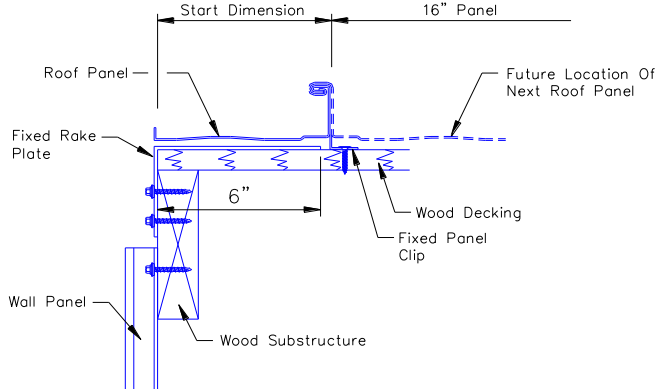

START DIMENSION GREATER THAN 0"

Position the roof panel along the rakeline and the end of the panel 4" beyond the eave line unless another dimension is specified on the erection drawings.

Rotate the panel down to rest on the wood deck.

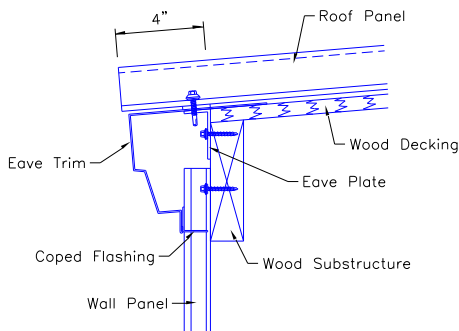

PANEL OVERHANG WITH EAVE TRIM

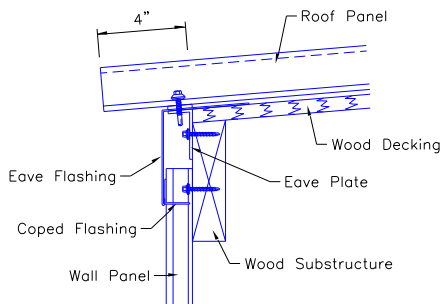

PANEL OVERHANG WITH EAVE FLASHING

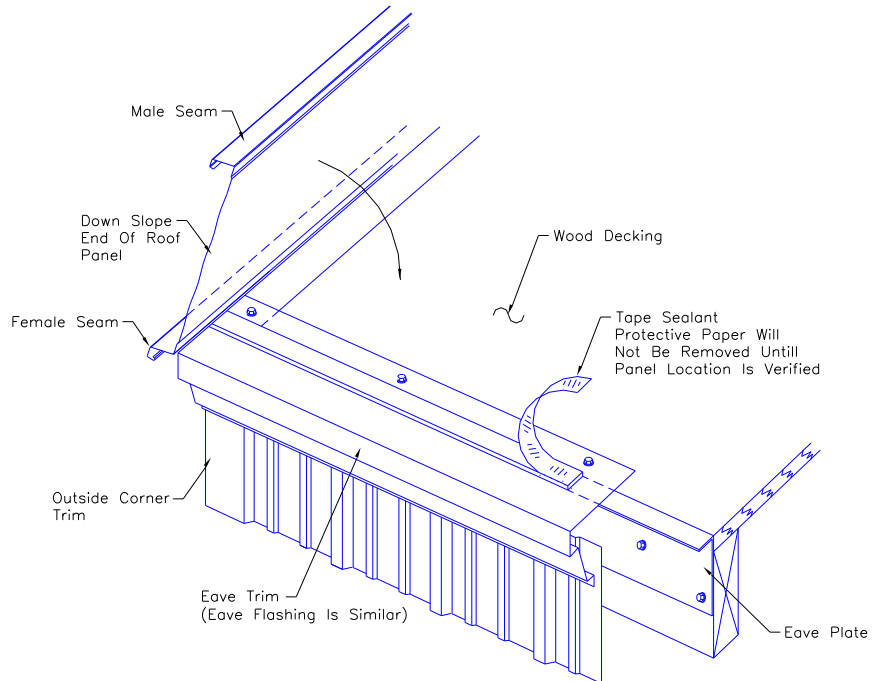

ROTATING PANEL DOWNWARDS

Before attaching the roof panel to the eave plate, measure the panel overhang at the upslope end and verify that it is in the correct position.

3/2/09

ZL-16® Roof System Installation Guide

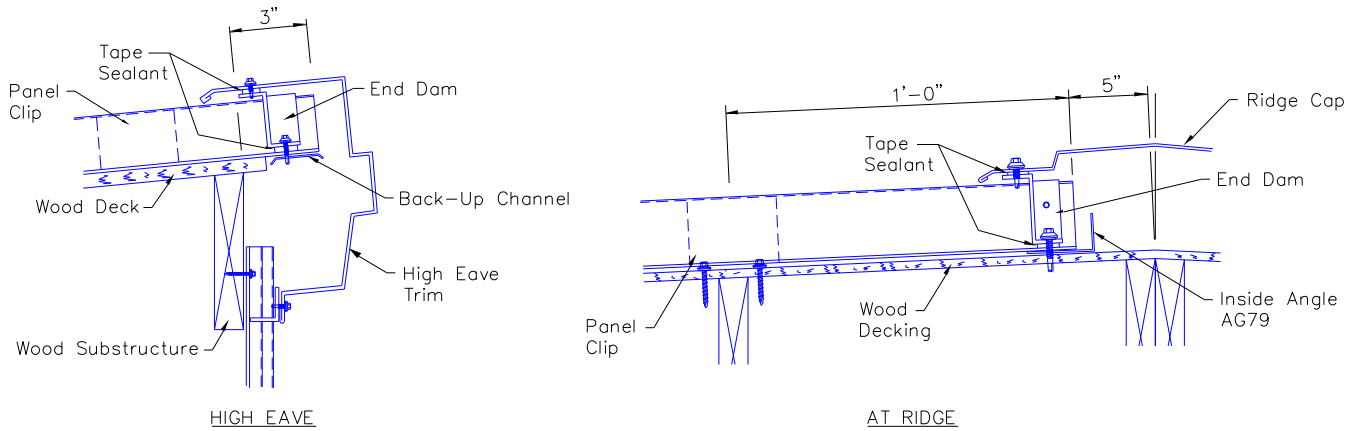

The roof panel's eave overhang dimension is critical as it establishes the location of high eave and ridge cover attachment points.

Verify that the roof panel's overhang dimension is correct and verify that the roof panel is aligned parallel to the rake line.

Raise the leading corner of the panel and remove the protective paper from the tape sealant.

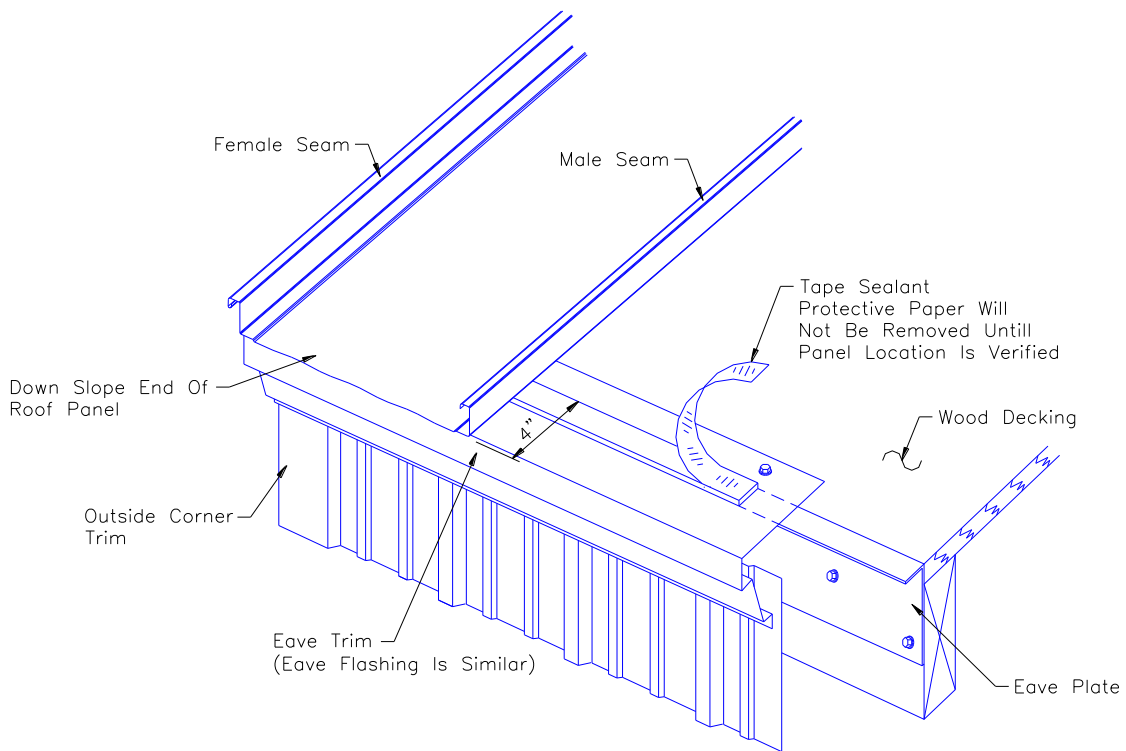

Before fastening the roof panel to the eave plate and fastening the leading edge of the panel with the panel clips, check that the panel coverage is correct and the leading edge of the panel is straight and parallel to the rake line.

ZL-16® Roof System Installation Guide

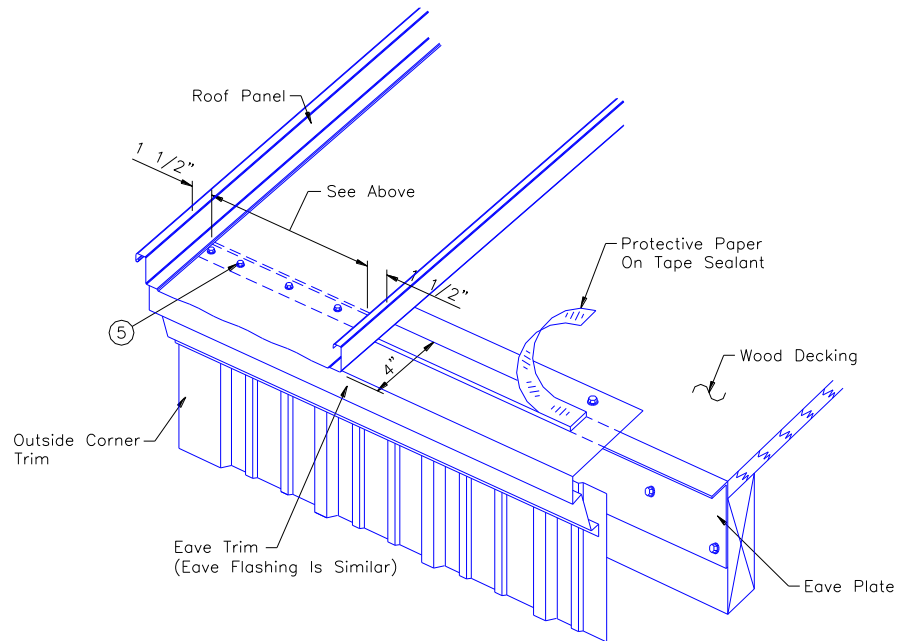
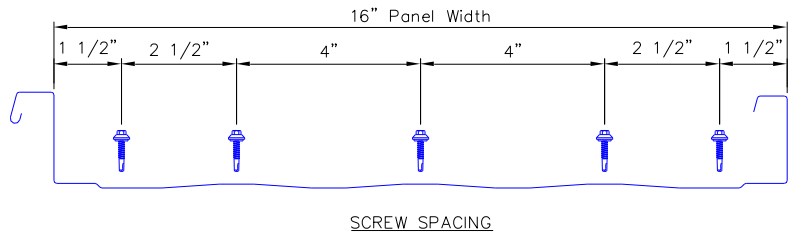

Fasten the eave end of the panel with (5) ⑤ self-drilling screws as shown above unless the (optional) cinch strap is used, then see below.

Position the fasteners to penetrate through the center of the sealant, through the eave flashing or eave trim and into the eave plate.

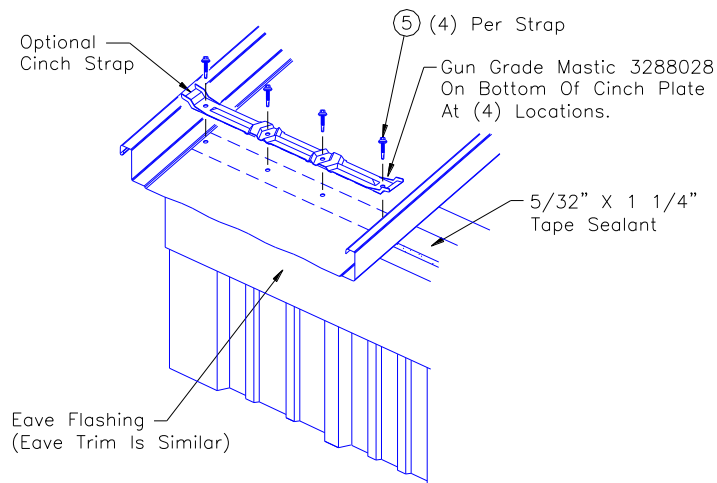

If the (optional) cinch strap is used apply gun grade mastic to the bottom of the cinch strap at the hole locations, then position the strap so that the fasteners will penetrate through the center of the sealant, eave trim and into the eave plate.

ZL-16® Roof System Installation Guide

9.2.7 ATTACHING PANEL CLIPS

Install roof panel clips to the leading edge of the roof panel at the locations noted in the Erection Drawings. Panel clips are not required at the low eave line, but will be used at the high eave line on single slope buildings.

To install the clips, tilt the clip so that its tab can be hooked over the edge of the roof panel's male seam. Position the clip's base so that the clip fasteners can be installed through the holes in the base and into the wood deck, then rotate the clip down into the vertical position.

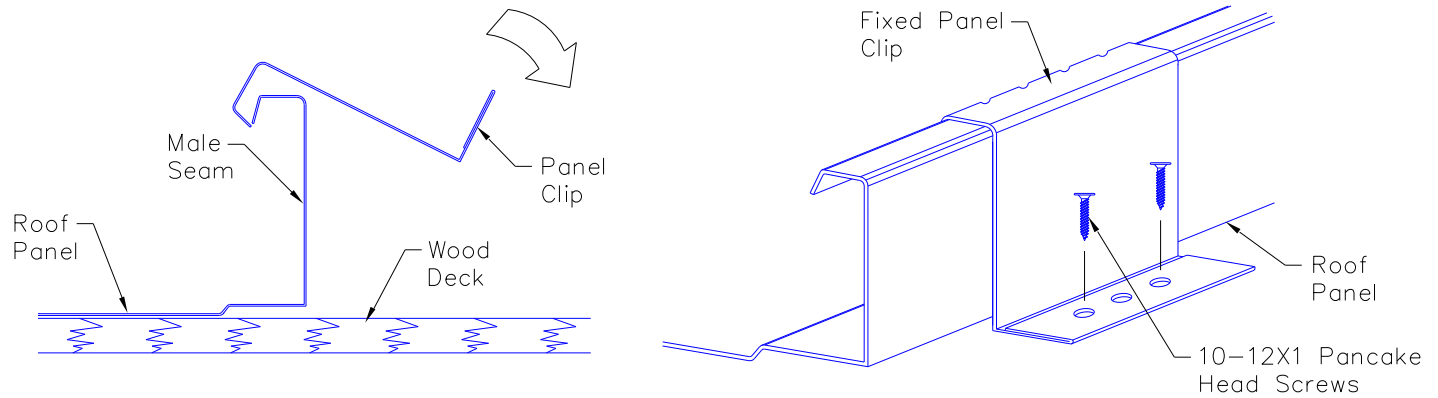

CLIP AND PANEL ASSEMBLY

CAUTION: Failure to enclose the male lip in the clip hook and failure to nest the clip flush against the vertical leg on the panel can cause faulty seaming and objectionable seam appearance.

Panel clips are available as “fixed” clips only and are available in a 0” stand-off height. Refer to the erection drawings to determine the spacing used.

Check that the panel clip's tab is seated tightly around the roof panel's seam and that the panel clip hook, has captured the panel's lip.

Check that the clip's base is vertical and that the base is set square and firmly over the wood deck.

The “fixed” panel clip will be secured to the (minimum 5/8” thick) wood deck with two #10-12x1” wafer head screws (part no. 3228139) unless specified otherwise in the erection drawings.

ZL-16® Roof System Installation Guide

9.2.8 ATTACHMENTS AT RIDGE

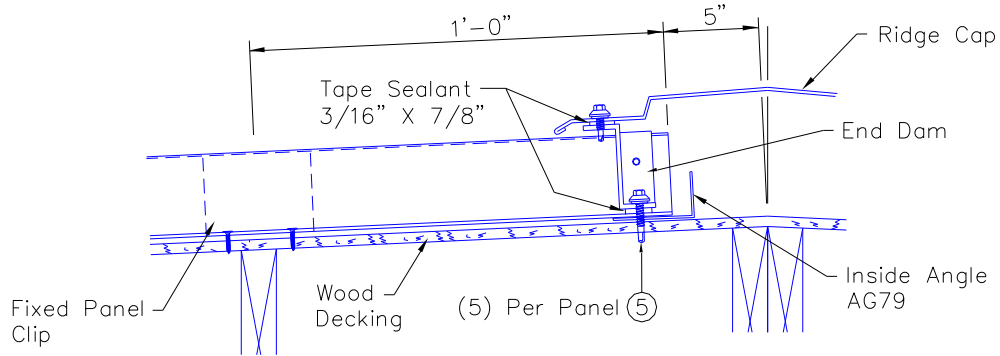

A line of inside angles, which are 15'-0 long, will be used along the ridge line to back-up the end dam to roof panel connection. The ⑤ self-drilling screws should pass-through the inside angles.

For additional information on installing ridge components see sections 9.8, 9.11, 9.12 and 9.13.

9.2.9 ATTACHMENTS AT HIGH EAVE

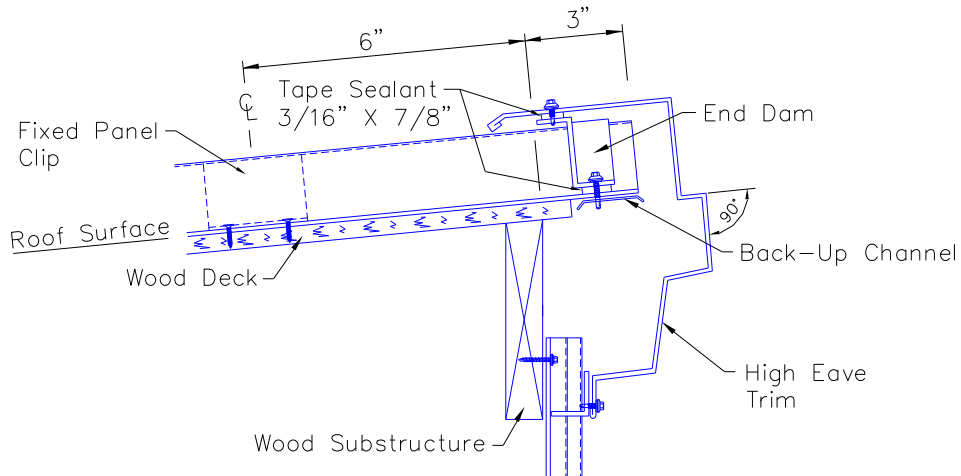

A line of panel clips will be used along the high eave line. For additional information on other high eave components, see sections 9.11 and 9.14.

ZL-16® Roof System Installation Guide

9.2.10 ATTACHMENTS AT RAKE

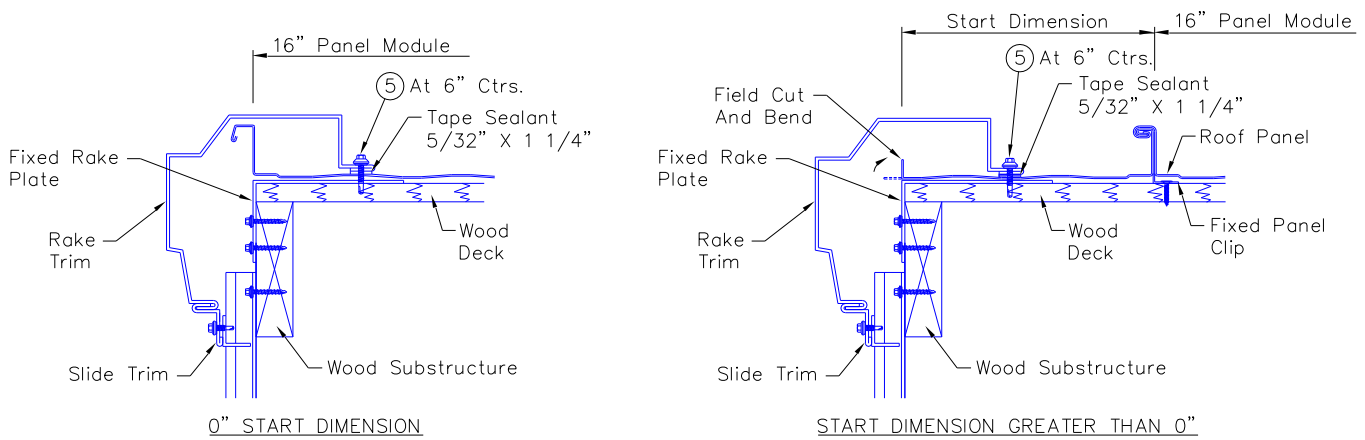

When installing rake trims along the endwall rake the ⑤ self-drilling screws should pass-through the tape sealant, panel and the fixed rake plate.

For additional information on other rake trim components, see sections 9.11, 9.12, 9.13, 9.14 and 9.15.

For information on seaming the roof, see sections 12 through 21.

ZL-16® Roof System Installation Guide

9.3 PREPARATION FOR ROOF PANEL INSTALLATION OVER SECONDARY FRAMING (PURLINS)

9.3.1 ORIENTATION VIEW

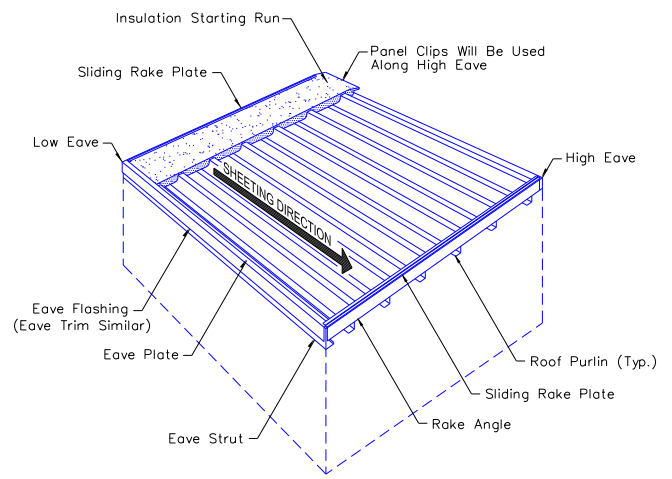
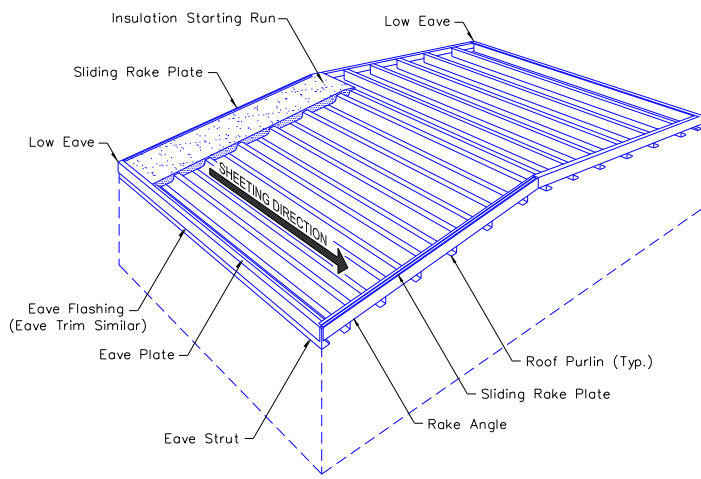

The details in this section will show the installation of the sliding rake plate along the endwall rake, and along the low eave the eave plate, eave flashing, eave trim and the first run of insulation. These are parts that must be installed before the roof panel installation can begin.

This view shows the roof system oriented for a left-to-right sheeting direction.

Sliding rake plates are required at both ends of building. Refer to the erection drawings for the required rake conditions.

ZL-16® Roof System Installation Guide

9.3.2 INSTALL EAVE PLATE

ROOF SLOPE	DIMENSION		OFFSET
	3/8" STAND-OFF	1 3/8" STAND-OFF	
1/4:12	1 1/4"	1 1/4"	0
1/2:12	1 1/4"	1 5/16"	0
3/4:12	1 1/4"	1 5/16"	0
1:12	1 5/16"	1 3/8"	0
2:12	1 5/16"	1 1/2"	1/16"
3:12	1 3/8"	1 5/8"	1/8"
4:12	1 3/8"	1 11/16"	3/16"
OTHERS	SEE PLANS		

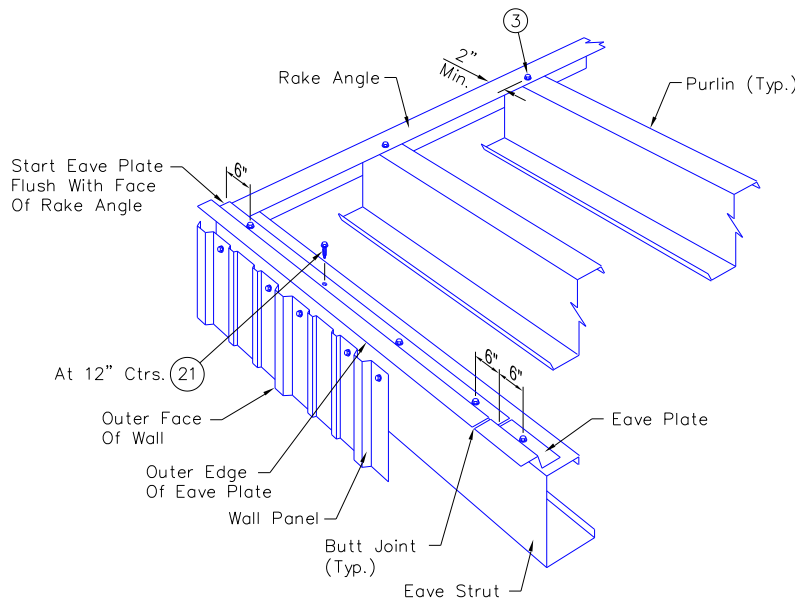
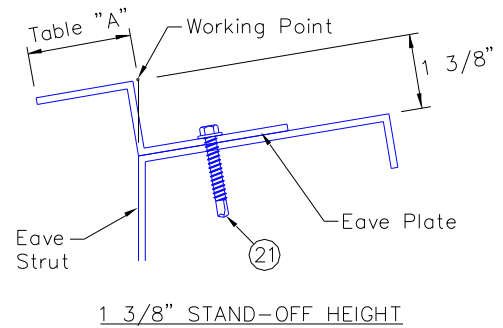
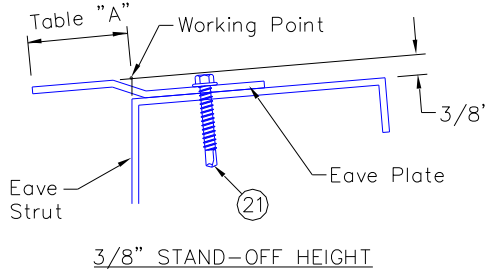
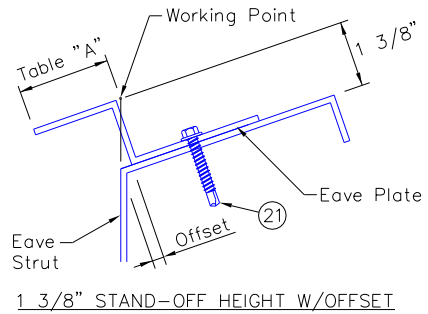

The eave plate provides a solid attachment surface for the low eave end of the roof panel. Eave plates should never be placed at the high eave on single slope buildings. Use applicable dimension from TABLE A to locate the eave plate in relationship to the eave strut.

The eave plate must be installed before the roof insulation is placed over the structurals. Use (21) Self drilling Screws at 12" centers to attach eave plate to eave strut. Before installing the eave plate, check that the eave strut members are in straight alignment from rake to rake. Shim the eave plate as necessary to provide a level of roof line. Install the starting and finish ends of the eave plates flush with outer face of rake angle.

8/29/08

ZL-16® Roof System Installation Guide

9.3.3 INSTALL FIRST RUN OF INSULATION

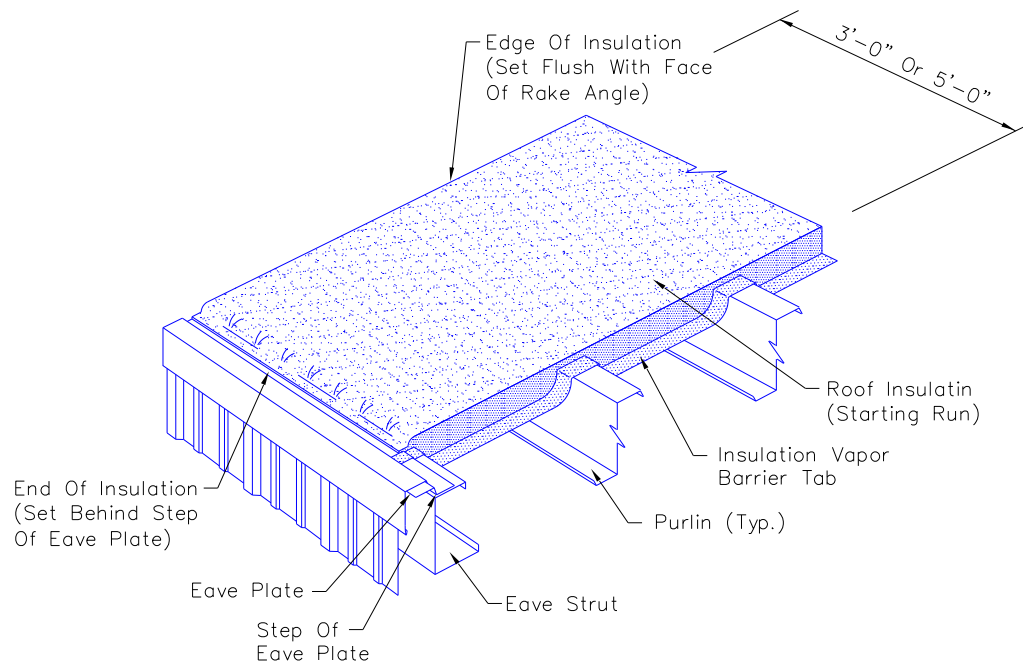

Refer to the erection drawings to determine the specific insulation required for the project. In all cases refer to the insulation manufacturer's instructions for proper insulation installation and vapor seal assembly. This detail shows fiberglass blanket insulation, which is the most commonly used insulation for metal standing seam roofs.

The leading edge of each insulation run should extend approx. 12" beyond the leading edge of the roof panel. This will allow for easy assembly of the vapor barrier seal between insulation runs.

With four foot or six foot wide insulation, the first run should be installed to only cover three feet or five feet respectively. The extra foot of width can butt or lap over the rake.

It is important to cut back insulation to 1" thick at the rake prior to installing the sliding rake plate on top. This will give the roof a chance to move, and also will hold down the insulation during installation.

Use two rows of double-faced tape along the top of the eave strut and eave plate to hold the insulation in place until the roof panel is installed.

In all cases do not extend the end of the insulation onto the high flange of the eave plate.

ZL-16® Roof System Installation Guide

9.3.4 SLIDING RAKE PLATE POSITIONED FOR RAKE TRIM

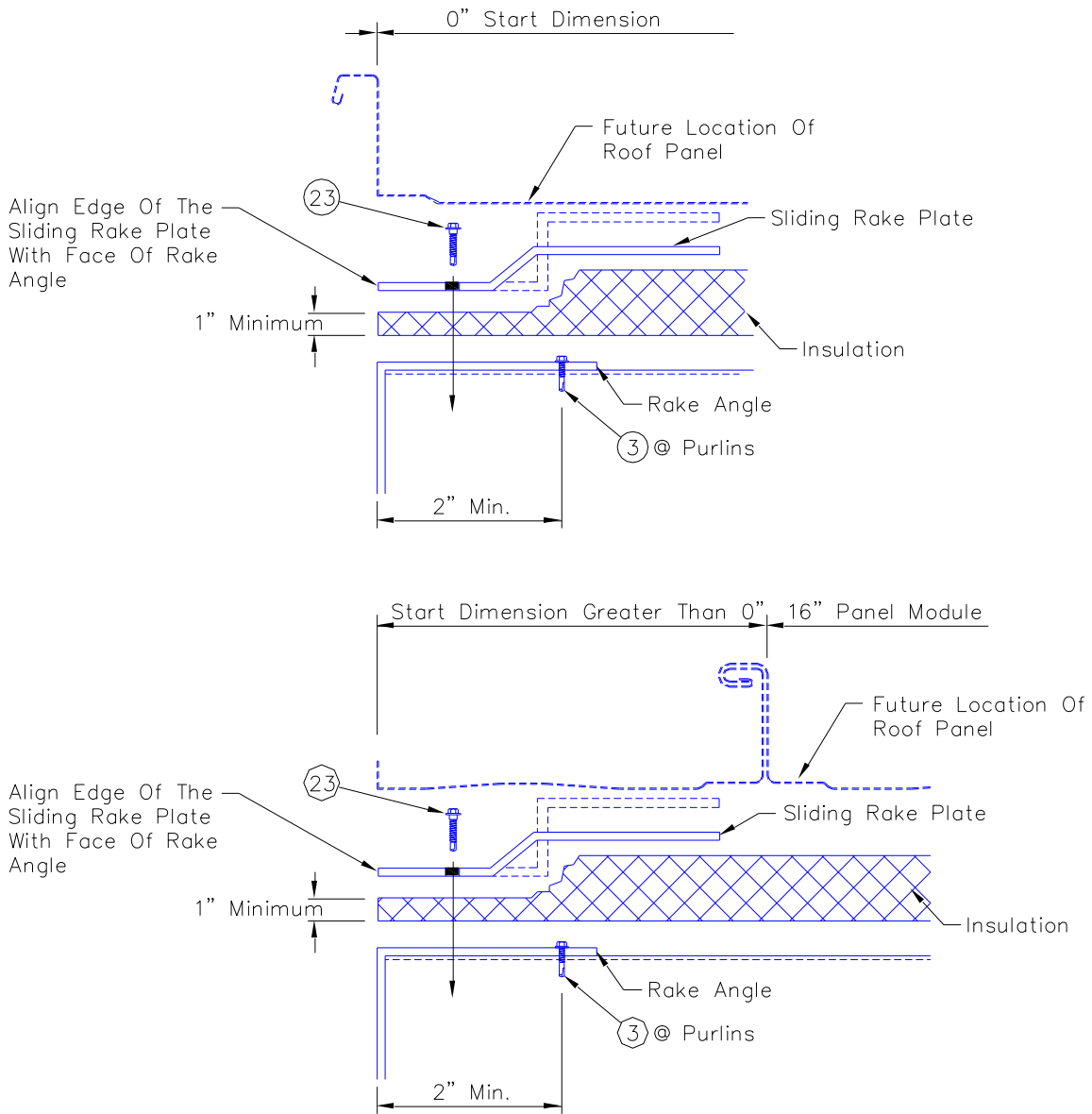

The position of the sliding rake plate will be located the same for roofs with or without a roof panel start dimension.

The rake angle is installed with ③ self-drilling screws at each purlin and eave strut prior to installing sliding rake plate.

The sliding rake plate is attached to the rake angle with a ②③ self-drilling "shoulder" screw in the center of the slot at 24" centers.

3/2/09

ZL-16® Roof System Installation Guide

9.3.5 START SLIDING RAKE PLATE INSTALLATION

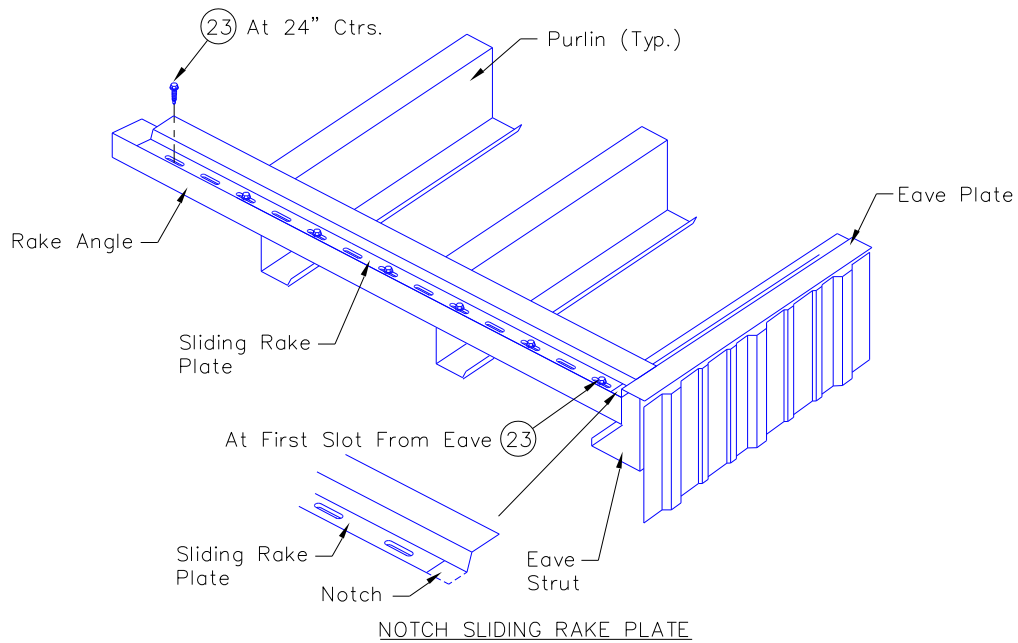
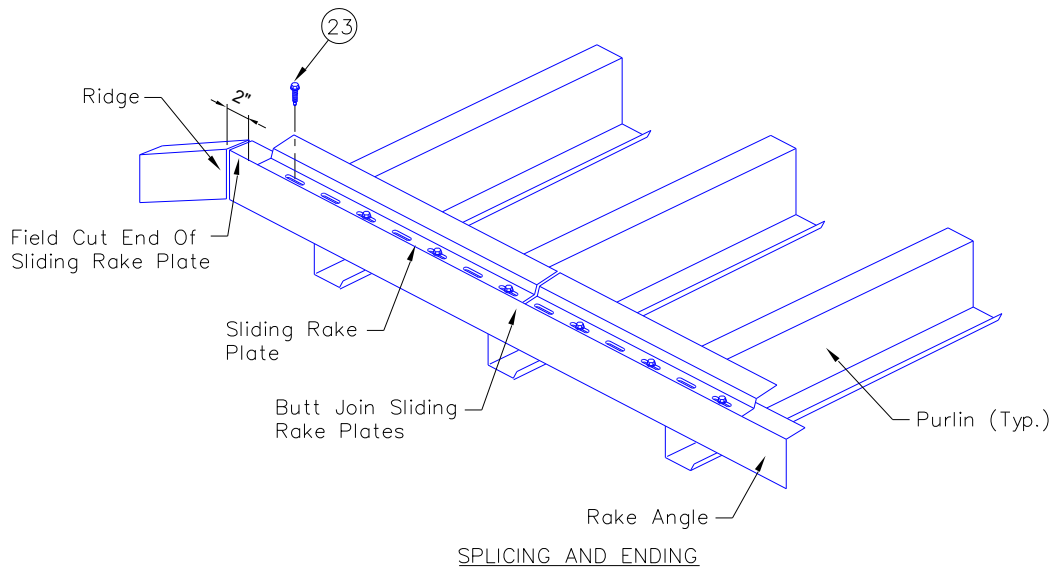

START AT EAVE

For clarity of detail, insulation is not shown

It is important that the sliding rake plate is installed in a straight line and parallel to the rake line. If the rake angles have been installed straight and true, the edge of the rake angle can be used to align the sliding rake plate. If the rake angle is not true and square, a chalkline should be used to guide the installation of the sliding rake plate.

8/29/08

ZL-16® Roof System Installation Guide

Start the end of the sliding rake plate flush with the inside edge of the eave plate.

Secure the starting end of the sliding rake plate with a ② self-drilling shoulder screw in the sliding rake plate's first slot. To allow for expansion/contraction movement, secure the rest of the sliding rake plate run to the rake angle with screws spaced as shown. Install the shoulder fasteners in the center of the slots.

Butt join the ends of the sliding rake plates. Install the shoulder fasteners in the slots on either side of the butt joints. Field cut the last sliding rake plate two inches (2") from the ridge line or high eave line.

9.3.6 INSTALLING EAVE TRIM

TABLE B		
ROOF SLOPE	DIMENSION	
	3/8" STAND-OFF	1 3/8" STAND-OFF
1/4 : 12	2 3/8"	2 5/16"
1/2 : 12	2 7/16"	2 3/8"
3/4 : 12	2 9/16"	2 1/2"
1 : 12	2 5/8"	2 9/16"
2 : 12	3 1/16"	2 7/8"
3 : 12	3 7/16"	3 3/16"
4 : 12	3 7/8"	3 9/16"
OTHERS	SEE PLANS	

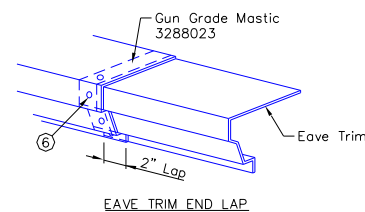
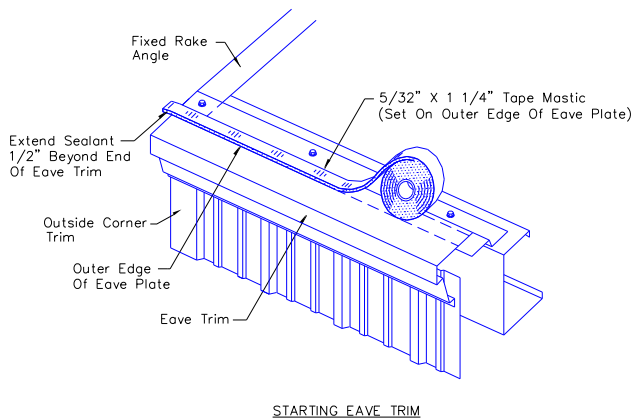
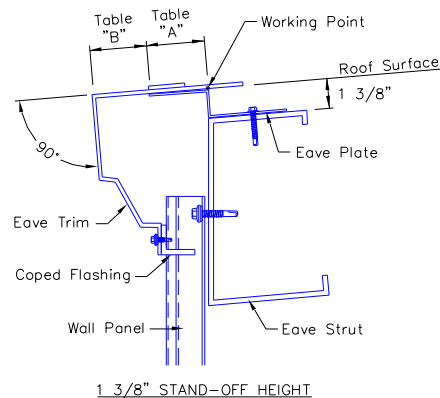
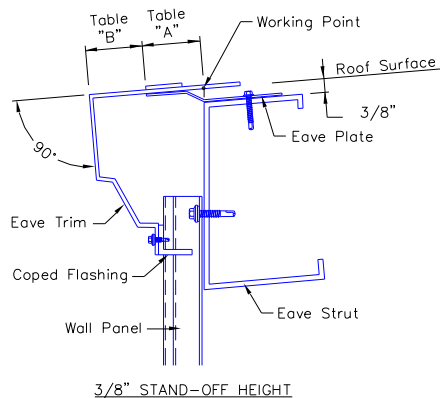

For clarity of details, insulation is not shown.

Place the upper leg of the eave trim over the eave plate as shown and position, using dimensions in Table B. See erection plans for positioning eave trim on roof slopes greater than 4" to 12". Using these dimensions will keep the front face of the eave trim 90 degrees to the roof surface, assuring that the outside corner boxes will fit properly at the corners. Align the end of the eave trim with the face of the outside corner trim. The eave trim provides a waterseal between the roof panel and the wall panel. Temporarily hold the eave trim in place with several ③ self-drilling screws. These screws should be removed prior to the placement of the roof panel.

ZL-16® Roof System Installation Guide

Position the bottom edge of the eave trim along a caulk line. Insert coped flashing between eave trim and wall panel, then secure the trim to the wall panel, see wall Erection Guide for spacing.

Install and align all other eave trim sections in the same manner allowing a minimum 2" lap. Each lap will contain (4) ⑥ trim screws and gun grade mastic.

Apply a continuous strip of tape sealant along the top edge of the eave flashing. Align the outer edge of the sealant flush with the outer edge of the eave plate.

Do not remove the paper backing from the sealant at this time.

Until the roof panels are installed, the tape sealant is vulnerable to damage from foot traffic or dragging material over the eave. Do not step on or otherwise damage the sealant.

9.3.7 INSTALLING EAVE FLASHING

TABLE B		
ROOF SLOPE	DIMENSION	
	3/8" STAND-OFF	1 3/8" STAND-OFF
1/4:12	1/4	1/4
1/2:12	1/4	3/16
3/4:12	1/4	3/16
1:12	1/4	1/8
2:12	3/16	1/16
3:12	3/16	1/16
4:12	3/16	1/16
OTHERS	SEE PLANS	

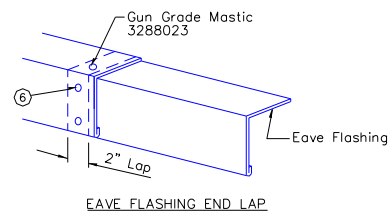
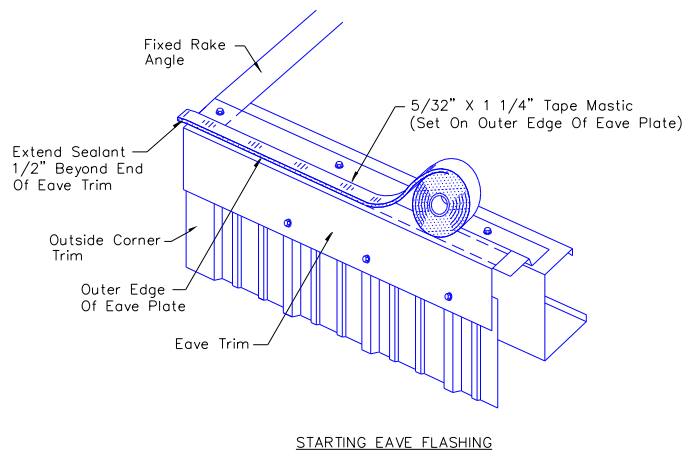
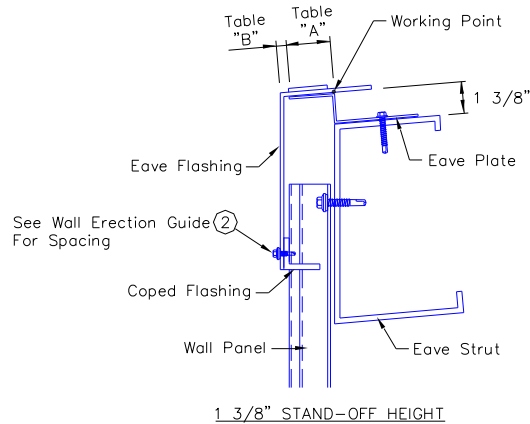
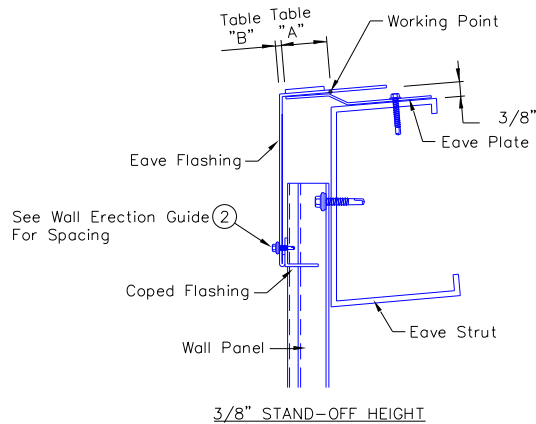

ZL-16® Roof System Installation Guide

Place the upper leg of the eave flashing over the eave plate as shown and position, using dimensions in Table B. See erection plans for positioning eave flashing on roof slopes greater than 4" to 12. Align the end of the eave flashing with the face of the outside corner trim. The eave flashing provides a water seal between the roof panel and the wall panels. Temporarily hold the eave flashing in place with several (3) self-drilling screws. These screws should be removed prior to the placement of the roof panel.

Position the bottom edge of the eave flashing along a caulk line. Insert coped flashing between eave flashing and wall panel, then secure the trim to the wall panel, see Wall Erection Guide for spacing.

Install and align all other eave flashing sections in the same manner allowing a minimum 2" lap. Each lap will contain (2) (6) trim screws and gun grade mastic.

Apply a continuous strip of tape sealant along the top edge of the eave flashing.

Align the outer edge of the sealant flush with the outer edge of the eave plate.

Do not remove the paper backing from the sealant at this time.

Until the roof panels are installed, the tape sealant is vulnerable to damage from foot traffic or dragging material over the eave. Do not step on or otherwise damage the sealant.

9.4 ROOF PANEL INSTALLATION

9.4.1 ORIENTATION VIEW

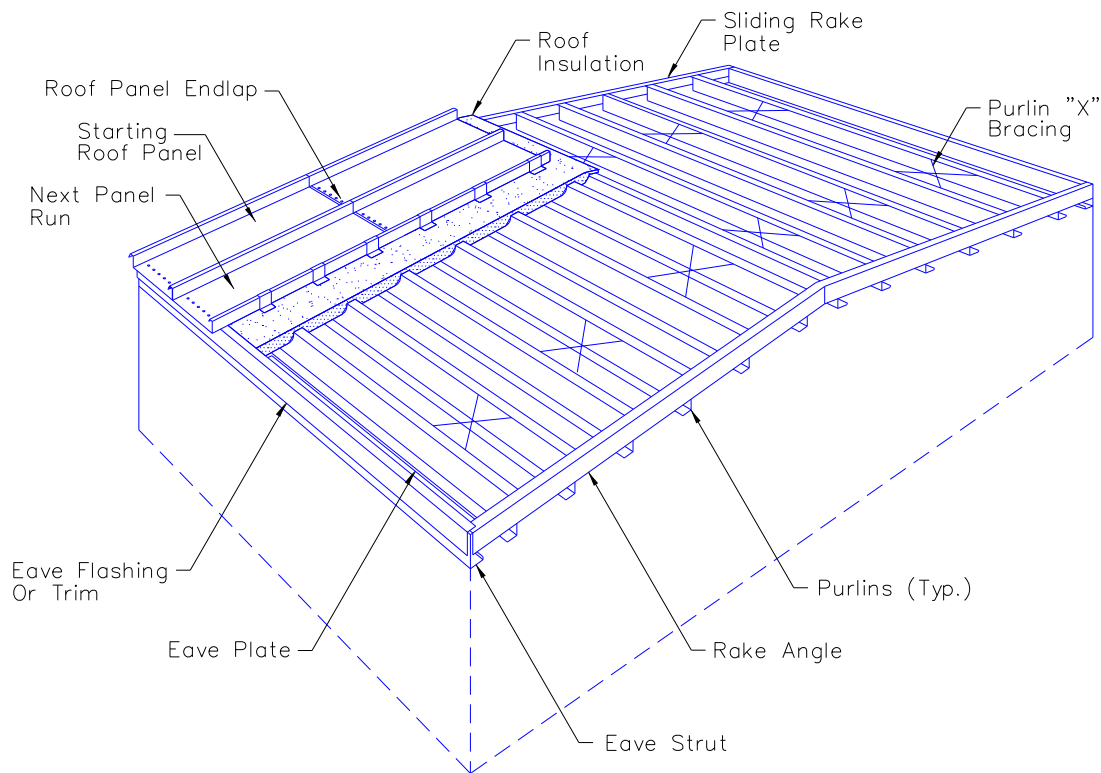

The details in this section show installation of the starting and subsequent roof panels.

The roof panel endlap details are shown as an integral part of the roof panel installation. If the project does not require roof panel endlaps, the endlap details are clearly identified and can be disregarded.

The (optional) cinch straps will be shown at the eaveline and at the panel endlaps. If the project does not require cinch straps that information can be disregarded.

Installation of the last panel run is shown in Section 9.10.1

ZL-16® Roof System Installation Guide

9.4.2 FIRST ROOF PANEL PLACEMENT

The position of the first panel in relationship to the endwall rake angle is critical. Check the erection set of plans for possible "START DIMENSION" and if field cutting of the first panel is required. If the panel is to be field cut, allow for a minimum 1" bent-up leg along the cut edge.

The starting panel edge should match the outer edge of the rake.

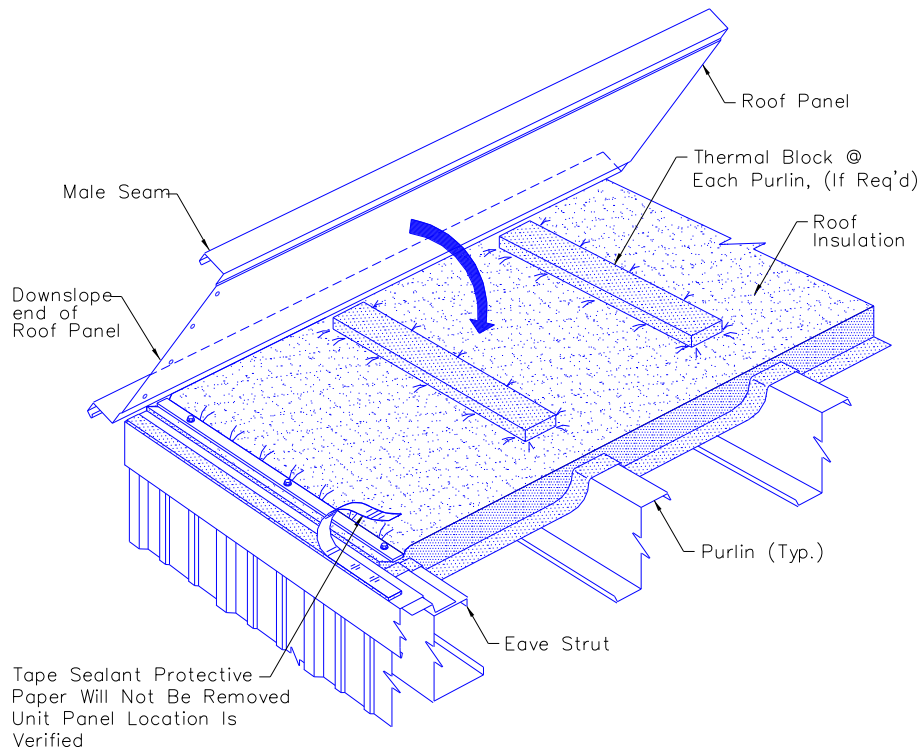
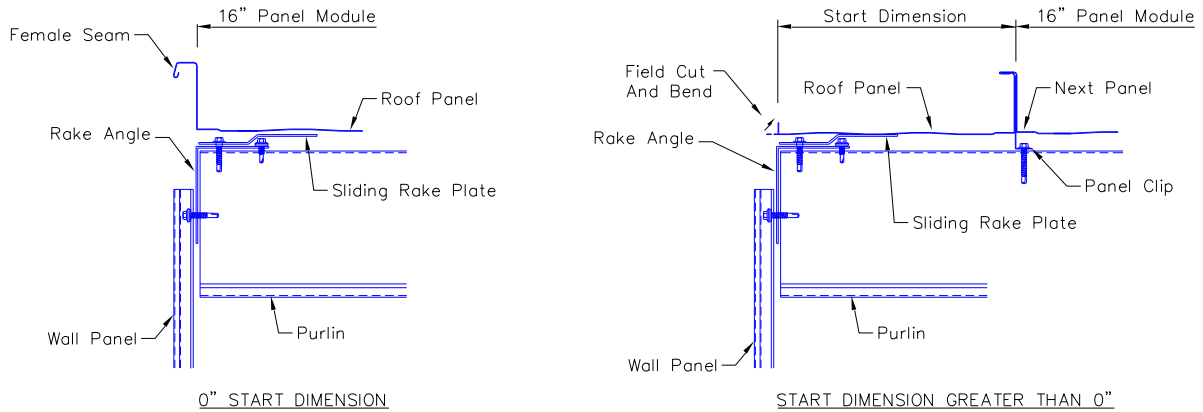

If thermal blocks are required, see insulation and thermal block combinations on page 23 to confirm thermal block thickness then place the blocks on top of the insulation directly over the roof structurals. On some roof slopes it may be advantageous to use a spray-on adhesive on the thermal block to keep it positioned over the roof structural's until the panel is installed. Thermal blocks are not required at the eave strut. Position the roof panel along the rake line and the end of the panel 4" beyond the eave strut unless another dimension is specified on the erection drawings.

Rotate the panel shown to rest on the thermal blocks or insulation.

8/29/08

ZL-16® Roof System Installation Guide

9.4.3 PANEL OVERHANG VERIFICATION

Before attaching the roof panel to the eave plate, measure the panel overhang at the purlin on the upslope end and verify that it is in the correct position.

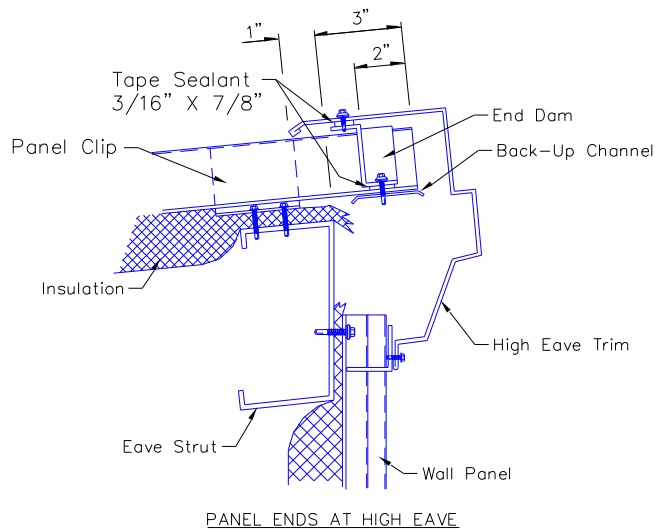
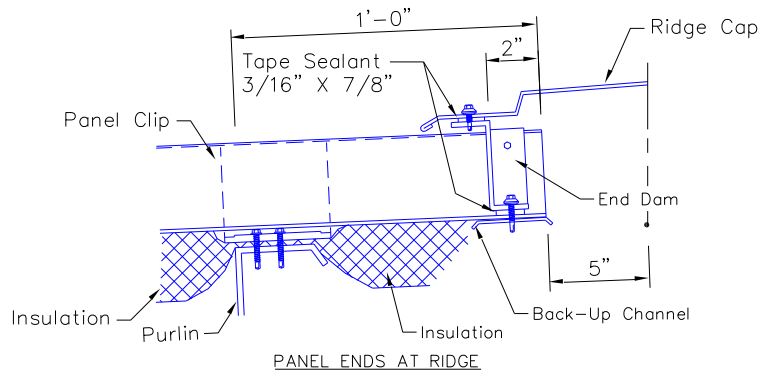
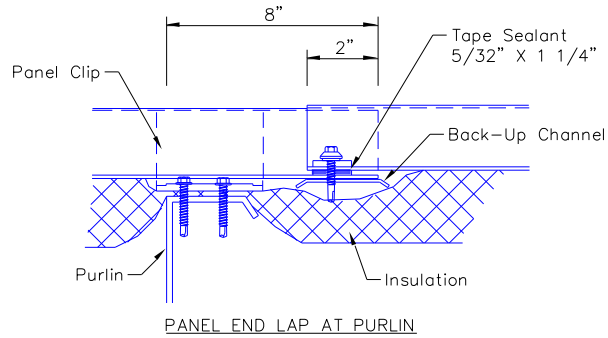

ZL-16® Roof System Installation Guide

9.4.4 ATTACHING ROOF PANEL AT EAVE

Before fastening the roof panel to the eave plate and fastening the leading edge of the panel with the panel clips, check that the panel coverage is correct and the leading edge of the panel is straight and parallel to the rake line.

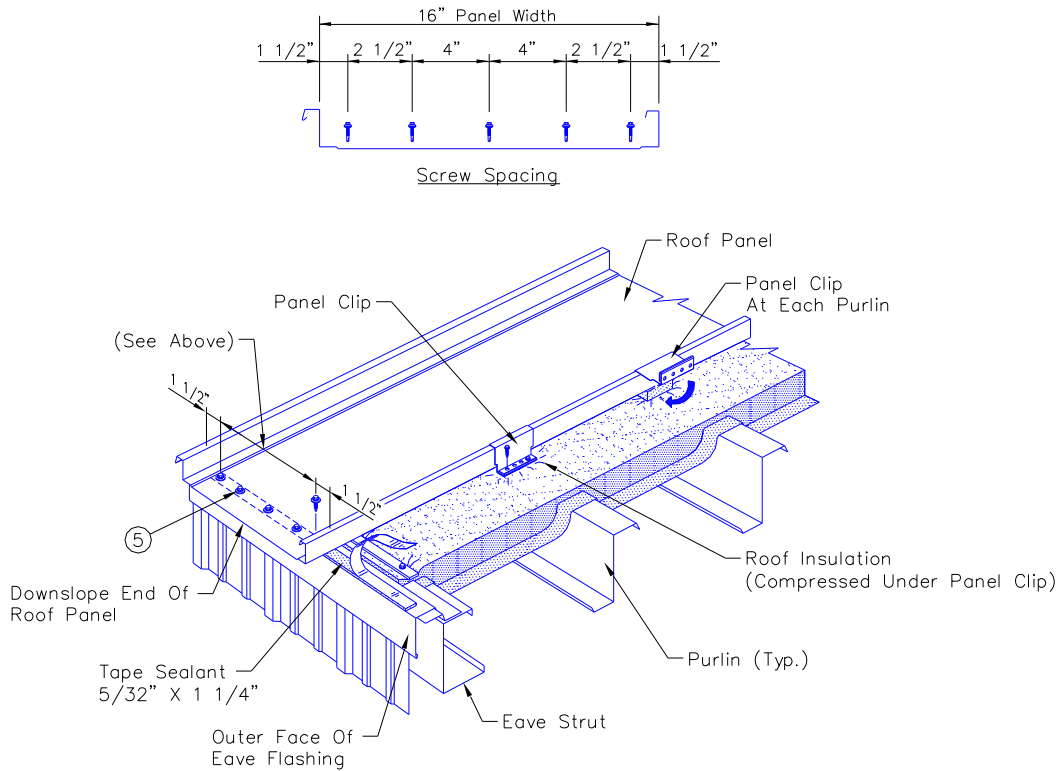

Fasten the eave end of the panel with (5) ⑤ self-drilling screws as shown above unless the (optional) cinch strap is used, then see below.

Position the fasteners to penetrate through the center of the sealant, through the eave flashing and into the eave plate.

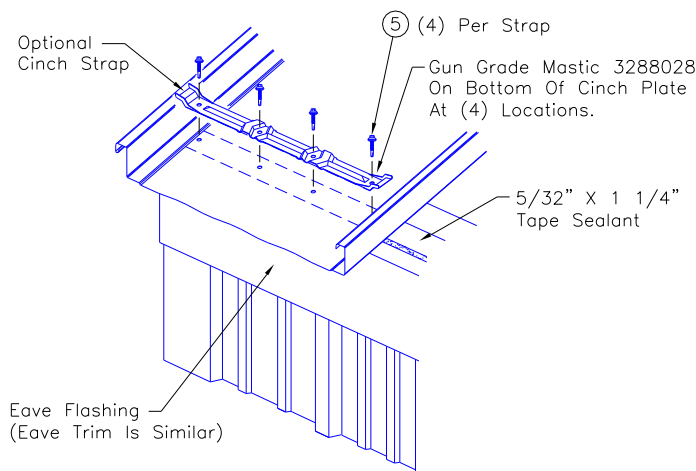

If the (optional) cinch strap is used, apply gun grade mastic to the bottom of the cinch strap at the hole locations, then position the strap so that the fasteners will penetrate through the center of the sealant, eave trim and into the eave plate.

ZL-16® Roof System Installation Guide

9.4.5 ATTACHING PANEL CLIP

Install roof panel clips to the leading edge of the roof panel at each roof purlin. Panel clips are not required at the low eave strut but will be used at the high eave strut on single slope building.

To install the clips, tilt the clip so that its tab can be hooked over the edge of the roof panel's male seam. Position the clip's base so that the clip fasteners can be installed through the holes in the base and into the roof purlin, and then rotate the clip down into the vertical position.

When fiberglass roof insulation is used, the panel clips normally set on top of the insulation and the insulation is compressed between the clip's base and the top of the roof purlin. In all cases, refer to the erection drawings to determine the required insulation assembly and the relationship of the panel clips to the insulation.

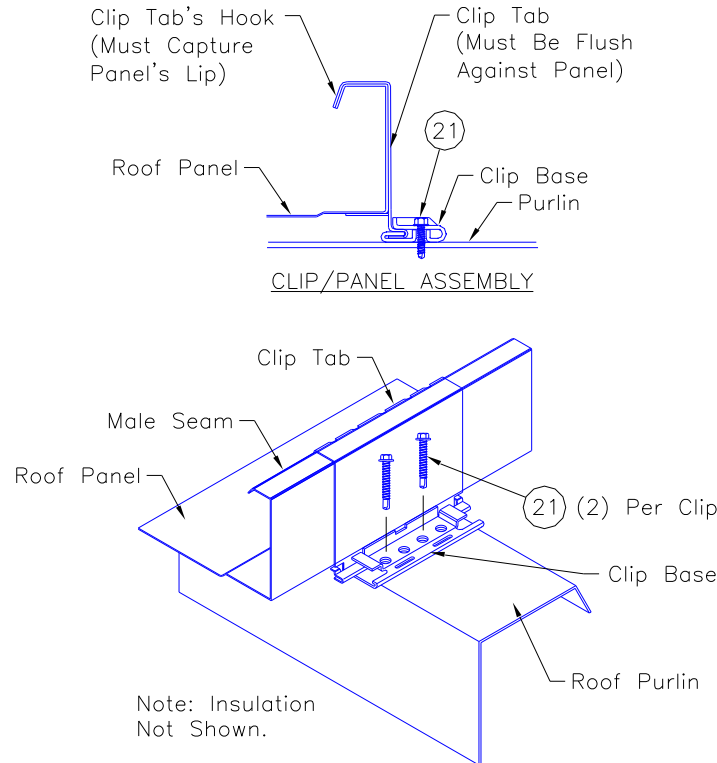

CAUTION: Failure to enclose the male lip in the clip hook and failure to nest the clip flush against the vertical leg on the panel can cause faulty seaming and objectionable seam appearance.

Panel clips are available as floating clips only and are available in different stand-off heights. Refer to the erection drawings to determine the type of clip required for each roof condition.

Check that the panel clip's tab is seated tightly around the roof panel's seam and that the panel clip's hook has captured the panel's lip.

Check that the clip's tab is seated tightly around the roof panel's seam and that the panel clip's hook has captured the panel's lip.

Check that the clip's base is vertical and that the base is set square and firmly over the roof purlins.

Panel clip fastener type and quantity vary according to the roof structural material and roof load requirements. Refer to the erection drawings for the required type and quantity of panel clip fasteners.

Check that the clip fasteners are equally spaced through the clip base holes and are securely engaged into roof purlin.

8/29/08

ZL-16® Roof System Installation Guide

9.4.6 TEMPORARY ROOF PANEL TIE-DOWN

If the rake trim is to be installed later, the edge of the first panel run should be temporarily clamped to the rake angle. Any attachment along the rake must be removed when the rake trim is installed.

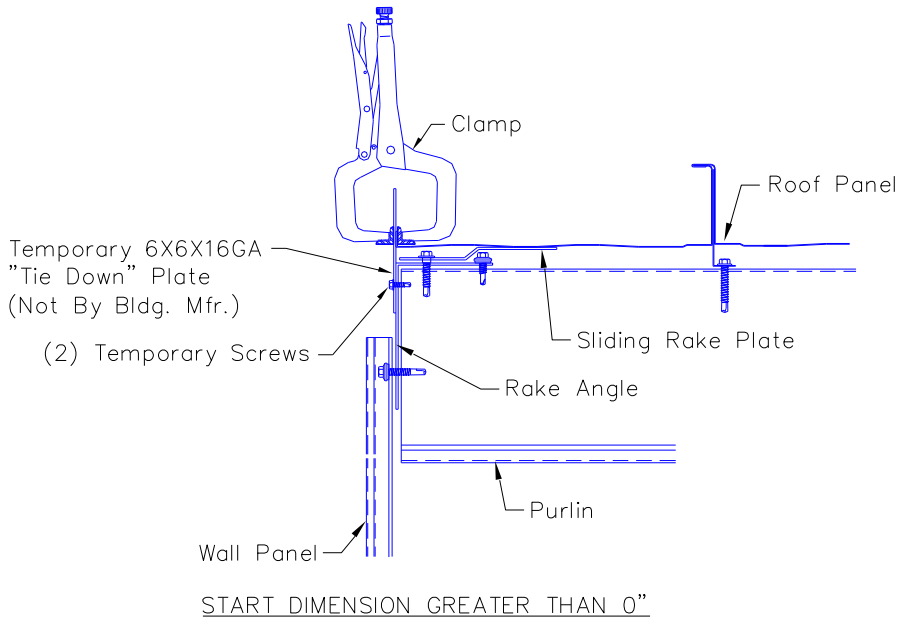
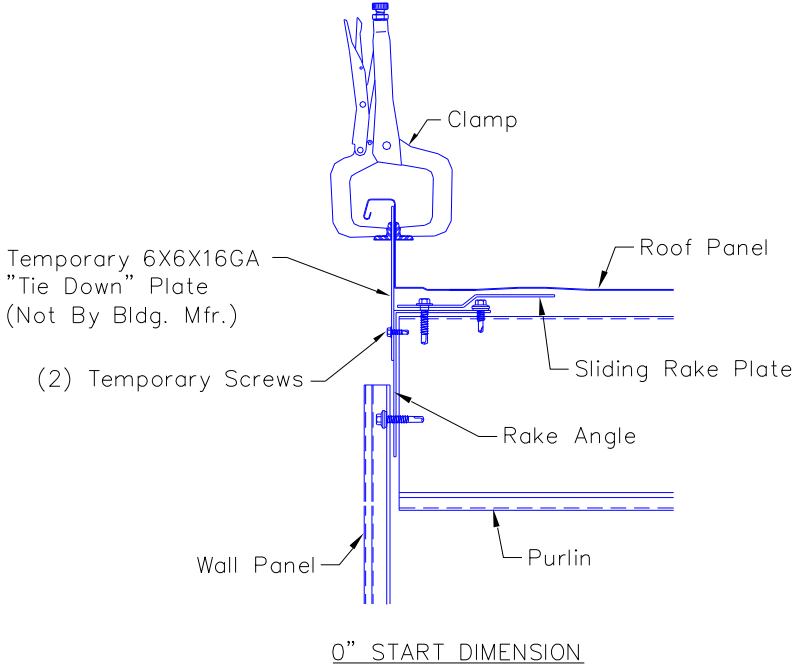

ZL-16® Roof System Installation Guide

9.5 CONSTRUCTING ENDLAPS

9.5.1 PANEL OVERHANG VERIFICATION

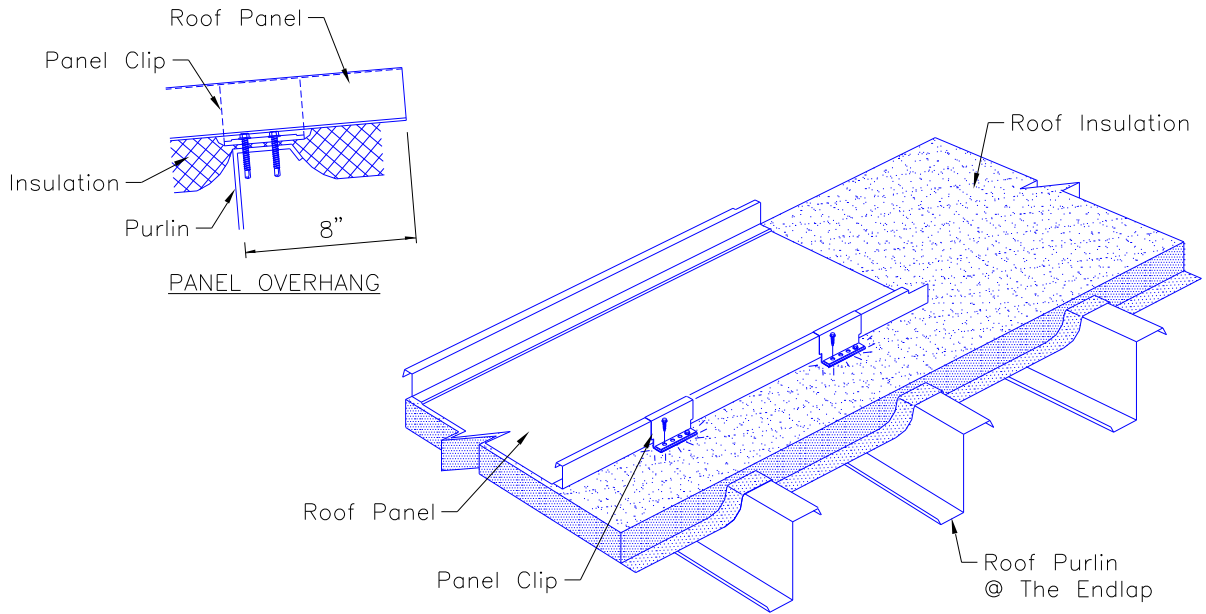

Verify that the roof panel overhang at the purlin line is 8". This dimension will assure that the back-up channel will clear the top of the purlin.

9.5.2 INSTALL TAPE AND GUN GRADE MASTICS

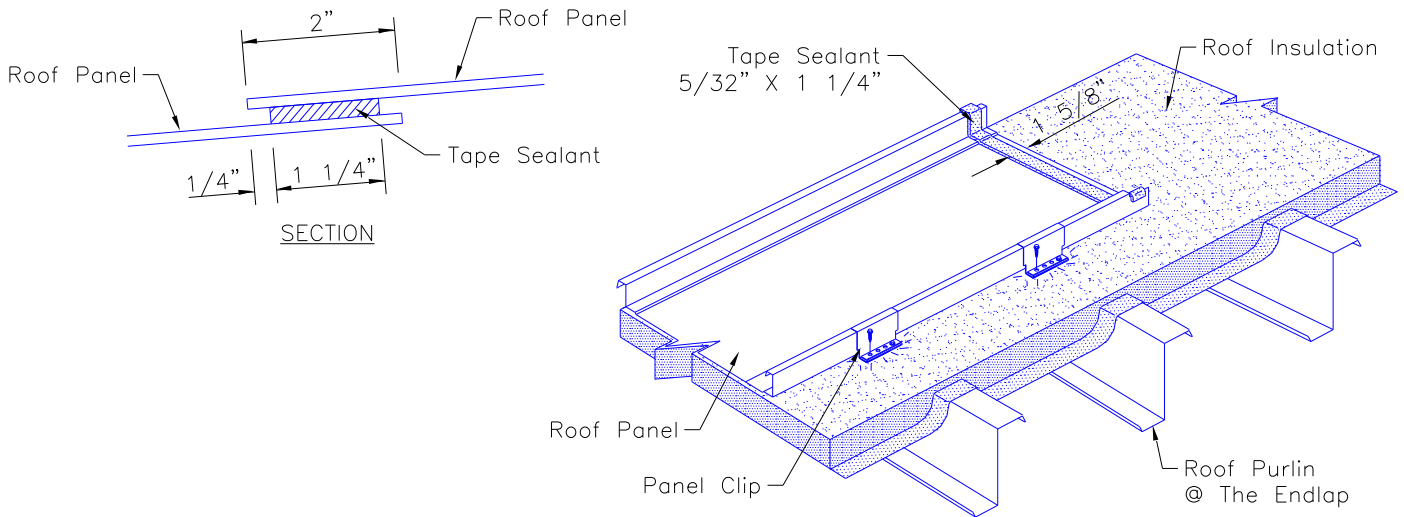

The proper placing of the tape sealant is critical to the weathertightness of the roof endlaps.

Before installing the tape sealant, the roof panel's surface must be wiped clean and dry.

Position the sealant so that its downslope edge is uniformly 1 5/8" from the end of the panel.

ZL-16® Roof System Installation Guide

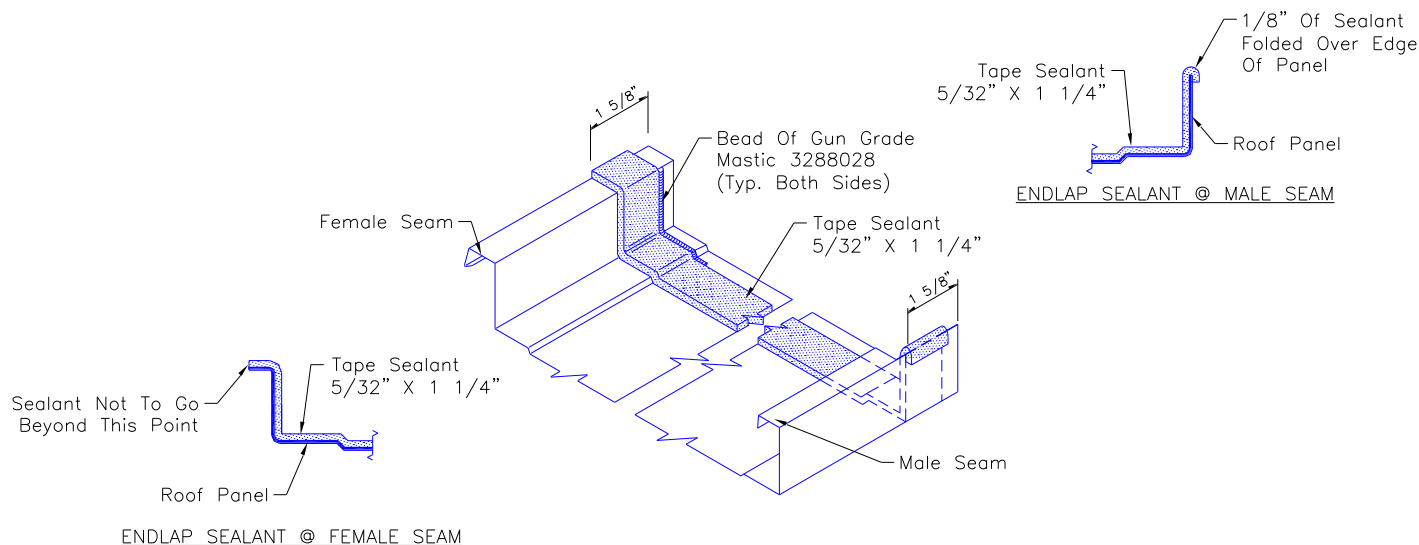

Install a continuous strip of tape sealant along the end of the roof panel, as shown. Check that the sealant fully contacts the roof panel's surface and that it is completely fitted into the panel corners and around the seams. Check that the 1/8" end of the sealant is correctly folded around the roof panel's edge on the male seam. Excess sealant in the roof panel seams will cause difficult panel assembly. Remove any excess sealant. After the sealant is correctly positioned, uniformly press the sealant against the roof panel's surface to assure adhesion. Do not use excess pressure which can thin the sealant.

The sealant's protective paper helps to retain the sealant's shape during installation and protects the sealant's surface from damage and contamination. Do not remove the protective paper until immediately before the installation of the upslope roof panel.

A bead of 3288028 gun grade mastic will be placed at each vertical rib location before proceeding with the placement of the "upslope" roof panel.

ZL-16® Roof System Installation Guide

9.5.4 PANEL ALIGNMENT

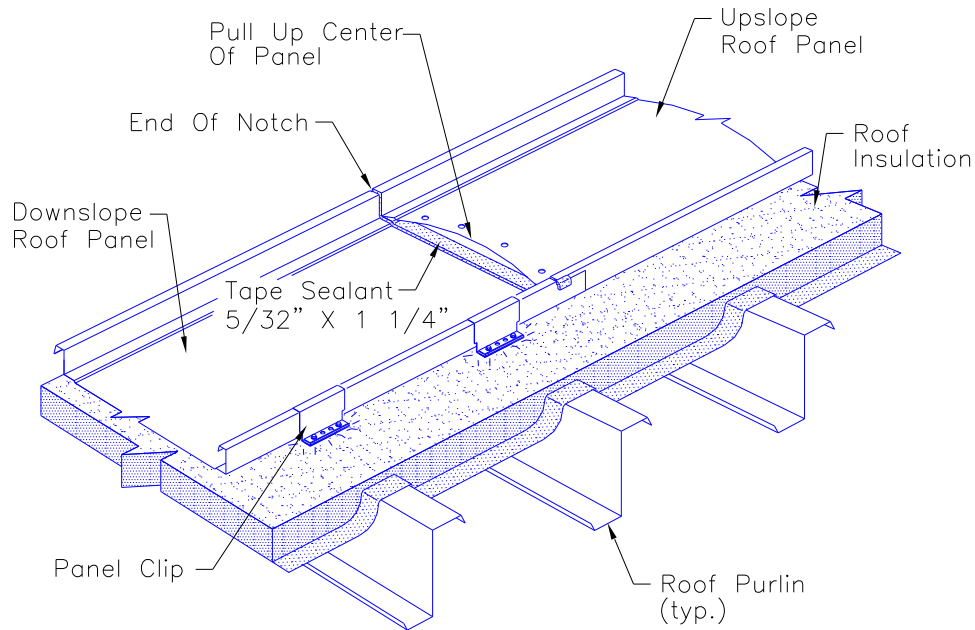

Caution
While setting the roof panel,
Do not wipe the endlap sealant
off the sides of the panel.

Lower the up-slope roof panel to lap onto the down-slope roof panel.

While lowering the up-slope roof panel, bow the end of the panel by pulling up on its center. This will allow the panel to more easily nest into the down-slope panel.

Do not displace or damage the sealants while nesting the upslope roof panel.

ZL-16® Roof System Installation Guide

9.5.5 CLAMP THE SEAMS

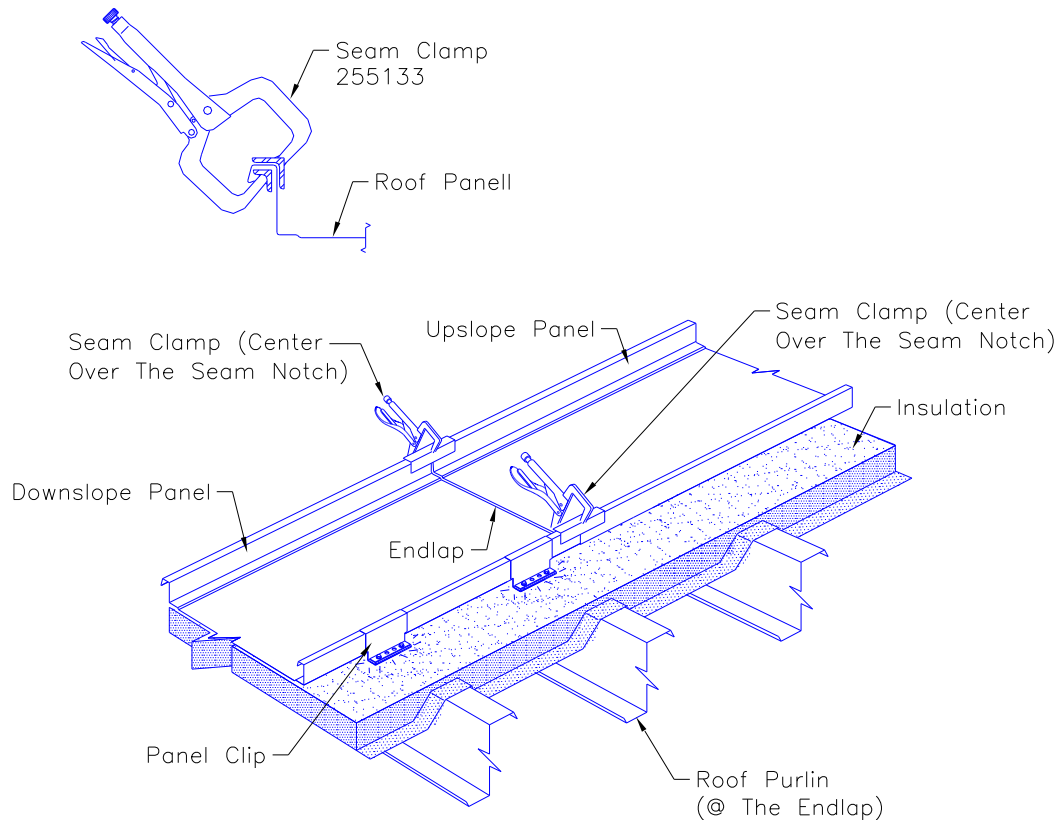

Use the seam clamps to draw the lapping panel seams together, as shown.

Check that the clamp jaws are correctly aligned to the seam before closing the clamp. Misaligned clamps can distort and damage the roof panel seams.

Slowly close the clamp to allow the sealant to flow between the lapped seams.

With the seam clamps installed, uniformly press down on the up-slope panel to close the panel lap and to assure adhesion of the endlap sealant.

Do not remove the seam clamps until after the fasteners have been installed in the endlap.

ZL-16® Roof System Installation Guide

9.5.6 INSTALL BACK-UP CHANNEL

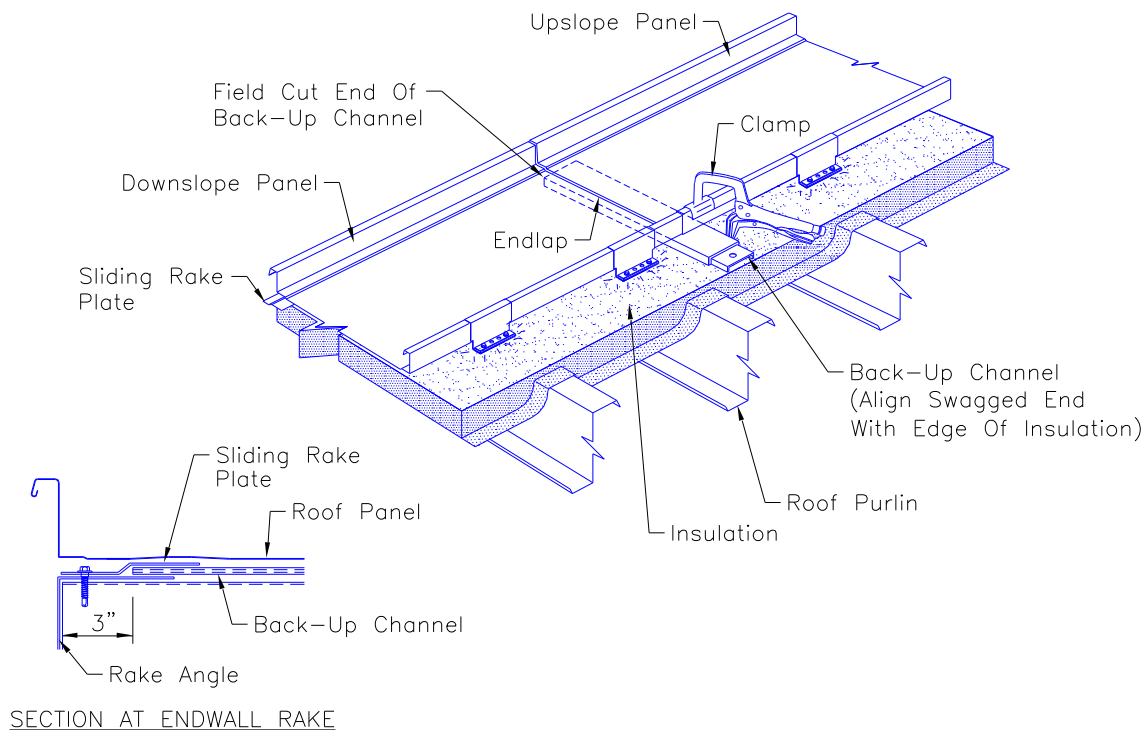

Field cut the starting back-up channel length to be equal to the width of the starting run of roof insulation. The cut-off must be the opposite of the swagged end.

Slide the back-up channel under the roof panel (endlap) and on top of the roof insulation stopping approx 3" short of the rake angle. Position the back-up channel so that the cut end is under the sliding rake plate. Position the back-up channel so it is centered under the roof panel endlap.

Check that the swagged end of the back-up channel is flush with the leading edge of the roof insulation.

Clamp the back-up channel to the leading edge of the roof panel. Position the clamp at the edge of the channel, so the clamp will not interfere with the installation of the (optional) cinch strap and /or end lap fasteners. Check that the clamp is bearing on the flat of the roof panel, not on the panel's shoulder rib.

ZL-16® Roof System Installation Guide

9.5.7 INSTALL ENDLAP FASTENERS

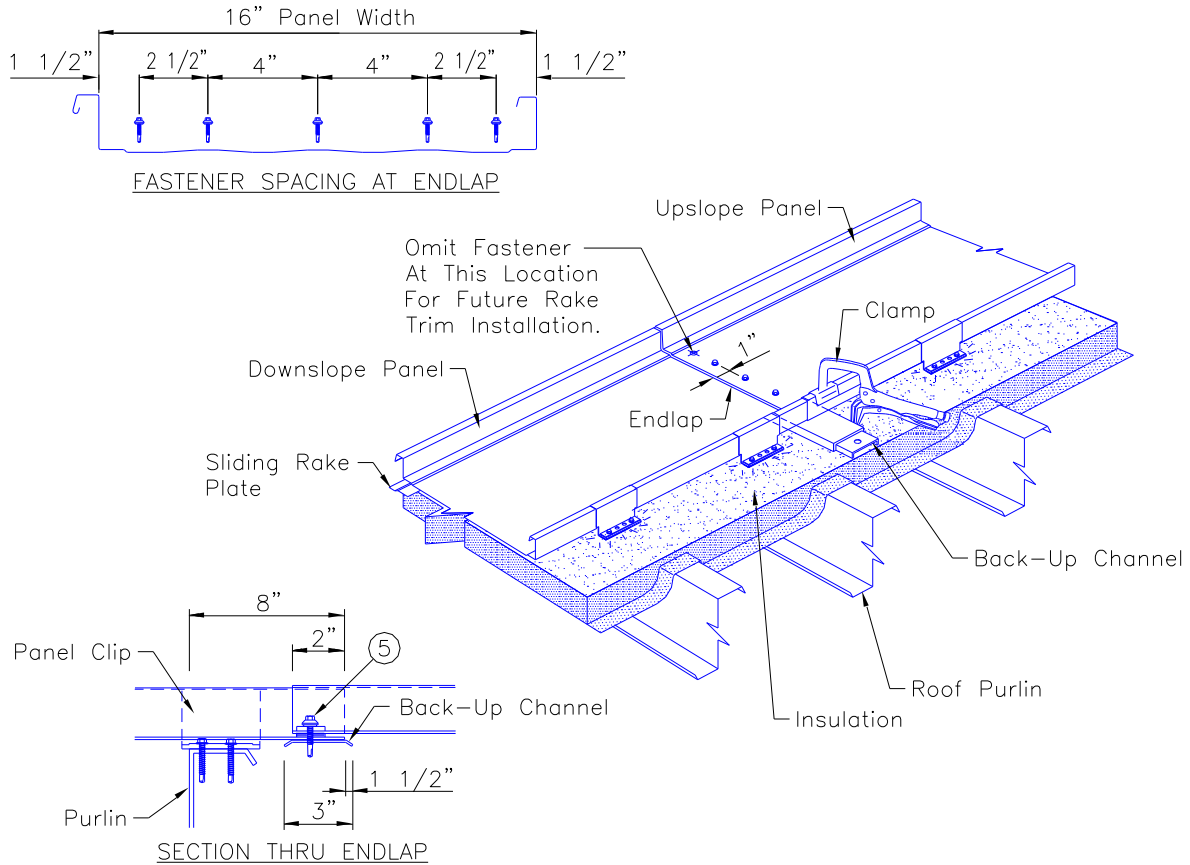

Install the ⑤ self-drilling screws at 1" from the panel end. Refer to the detail above for correct fastener spacing. Install fasteners at each side of the roof panel first, then install the remaining fasteners through the panels into the back-up channel.

Check that the fasteners penetrate through the center of the tape sealant and are securely engaged into the back-up channel.

Should any of these fasteners, during installation, be "overturned" or "stripped-out" they should be replaced with a # 17x1" self-tapping screw, see page 17. Leaving a stripped-out fastener will compromise the watertightness of the roof.

If the (optional) cinch strap is used see next page.

ZL-16® Roof System Installation Guide

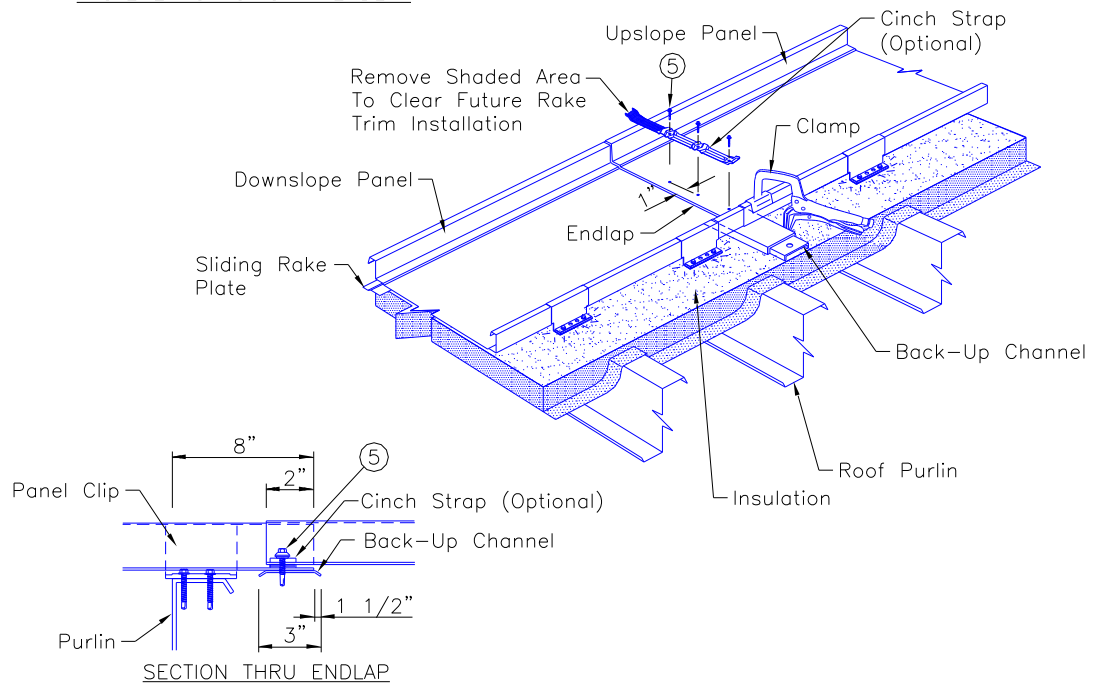
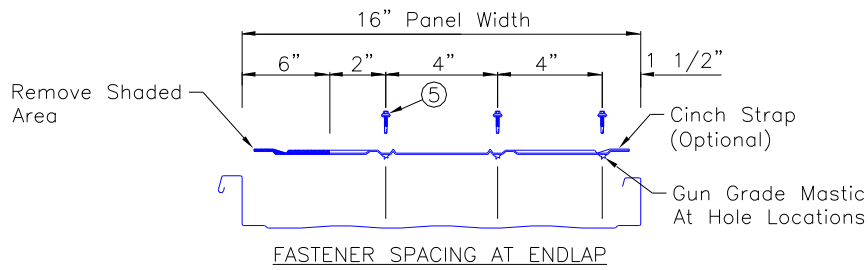

When the (optional) cinch strap is used, remove the shaded area (see above) and apply gun grade mastic 3288028 to the bottom of the cinch at the hole locations. Position the cinch strap so that the 3 fasteners are 1" from the panel end and when installed will pass through the tape mastic and securely engage into the back-up channel.

Should any of these fasteners, during installation, be "overturned" or "stripped-out" they should be replaced with a #17x1" self-tapping screw, see page 17. Leaving a stripped-out fastener will compromise the water tightness of the roof.

ZL-16® Roof System Installation Guide

9.6 PIGTAIL SEALANTS ALONG PANEL SEAM

9.6.1 LOCATION OF PIGTAILS

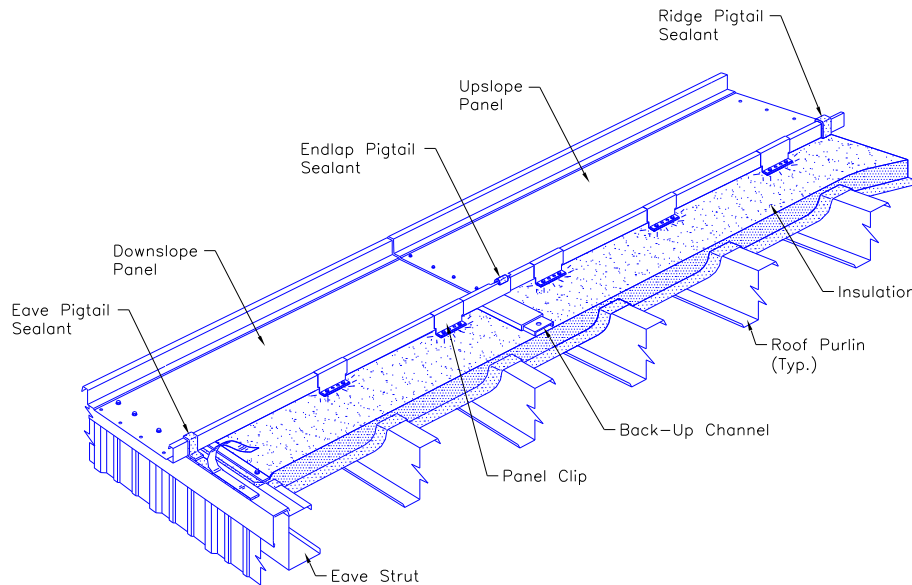

Pigtail sealants are strips or pieces of tape sealant, cut to the required length from rolls of tape sealant. Use a box knife or scissors to cut pig tail sealants.

The pigtail sealants must be correctly installed along the panel seam, before the next panel run can be installed.

Install the EAVE, ENDLAP and END DAM pigtails on the leading edge of the roof panel as shown.

9.6.2 PIGTAIL SEALANT AT EAVE

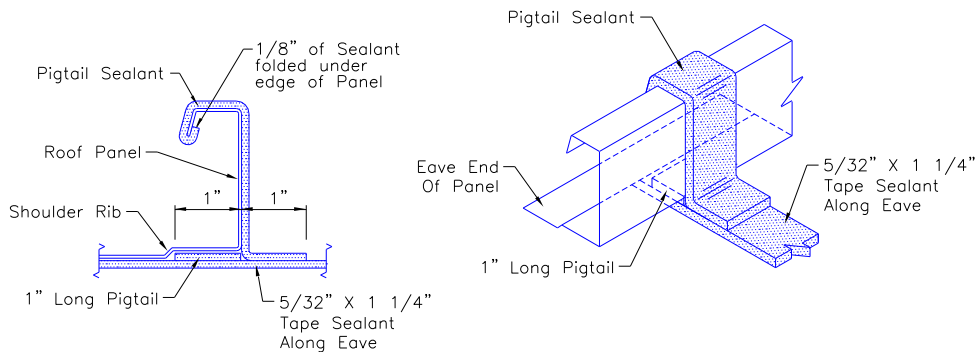

Cut two pigtail sealants, from a roll of 5/32"x11/4" tape sealant that will be fitted around the roof panel's seam as shown.

A 1" long pad of sealant will be used under the panel's shoulder rib. Then lap 1" of the second pigtail sealant onto the tape sealant along the eaveline. Cut the other end of the pigtail sealant so 1/8" can be folded under the edge of the roof panel.

After the pigtail sealant is correctly placed, uniformly press the sealant against the panel's surface to assure adhesion.

8/29/08

ZL-16® Roof System Installation Guide

9.6.3 PIGTAIL SEALANT AT ENDLAP

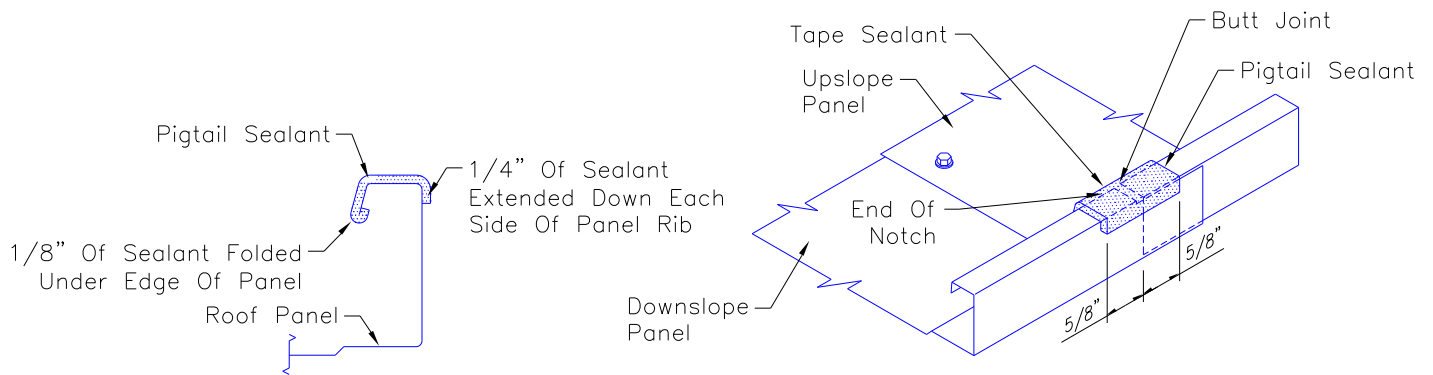

Cut the pigtail sealant to a 2" length, from a roll of 5/32"x1 1/4" tape sealant, to fit around the roof panel's seam as shown.

Position the pigtail sealant to lap 1/2" beyond each end of the roof panel's notch.

Center the sealant over the roof panel's seam. Fold the edges of the sealant down over the sides of the seam.

Excess sealant in the seams will cause difficult roof panel assembly. Remove any excess sealant.

After the pigtail sealant is correctly placed, uniformly press the sealant against the panel's surface to assure adhesion.

9.6.4 PIGTAIL SEALANT AT RIDGE OR HIGH EAVE END OF PANEL

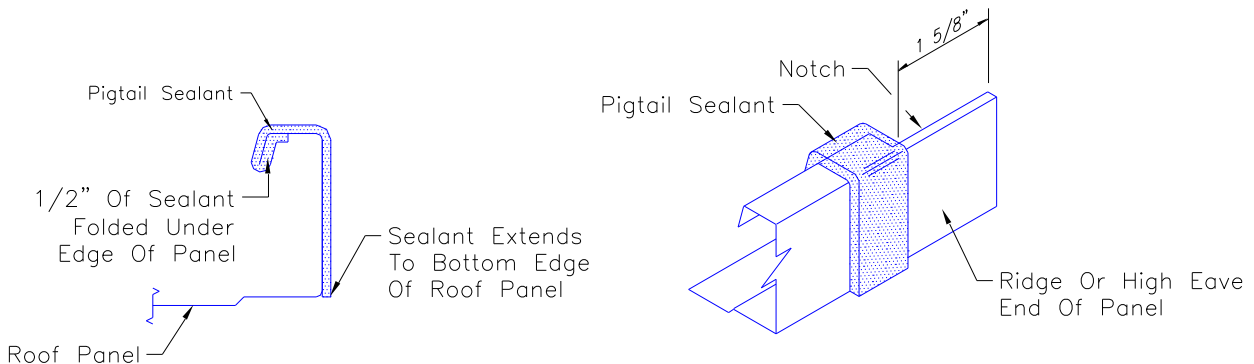

Cut the pigtail sealant, from a roll of 5/32" x 1 1/4" tape sealant and position the pigtail between the roof panels at the notched area.

Position the pigtail sealant so its edge is 1 5/8" from the end of the roof panel. The sealant must lap over the edge of the roof panel notch.

Fold 1/2" of the ridge pigtail sealant under the edge of the roof panel. Cut the other end of the sealant so it sets flush with the bottom edge of the roof panel's seam.

Excess sealant in the seams will cause difficult roof panel assembly. Remove any excess sealant.

After the pigtail sealant is correctly placed, uniformly press the sealant against the panel's surface to assure adhesion.

ZL-16® Roof System Installation Guide

9.7 INSTALL NEXT PANEL RUN

Prior to installing next panel run install a back-up channel at each panel endlap location. If no endlap exists proceed to Section 9.7.2 for engaging panel side lap.

9.7.1 INSTALLING BACK-UP CHANNEL AT ENDLAP

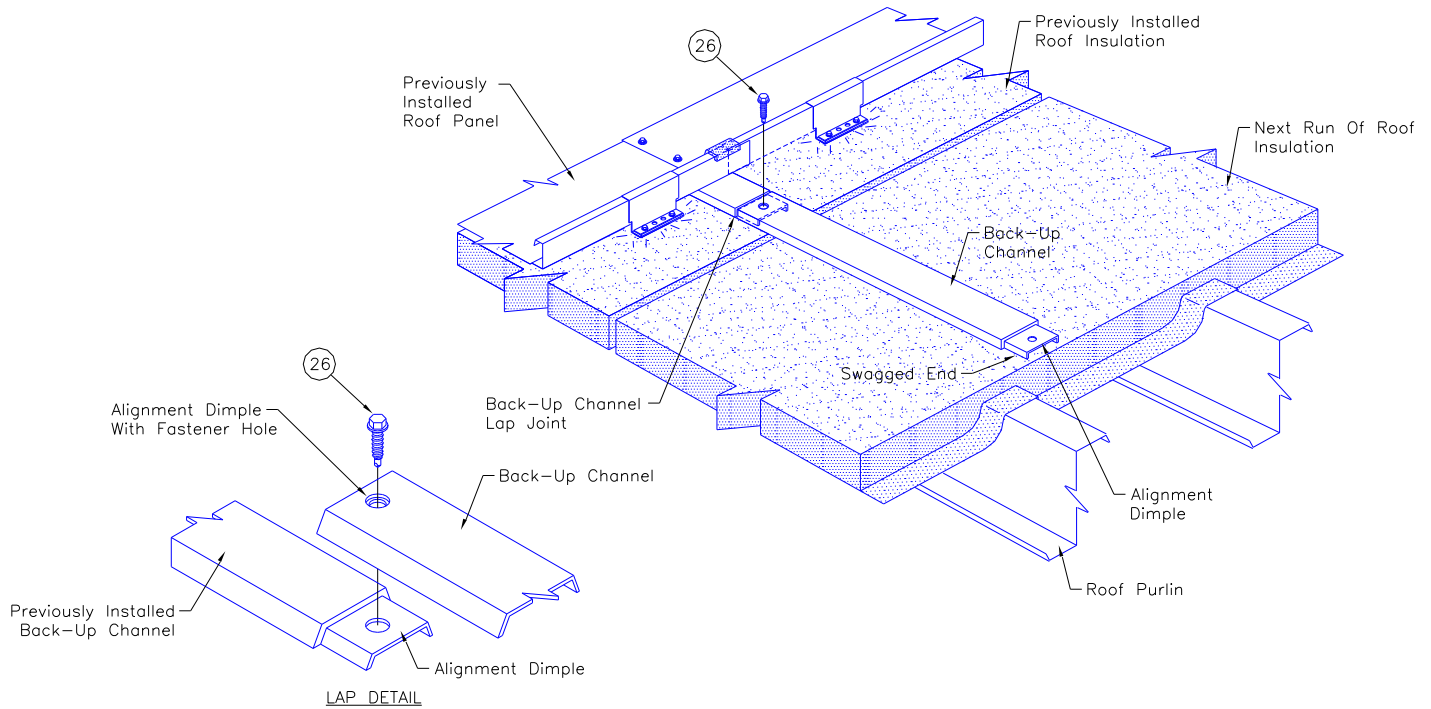

After the next run of roof insulation is in place set the next back-up channel on top of the roof insulation. Position the back-up channel so its non-swagged end laps over the swagged end of the previously installed back-up channel. Check that the back-up channel ends and their alignment dimples are fully nested together.

Position the back-up channel's swagged end so the channel will be centered and parallel to the next roof panel endlap.

Secure the back-up channels together with a (26) 1/4" x 1" self-drilling screw installed through the factory-punched hole in the alignment dimple of the overlapping channel. Check that the fastener fully engages the underlying back-up channel.

ZL-16® Roof System Installation Guide

9.7.2 ENGAGING PANEL SIDELAP

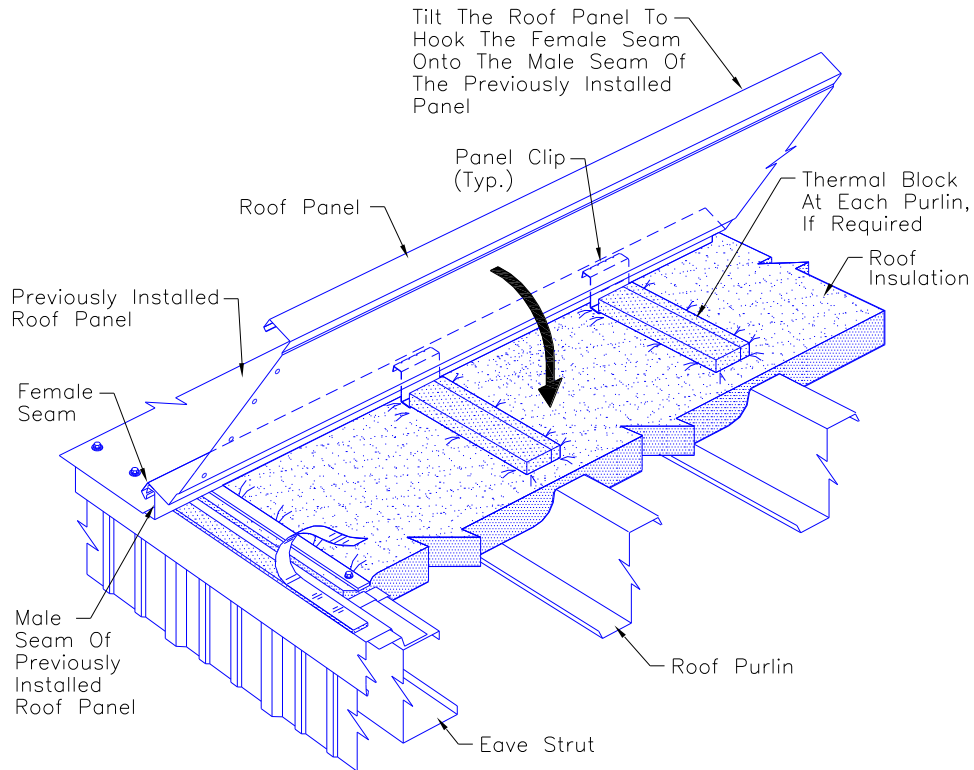

Remove the protective paper from the tape sealant. Remove only enough of the protective paper to allow installation of the next roof panel.

If required, place the thermal blocks on top of the insulation directly over the roof purlin. On some roof slopes it may be advantageous to use a spray-on adhesive on the thermal block to keep it positioned above the roof purlin until the panel is installed.

Position the trailing edge of the roof panel over the leading edge of the previously installed roof panel and position the end of the roof panel 4" beyond the eave strut unless another dimension is specified on the erection drawings. Tilt the panel as shown so the female seam can be hooked over the male seam of the previous roof panel.

Specific roof panel sidelap assembly details are shown on the following page.

ZL-16® Roof System Installation Guide

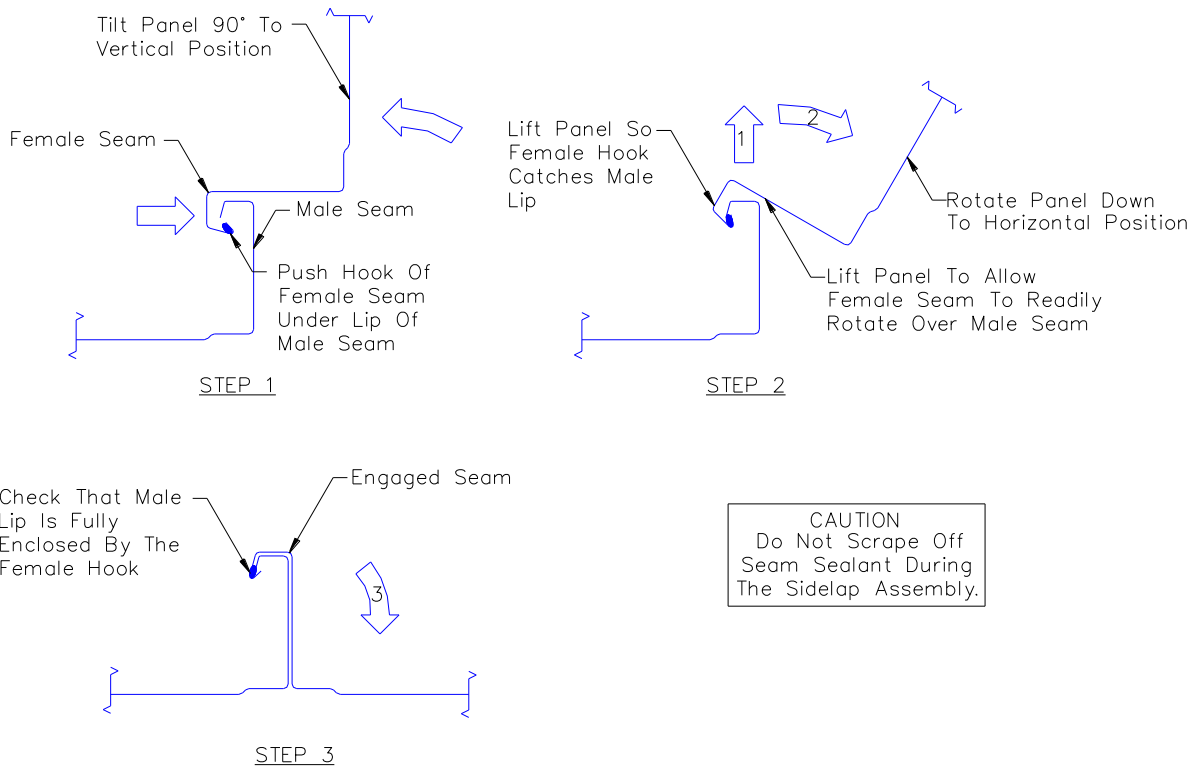

It is easier to hook the roof panel seams together if the roof panel is first tilted up to the vertical position.

With the roof panel in the vertical position, align its female seam to slide under the male seam of the previous roof panel.

With female seam under the male seam, lift up the roof panel, so the female seam's hook catches the lip of the male seam. While continuing to lift up on the roof panel, rotate down to rest on the insulation or thermal blocks. Be careful not to scrape off the seam sealant during the sidelap assembly.

Check that the female hook has enclosed the male lip along the entire length of the panel. If not, the panel sidelap must be correctly reassembled before installing the next roof panel.

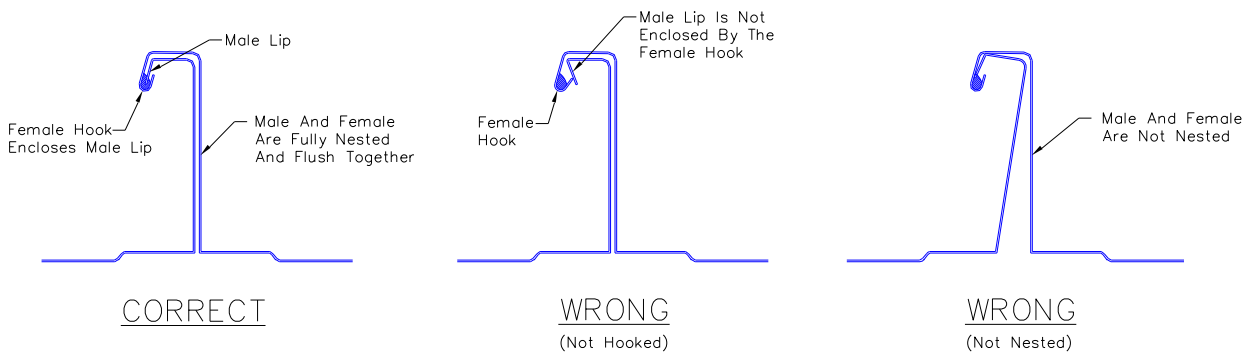

CAUTION: A false seam may occur where the female lip does not hook the roof panel's male lip. False seamed roof panels cannot provide their designed loads and maintain the weather tightness resistance. They must be reassembled before installing the next roof panel.

ZL-16® Roof System Installation Guide

9.8 END DAM INSTALLATION

9.8.1 ORIENTATION VIEW

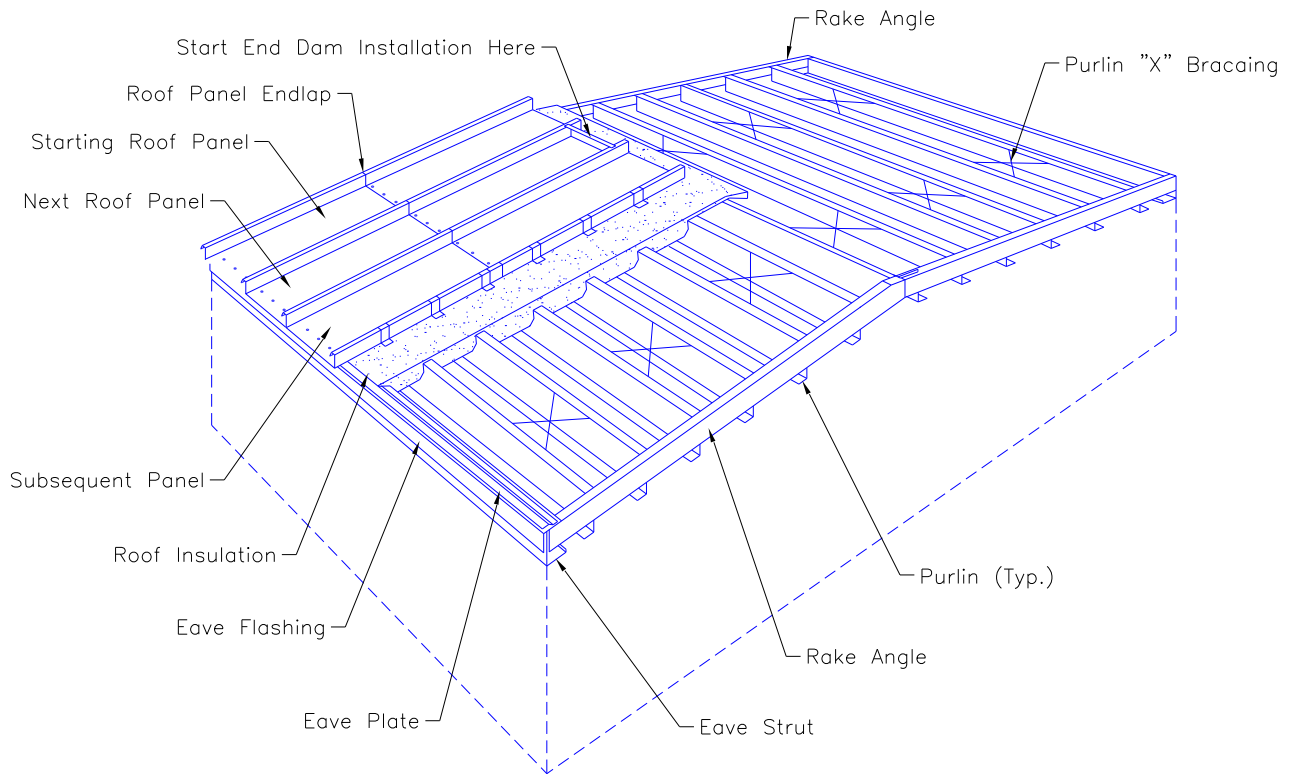

Metal end dams are used to close the ends of the roof panels at the ridge, high eave and high eave transition conditions. The details in this section will show roof panel preparation requirements and installation of the end dams.

The end dam for the starting roof panel will ONLY installed after the rake trim is installed.
The end dam should be installed in a panel run AFTER the next panel run has been installed.

Installation of end dams as each panel run is completed helps to maintain the correct roof panel coverage at the ridge or high eave.

If the end dams are installed after all of the roof panels are in place, roof panel coverage errors may prevent proper installation of the end dams.

8/29/08

ZL-16® Roof System Installation Guide

9.8.2 PREPARATION FOR END DAM INSTALLATION

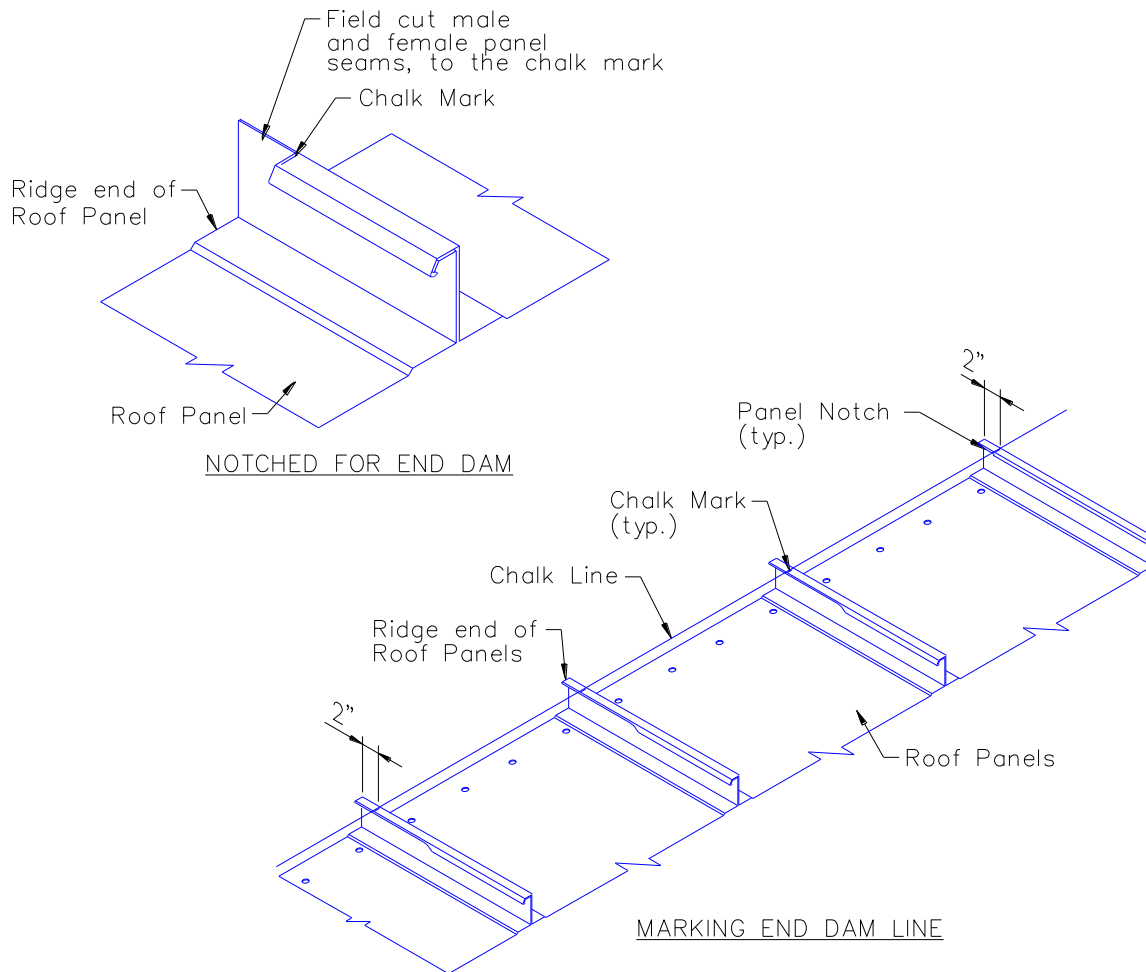

Verify that the roof panel overhang at the (ridge) purlin line is sufficient to complete the ridge or high eave trim detail. See "Panel Overhang Verification" in Section 9.4.3

Check the alignment of the notches/end dams along the ridge line. If the notches/end dams are staggered more than $\frac{1}{4}$ ", use a chalk line to establish a straight line. Position the chalk line so no notch extends below the line.

Using the end of the factory notch (or chalk marks) as a guide, field cut the additional notching in both male and female portions of the seam as shown.

ZL-16® Roof System Installation Guide

9.8.3 INSTALL BACK-UP CHANNEL

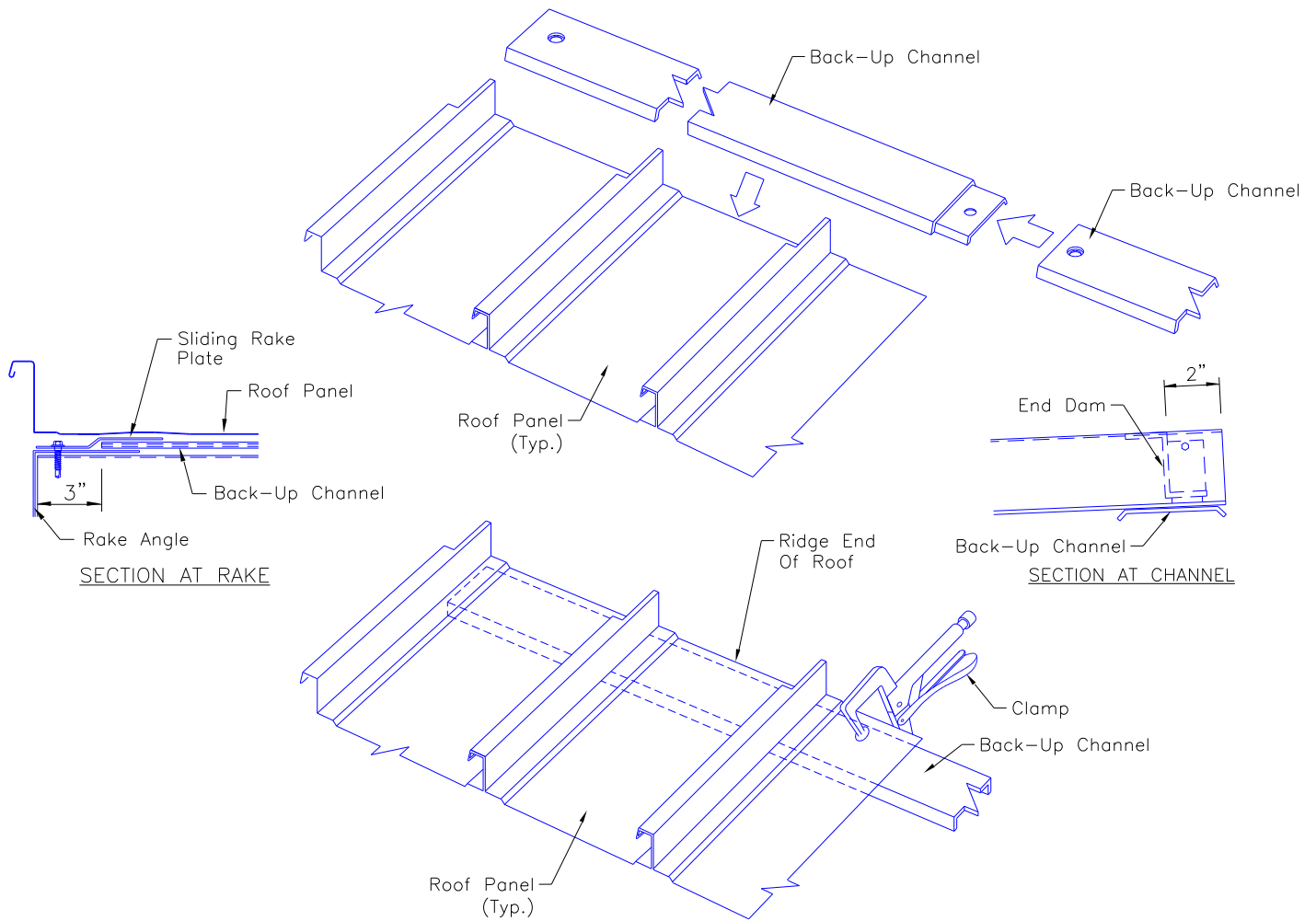

At the ridge or high eave, the back-up channels do not require fastening together as is done at the roof panel endlaps.

Field cut the starting back-up channel length to be equal to the width of the starting run of roof insulation. The cut-off must be the opposite of the swagged end.

Slide the back-up channel under the roof panel and on top of roof insulation stopping approx 3" short of the rake angle. Position the back-up channel so that the cut end is under the sliding rake plate. Position the back-up channel so it is centered under the end dams.

Check that the swagged end of the back-up channel is flush with the leading edge of the roof insulation.

Clamp the back-up channel to the leading edge of the roof panel. Position the clamp at the edge of the channel, so the clamp will not interfere with the installation of the end dam and its fasteners.

ZL-16® Roof System Installation Guide

9.8.4 INSTALLING TAPE AND GUN GRADE MASTICS

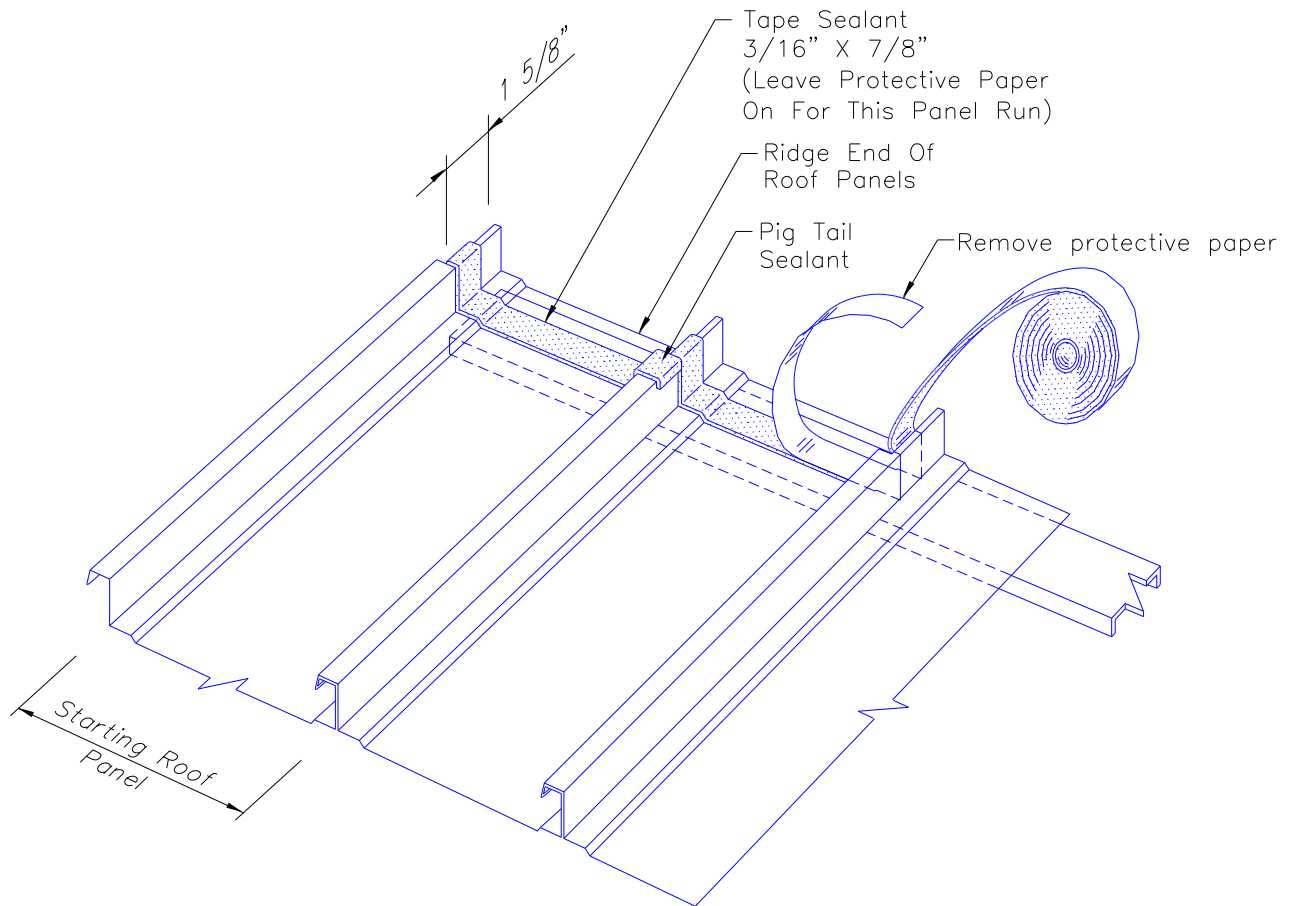

Before installing the tape sealant, the roof panel's surface must be wiped clean and dry.

Install a continuous strip of tape sealant along the end of the roof panel as shown.

Position the sealant so that its downslope edge is uniformly 1 5/8" from the end of the panel.

Check that the sealant fully contacts the roof panel's surface and that it is completely fitted into the panel corners and around the seams

Cut a strip of flashing sealant and install as the pigtail sealant as shown. Use a box knife or scissors to cut pigtail sealants.

The protective paper should be left on the tape sealant, on the starting roof panel, as this end dam will be installed AFTER the rake trim is installed.

Specific tape sealant details are shown on the following page.

ZL-16® Roof System Installation Guide

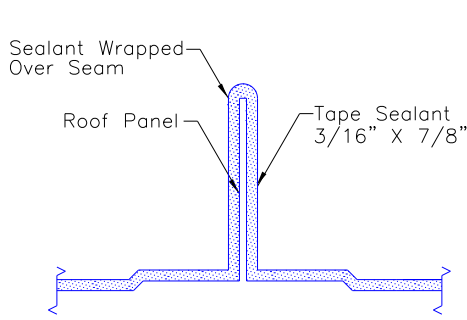

3/16" X 7/8" TAPE SEALANT
AT RIDGE OR HIGH EAVE

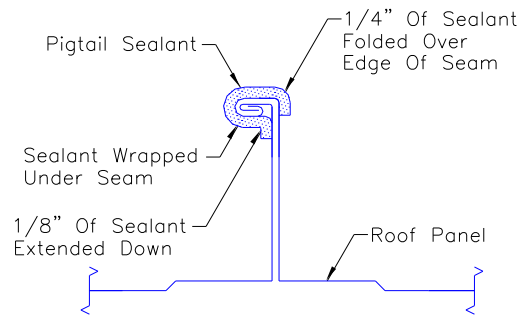

PIGTAIL SEALANT
AT RIDGE OR HIGH EAVE

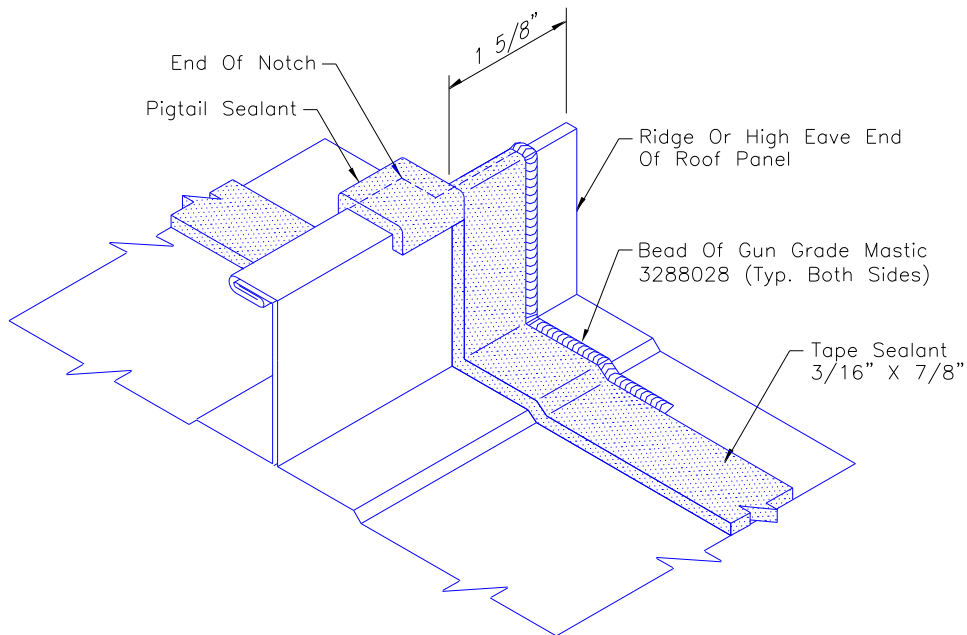

The correct installation of the ridge sealant is critical to the weather resistance of the roof system.

Be sure to verify that the sealant is installed as shown above before installing end dams.

After the sealant is correctly positioned, uniformly press the sealant against the roof panel's surface to assure adhesion. Do not use excess pressure, which can thin the sealant.

ZL-16® Roof System Installation Guide

9.8.5 INSTALL END DAM

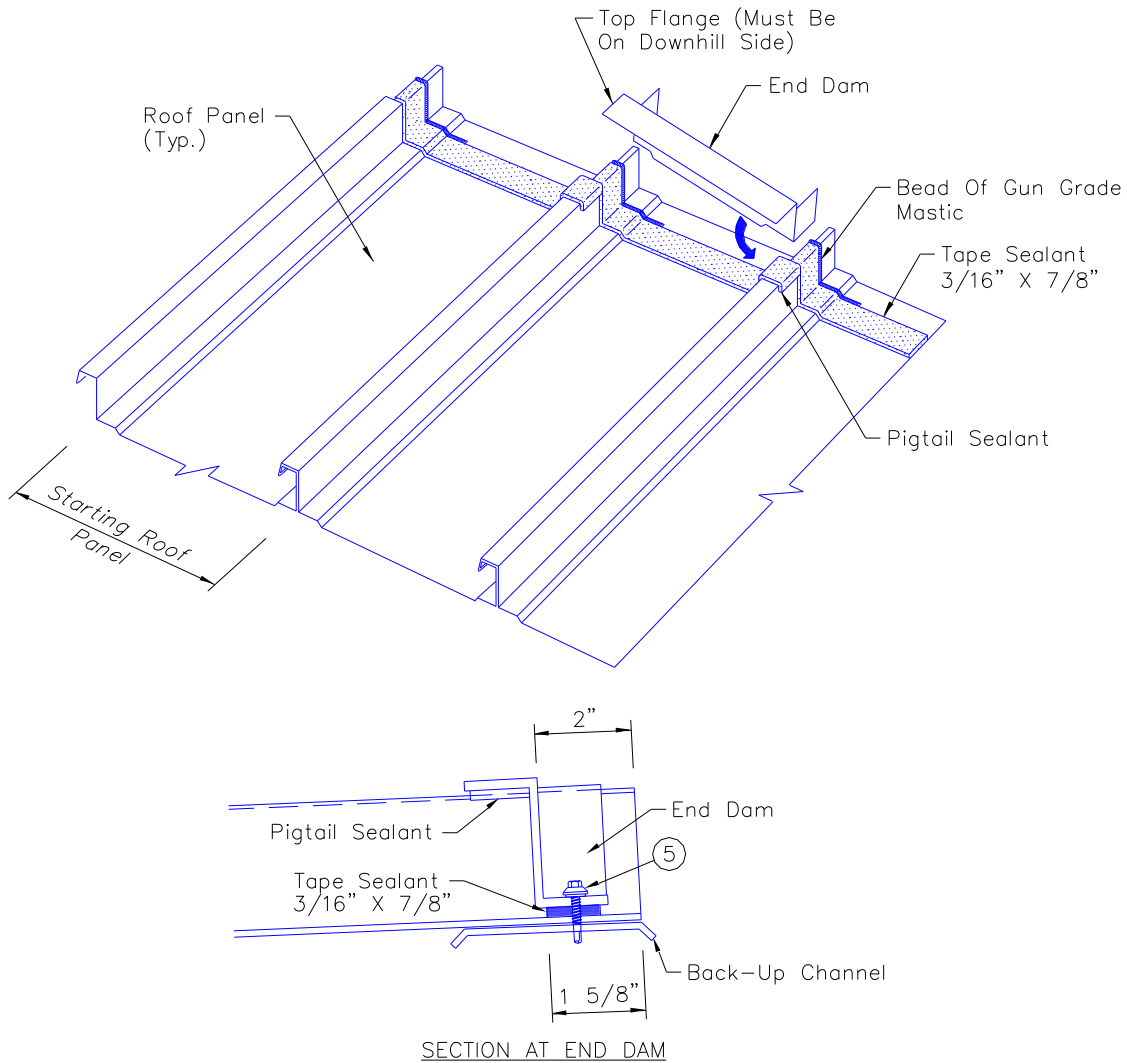

Wipe dry and clean the underside surface of the end dam flanges.

Remove the protective paper from the installed tape sealant where end dam will be installed.

A bead of 3288028 gun grade mastic will be placed at each vertical rib location before proceeding with placement of the end dam.

Position the end dam so its bottom flange is turned up-slope and its top flange is downslope.

Position the end dam's bottom flange directly over the tape sealant and its web located 2" from the panel end. Then, uniformly press the end dam into the tape sealant to assure adhesion. Use a clamp to hold the assembly together while installing the fasteners.

Be careful not to displace or damage the sealant while installing the end dam.

ZL-16® Roof System Installation Guide

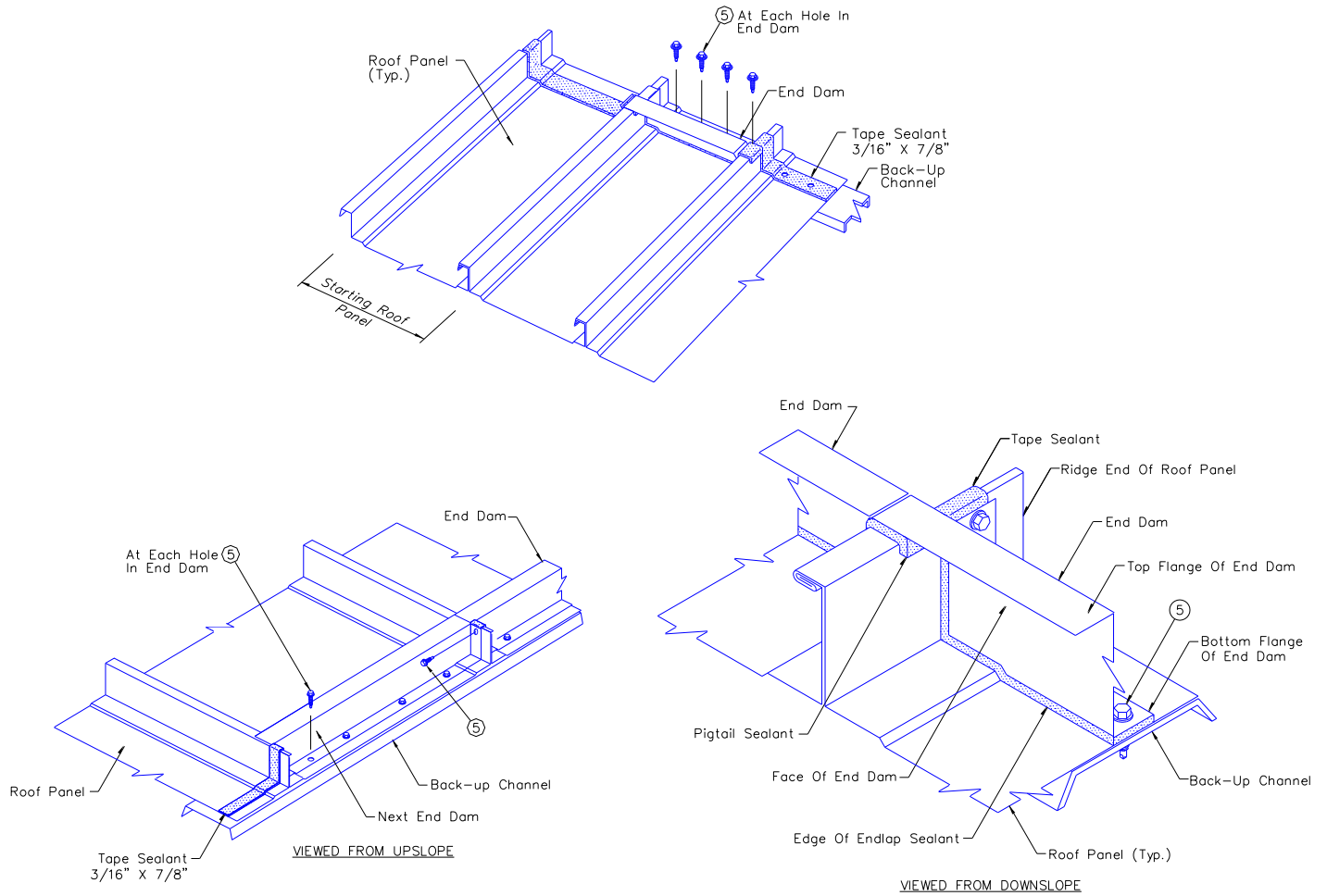

Install ⑤ self-drilling screws through the holes in the end dam's bottom flange.

Check that the screws penetrate through the center of the tape sealant and are securely engaged into the back-up channel.

Check that the face of the end dam is perpendicular to the roof panel and aligned with the previously installed end dams. If not, push the top of the end dam to the correct position.

Install ⑤ self-drilling screw through the top of the end dam, through the roof panel seam and into the opposite end dam. Over tightening this screw will squeeze the roof panel sidelap assembly together and may affect the roof panel's coverage width. Carefully tighten the screw only as necessary to maintain the correct panel width.

ZL-16® Roof System Installation Guide

9.9 INSTALLING SUBSEQUENT PANEL RUNS

9.9.1 CHECKING PANEL COVERAGE

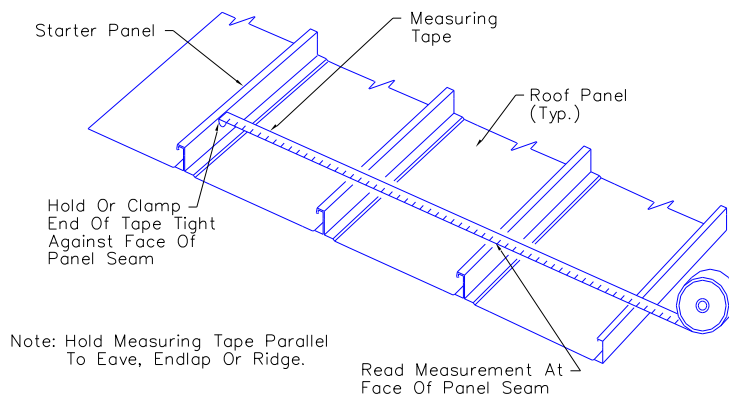
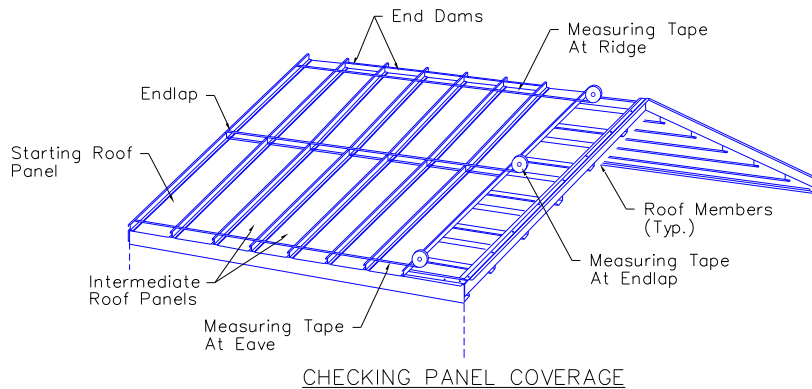

CAUTION: To assure proper fit-up of the sidelap assembly, proper seaming and proper fit-up of end dams, roof curbs etc. it is important that each panel be held within the 1/16" panel coverage tolerance and that overall coverage be checked frequently and any coverage error be corrected before it accumulates.

Coverage must be checked at eave, ridge and at every endlap.

To avoid accumulation error, the coverage measurement should always be from the rake line or the starting roof panel's seam.

To avoid measurement error, the measuring tape must be free and taut and must be parallel to the eave line or ridgeline.

ZL-16® Roof System Installation Guide

9.9.2 ADJUSTING PANEL COVERAGE

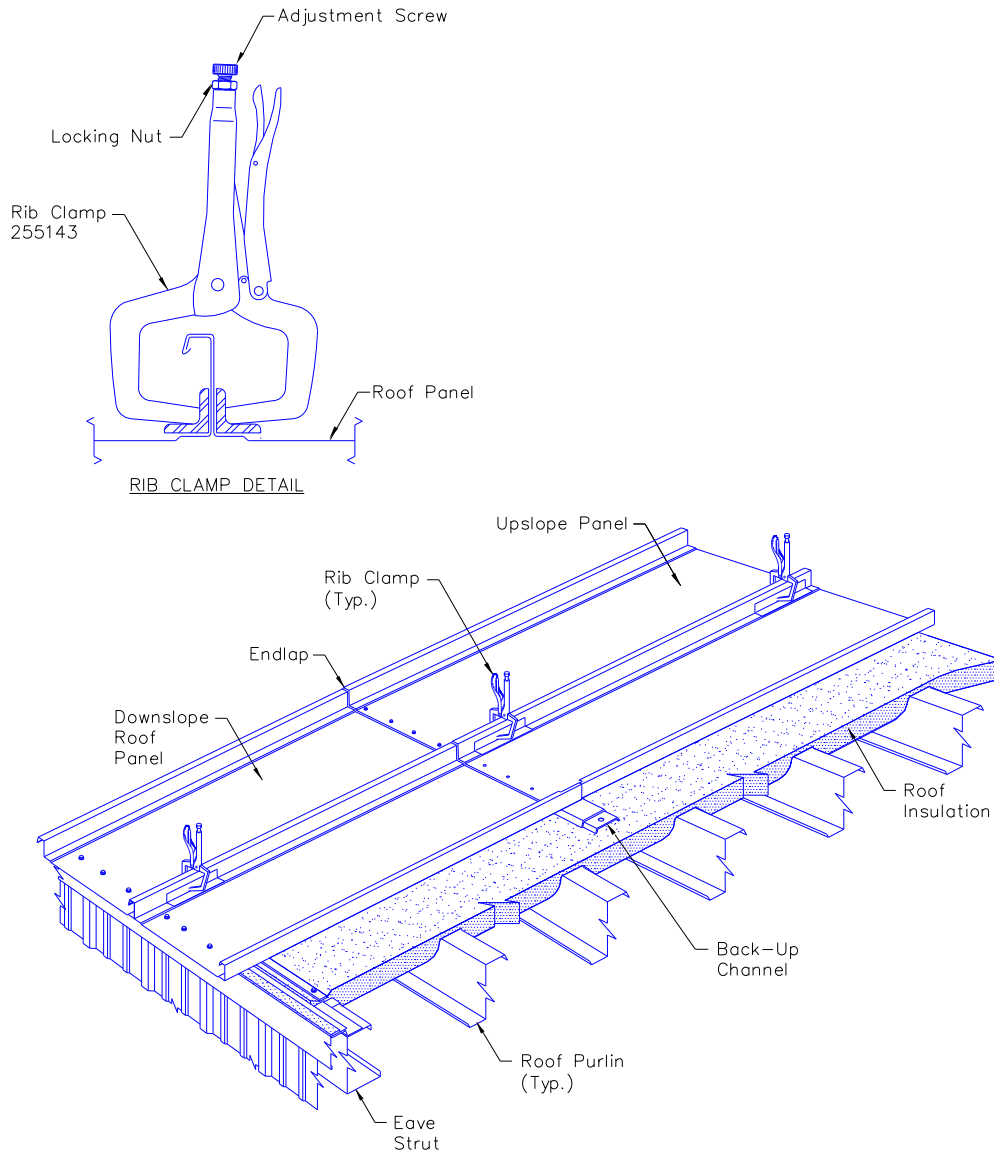

The most common coverage error is the spreading of the roof panel sidelaps, especially at the panel ends. This can cause excess panel coverage along the eave, endlaps and ridge.

Before installing the next run of panel clips, use rib clamps to squeeze together the previous sidelap. Slowly close the clamp to allow the sealant to flow between the lapped seams.

The rib clamps can be adjusted and locked so that they will squeeze the panel ribs to provide a consistent coverage width.

If excessive coverage has accumulated over several panel runs, do not try to correct all of the error at one time. Corrected roof panel coverage must not be greater than 1/16" per panel. Correct accumulated coverage error by making the correction over several panel runs.

ZL-16® Roof System Installation Guide

9.10 TERMINATION PANEL INSTALLATION

9.10.1 INSTALL LAST PANEL RUN

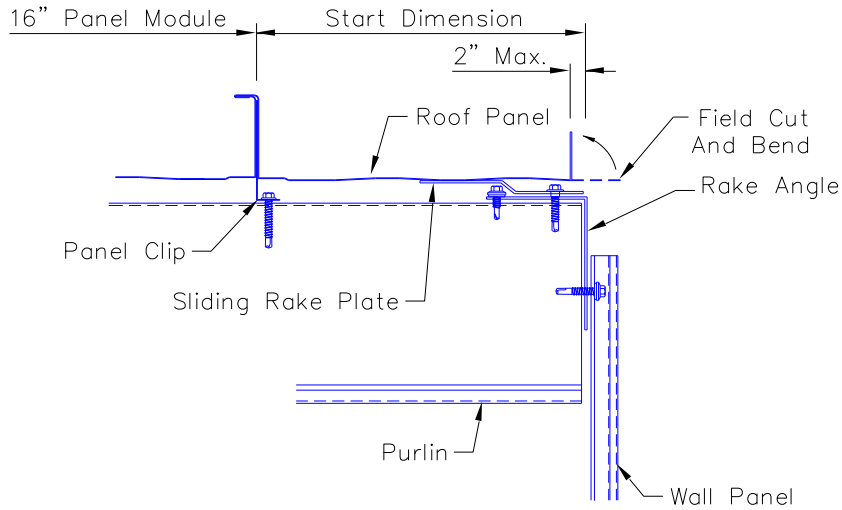

START DIMENSION GREATER THAN 0"

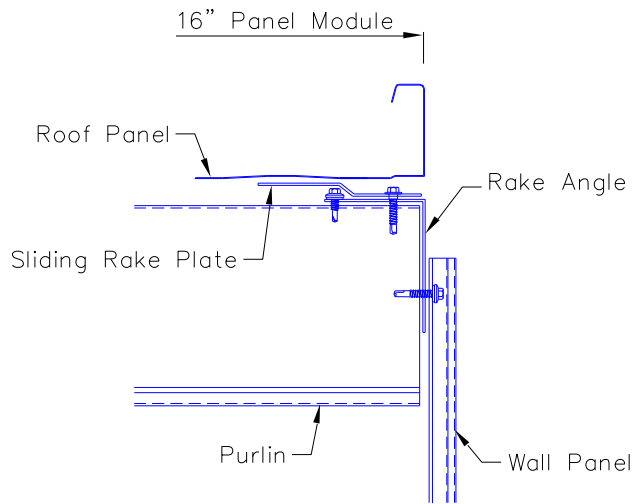

0" START DIMENSION

The position of the last panel in relationship to the endwall rake angle is critical. Check the erection set of plans for possible "START DIMENSION" and if field cutting of the last panel is required. If the panel is to be field cut, allow for a minimum 1" bent-up leg along the cut edge.

The last panel edge should not extend beyond the outer edge of the rake and no more than 2" short of the rake.

ZL-16® Roof System Installation Guide

9.11 RAKE TRIM INSTALLATION

9.11.1 ORIENTATION VIEW

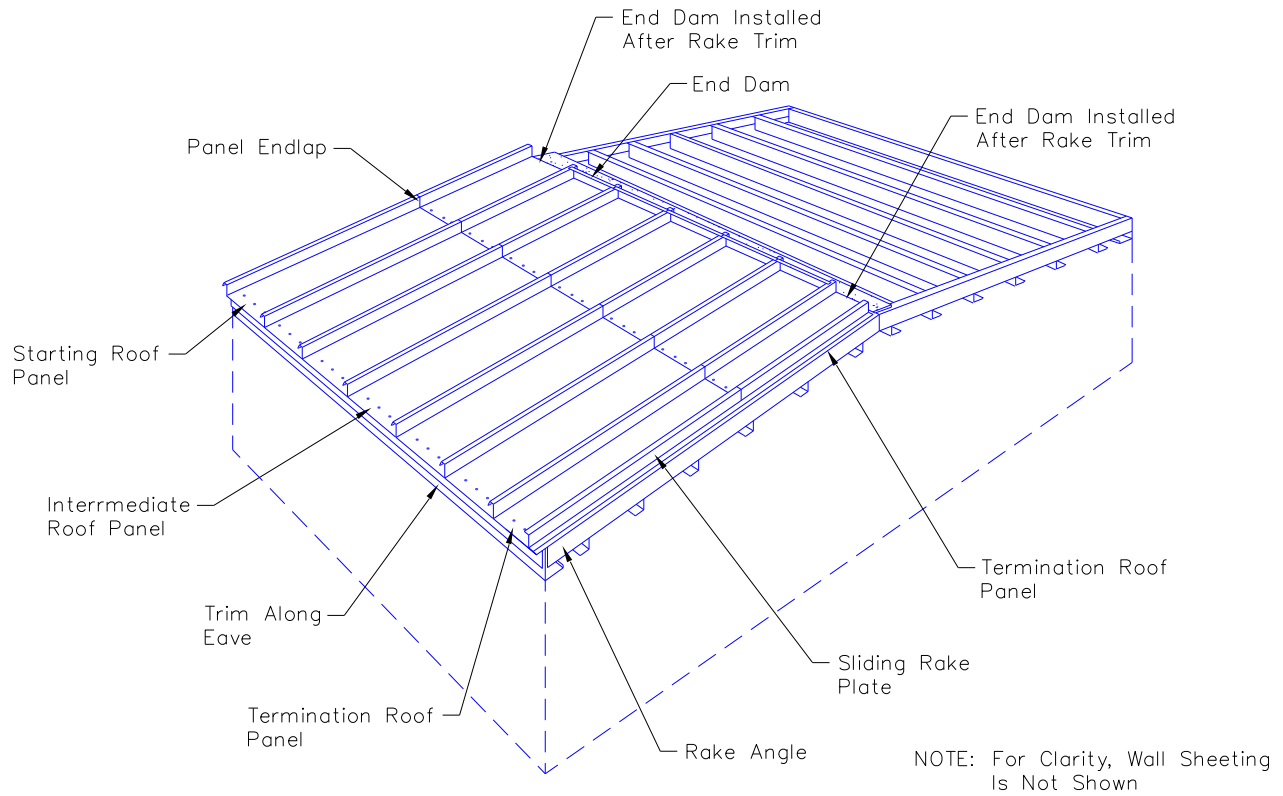

The details in this section show installation of rake trim along the last panel run, having a 0" start dimension.

This information can be applied to rake trim along the first panel run at the other endwall and/or roof panel runs with a start dimension greater than 0"

The end dams at the "starting" panel run and the "termination" panel run will be installed AFTER the rake trim is installed.

ZL-16® Roof System Installation Guide

9.11.2 INSTALL TAPE SEALANT ALONG RAKE

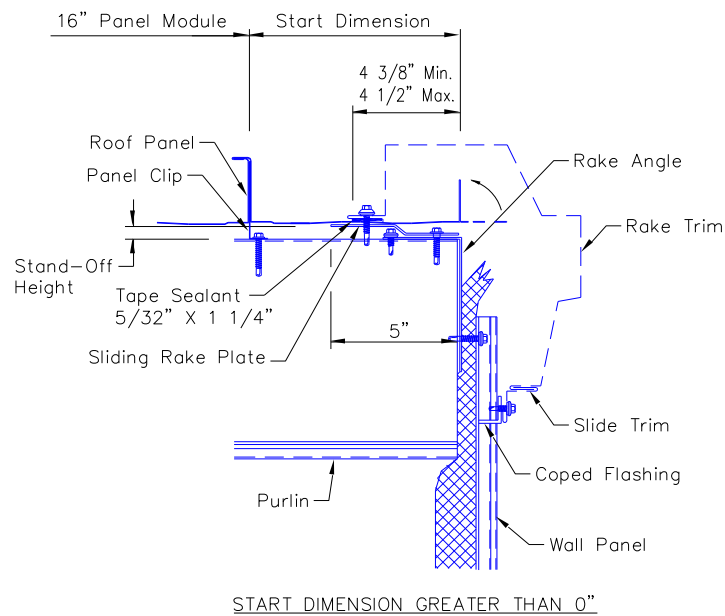
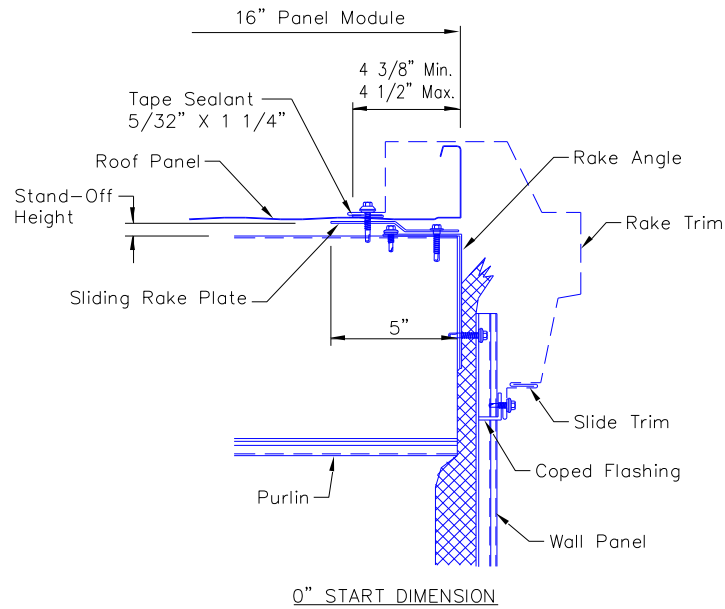

Prior to installing tape sealant along the endwall rake, wipe the top surface of the roof panel clean and dry. The tape sealant must be positioned directly over the sliding rake plate's top flange. Layout the sealant location on the panel's top surface with a chalk line.

Position the edge of the sealant on the chalk line. Start and finish the ends of the sealant flush with the ends of the roof panel.

Check the entire length of the sealant to assure that it is correctly positioned and that there are no voids or thinned areas.

After the sealant has been correctly installed, lightly press the sealant against the roof panel to assure adhesion. Do not use excess pressure which can thin the sealant.

8/29/08

ZL-16® Roof System Installation Guide

9.11.3 START RAKE TRIM AT EAVE

Prior to installing the first section of rake trim, position the rake trim at the corner, as shown below, to determine if and how much of the major rib on the panel extends beyond the end of the rake trim. Field notch or remove the MAJOR RIB on the panel so that the end cap can be installed later.

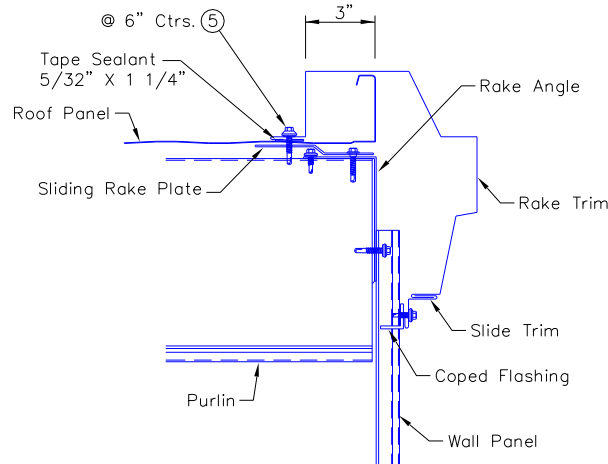

Remove protective paper from tape sealant and position lip on the rake trim over the sealant as shown above.

Start the downslope end of the rake trim and slide trim at the edge of the outside corner trim when eave trim or standard size gutter is used along the sidewall eave. When high capacity gutter is used along the sidewall eave, the rake trim should start at the end of the roof panel and the slide trim should start at the edge of the outside corner trim.

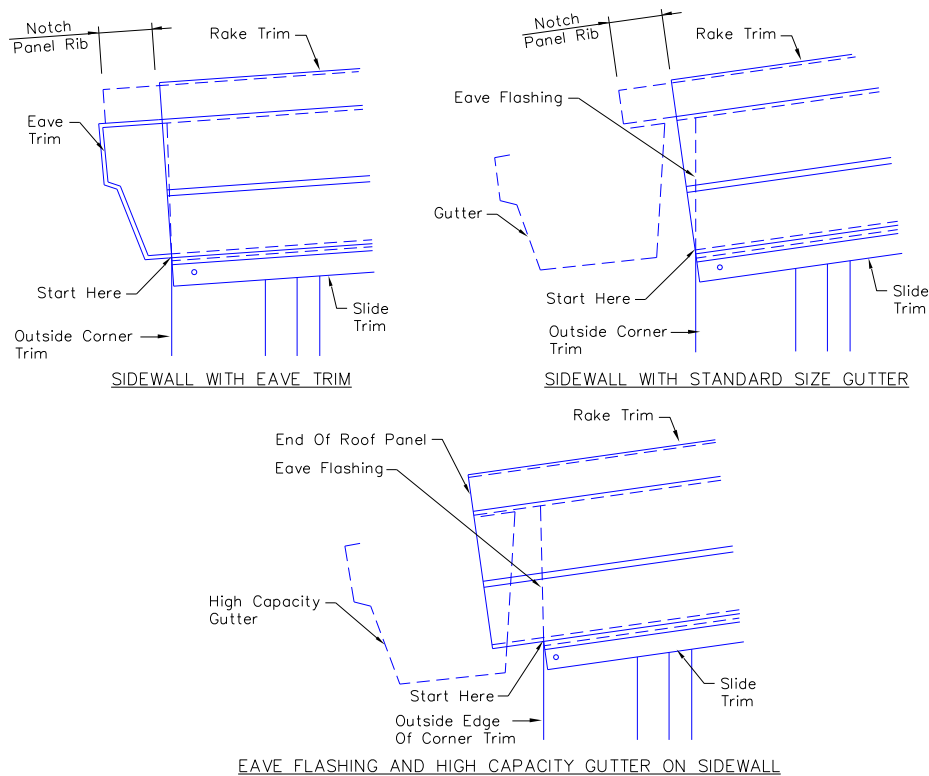

Check that the rake trim is properly aligned with the face of the wall panel. Fasten the rake trim to the roof panel/sliding rake plate with self-drilling screws at 6" centers. **BE SURE FASTENERS DO NOT PENETRATE THE ROOF PURLINS, must be clear roof members by 2"**

Check that the fasteners penetrate the center of the sealant and securely engage the panel/sliding rake plate.

ZL-16® Roof System Installation Guide

9.11.4 INSTALL SLIDE TRIM

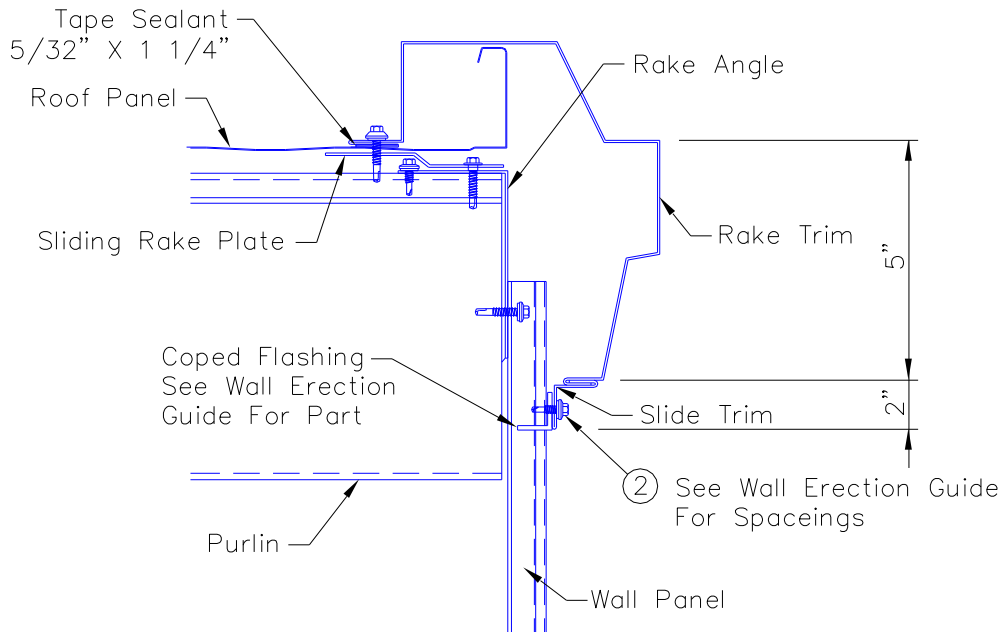

After installing rake trim to roof panel, install the slide trim starting at the edge of the outside corner trim and running continuous along the bottom edge of the rake trim as shown above.

Position the coped flashing behind the slide trim before installing ② self-drilling screws. The slide trim will allow for the roof to expand and contract.

In all cases, the bottom edge of the rake trim/slide trim must be installed straight and parallel to the roof line.

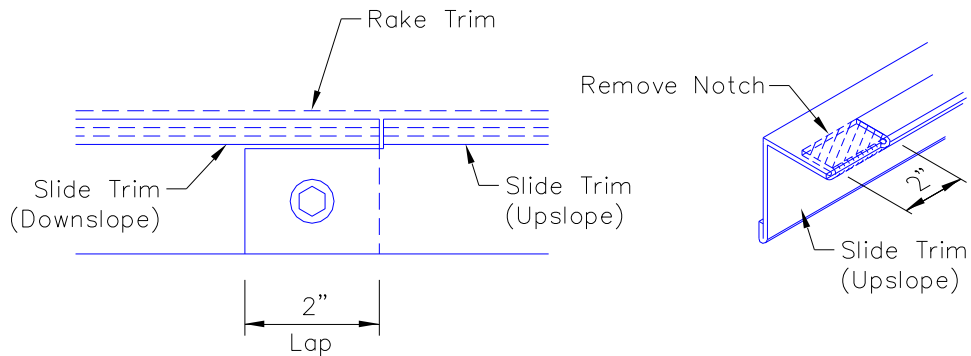

Lap ends of slide trim by field notching 2" and secure with ⑥ trim screw.

8/29/08

ZL-16® Roof System Installation Guide

9.11.5 RAKE TRIM ENDLAP

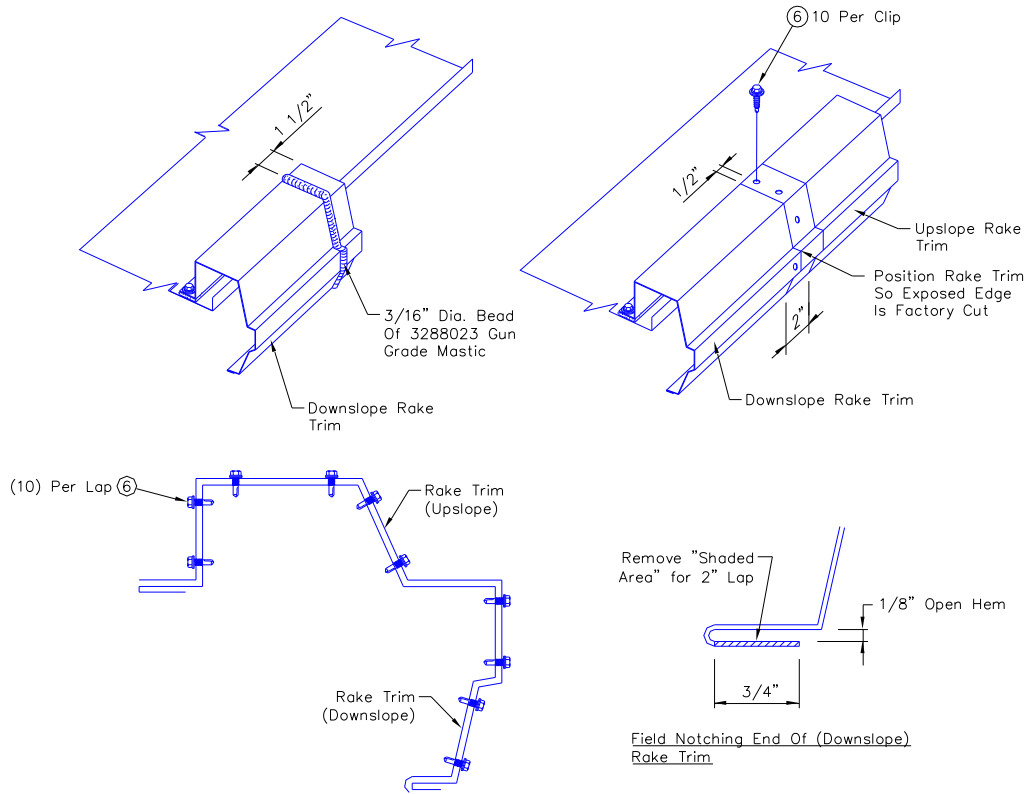

Install the rake trim from eave to ridge to provide for watershed at the splices.

Lap ends of rake trims 2" use bead of gun grade mastic and (10) (6) trim screws to secure endlap.

Field notch end of downslope rake trim for 2" lap.

9.11.6 ENDING RAKE TRIM AT RIDGE

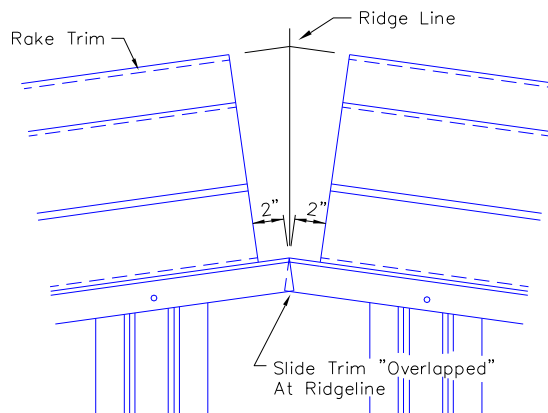

When installing rake trims on a building, trims will start "flush" with the outside edge of corner trims and stop "short" of the ridge line by 2" to allow for roof expansion.

8/29/08

ZL-16® Roof System Installation Guide

9.11.7 ENDING RAKE AT HIGH EAVE

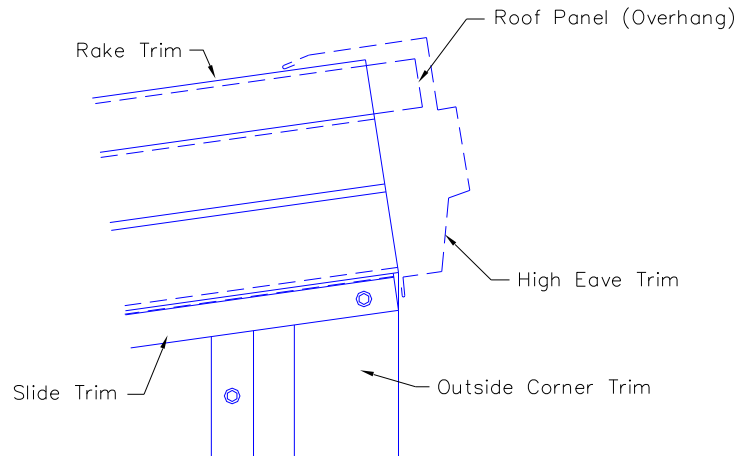

On single slope buildings, the rake trim will stop at the edge of the outside corner trim at the high eave line.

9.11.8 TERMINATION OF END DAMS AT RAKE

Once the rake trim is installed at the ridge line or high eave the end dam can be installed.

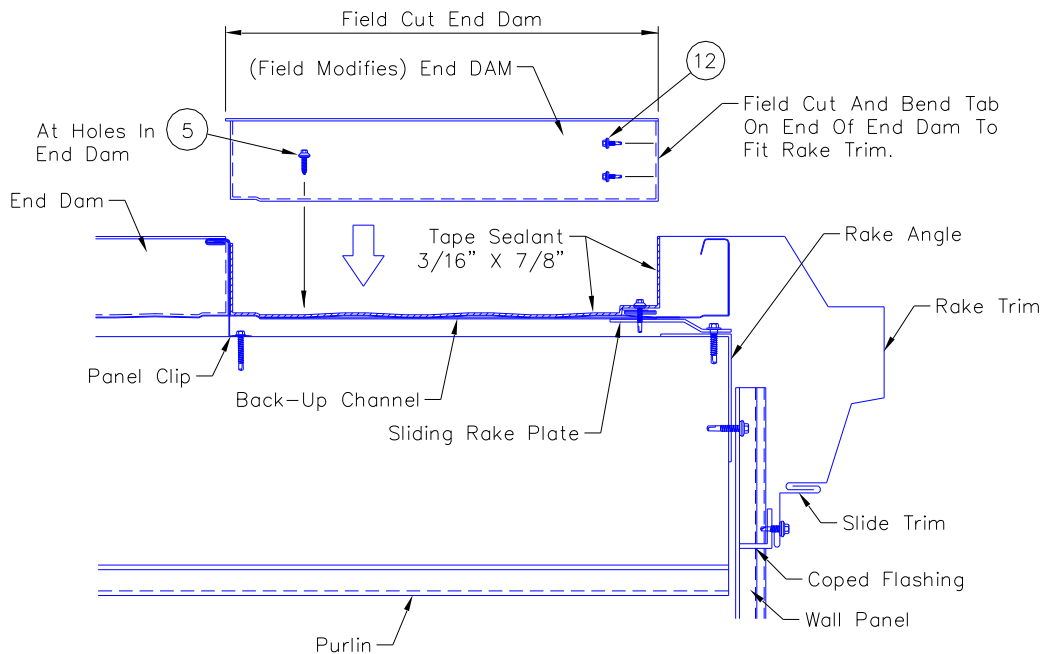

The back-up channel should end at the sliding rake plate as shown on page 84.

Install the tape sealant to extend up the face of the rake as shown.

An end dam must be field modified to fit between the roof panel rib and the rake trim.

ZL-16® Roof System Installation Guide

9.12 RIDGE CAP INSTALLATION

9.12.1 RIDGE PANEL OVERHANG VERIFICATION

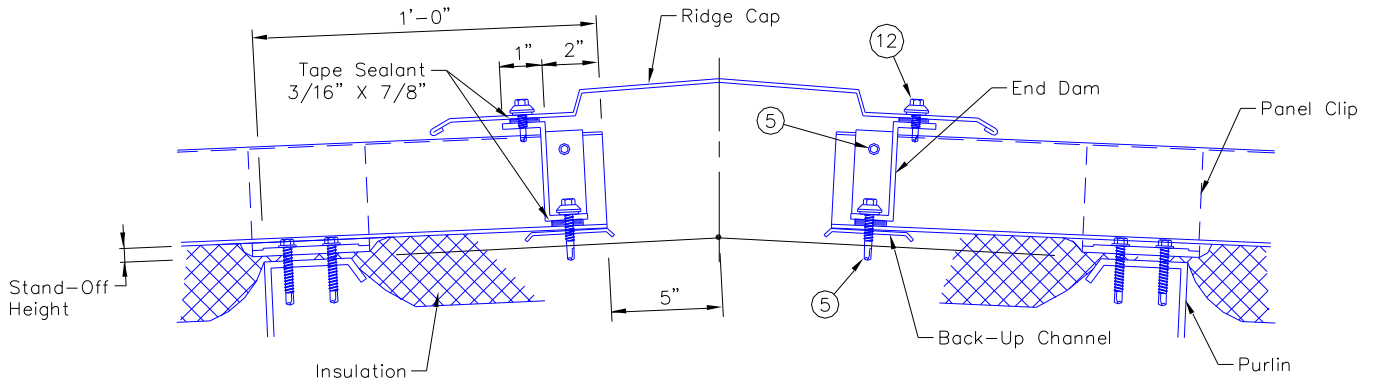

Verify that the roof panel overhang at the ridge represents the building conditions being erected.

9.12.2 STARTING AT RAKE

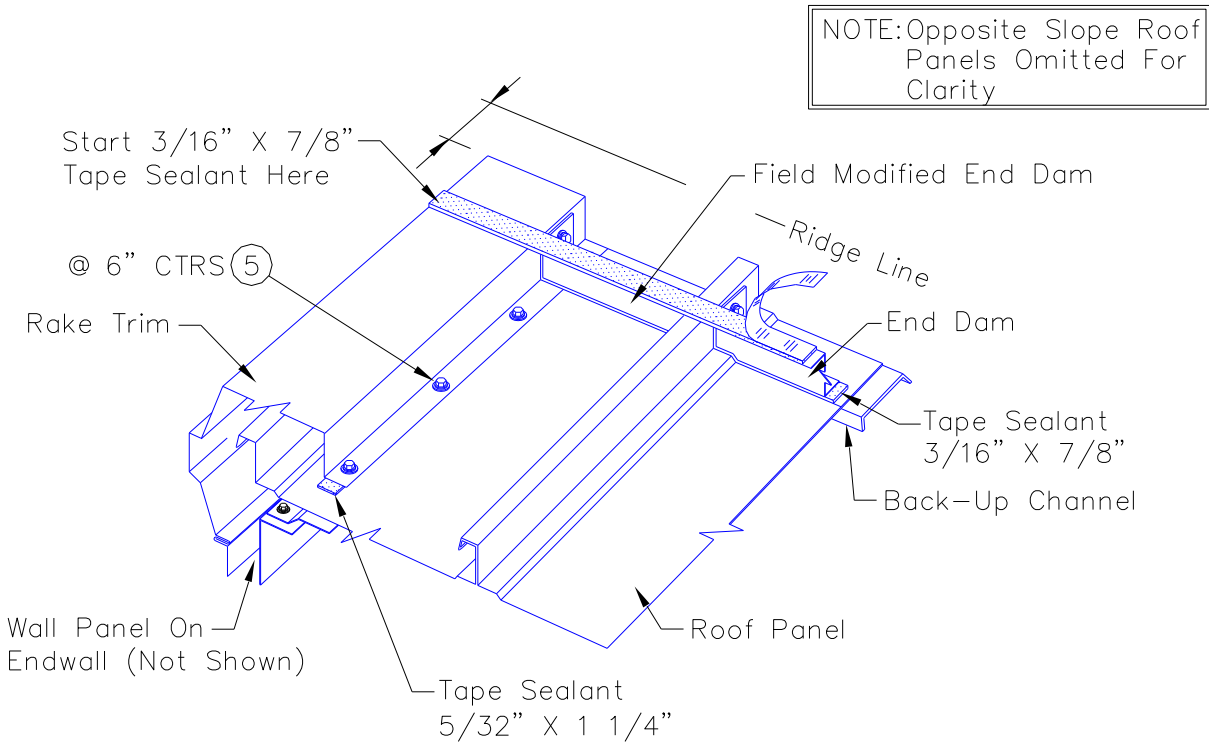

Assure rake trim is held back 2" from the centerline/ridgeline on both sides.

Apply tape sealant as shown in detail (above) on both sides of ridge.

ZL-16® Roof System Installation Guide

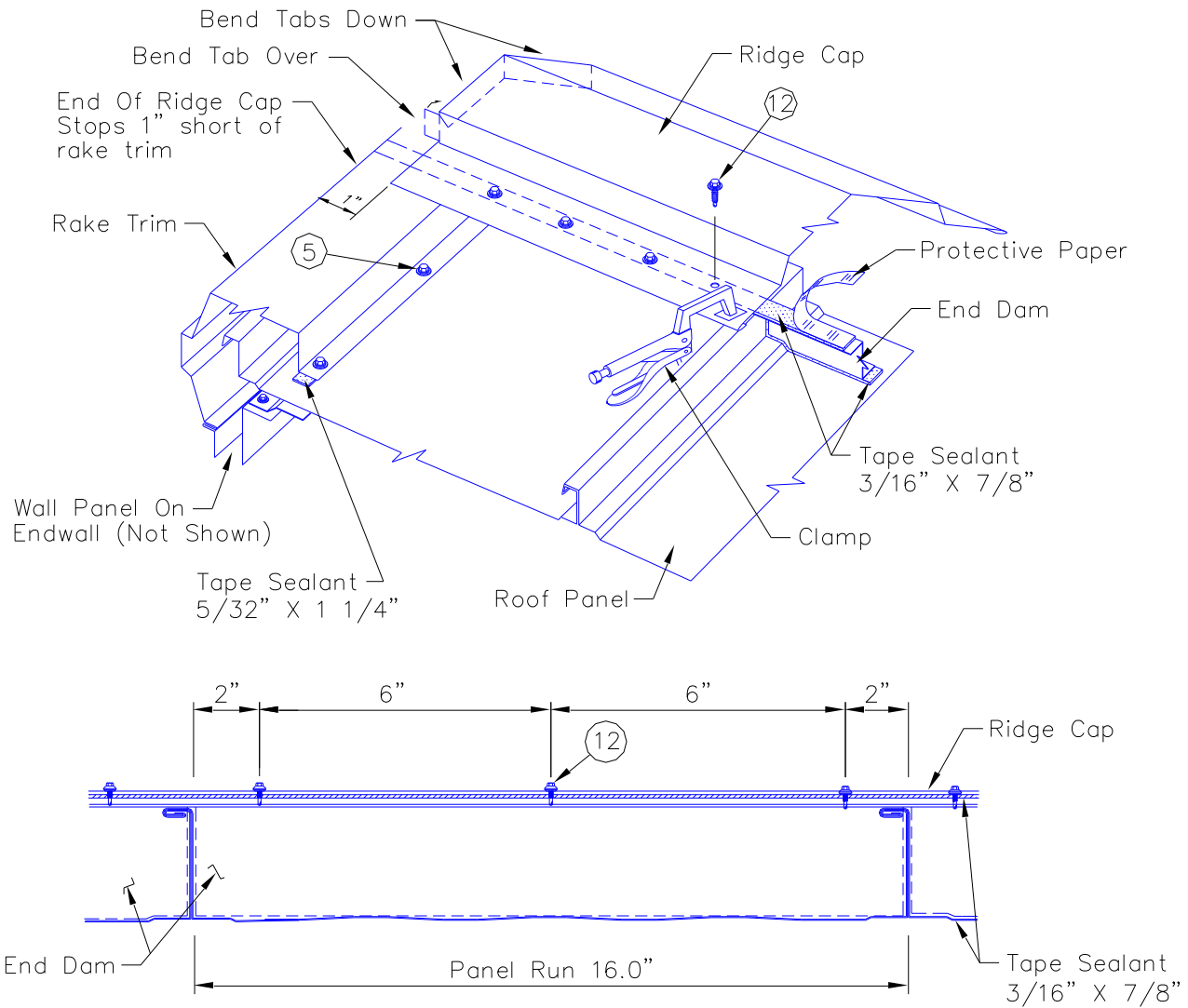

SCREW PATTERN

Install the ridge cap to span across the opposing end dams run as shown.

Bend tabs at the end of the ridge cap before attaching the membrane. Cut slits 1" long at 5 locations and field bend down tabs to form smooth edge for membrane to rest against.

Position the end of the ridge cap 1" short of the rake trim.

Align the center of the ridge cap over the ridge centerline. Use a string line to assure a straight ridge cap installation.

Fasten the ridge cap to the end dams with ⑫ self-drilling screw spaced as shown. Check that the fasteners penetrate the center of the sealant and securely engage the end dams.

IMPORTANT: To provide watershed, the ridge cap must have a positive pitch, even during roof panel contraction.

To increase the ridge cap's pitch, first fasten only one edge of the ridge cap, then push on the opposite edge of the ridge cap to deflect its center upward. Hold it in position with clamps while fastening the outer edges. Avoid making contact with the tape mastic before pushing, then set in place.

8/29/08

ZL-16® Roof System Installation Guide

9.12.3 RIDGE CAP ENDLAP

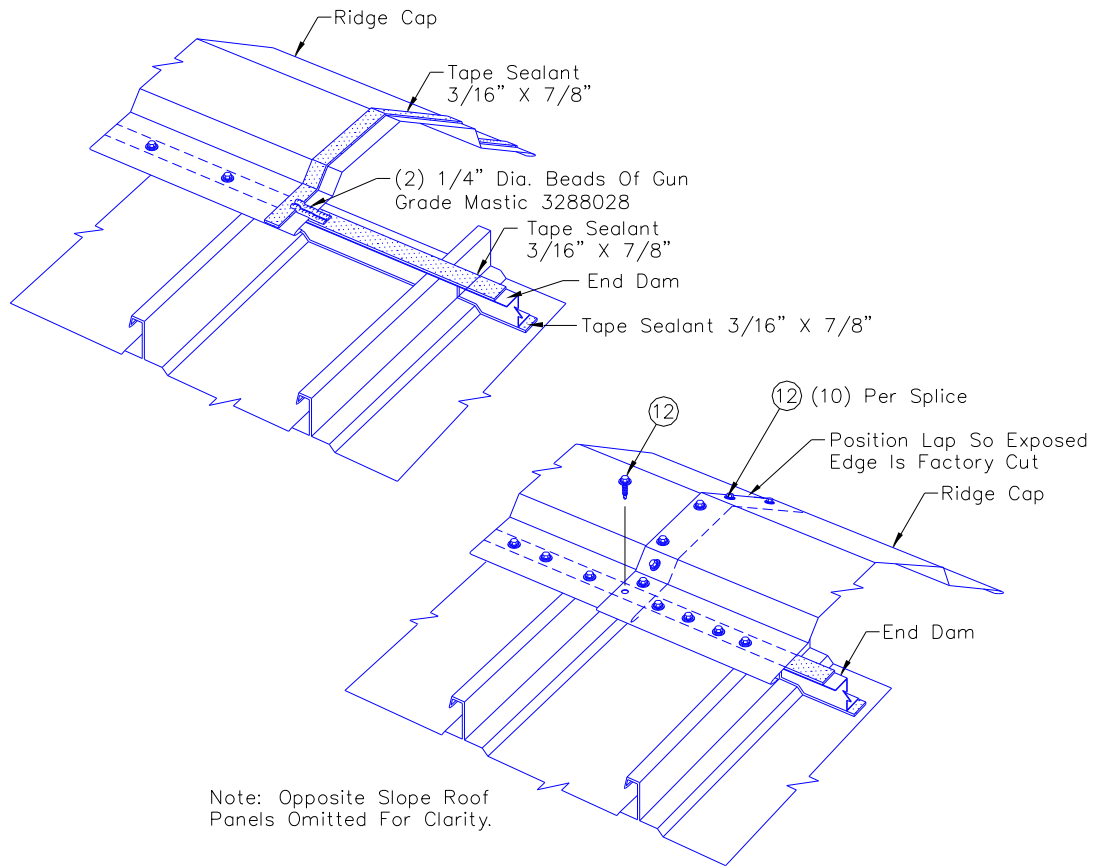

Assemble the ridge cap splices with tape sealant and ⑫ self-drilling screws as shown.

Important: The splice fasteners must be installed carefully to avoid downward deflection and buckling of the ridge cover ends

ZL-16® Roof System Installation Guide

9.13 TERMINATION OF RIDGE AT RAKE

9.13.1 INSTALLING TAPE SEALANT

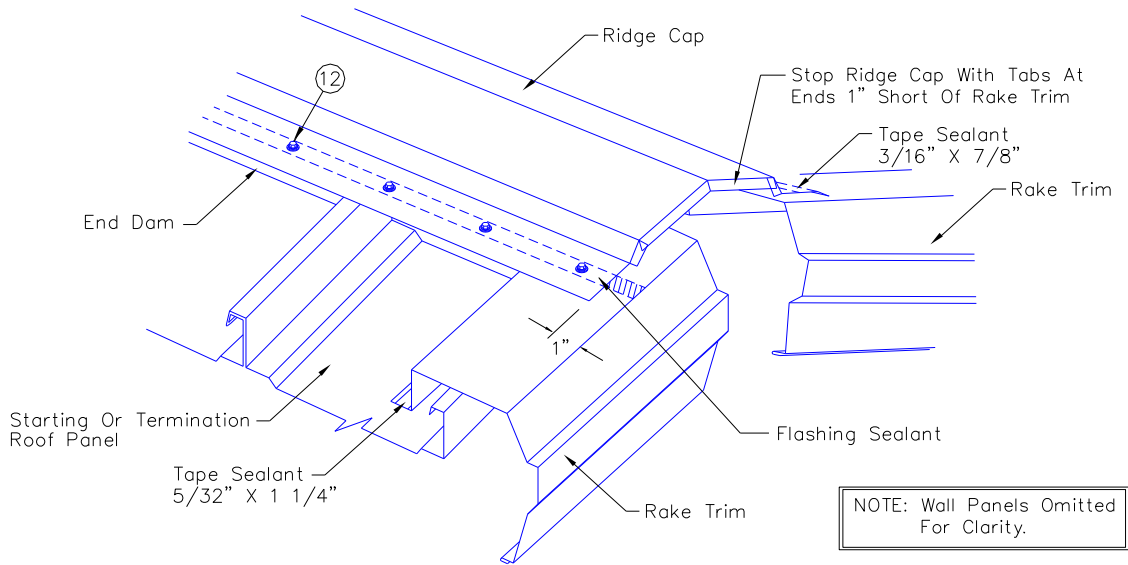

Assure that the rake trim is held back 2" from center of peak on both sides and that the 1" tabs have been bent down on the end of the ridge cap.

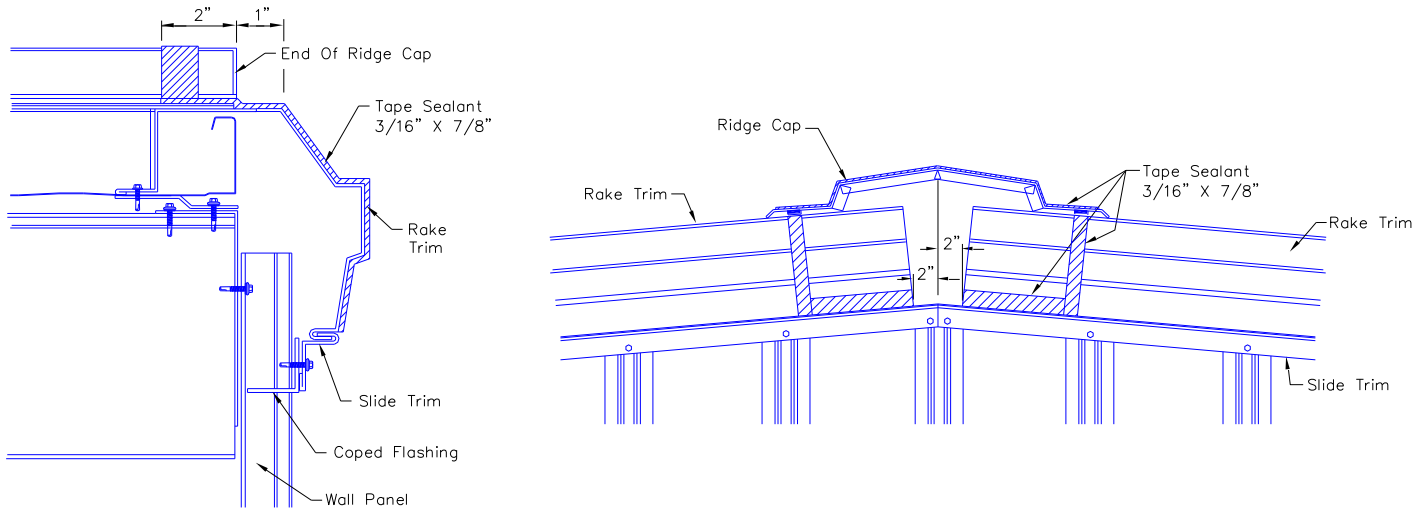

Apply tape sealant across the ridge cap, then downwards along the front face of the rake trim then along the lower edge of the trim as shown above.

ZL-16® Roof System Installation Guide

9.13.2 POSITION AND SECURE FLEXIBLE MEMBRANE

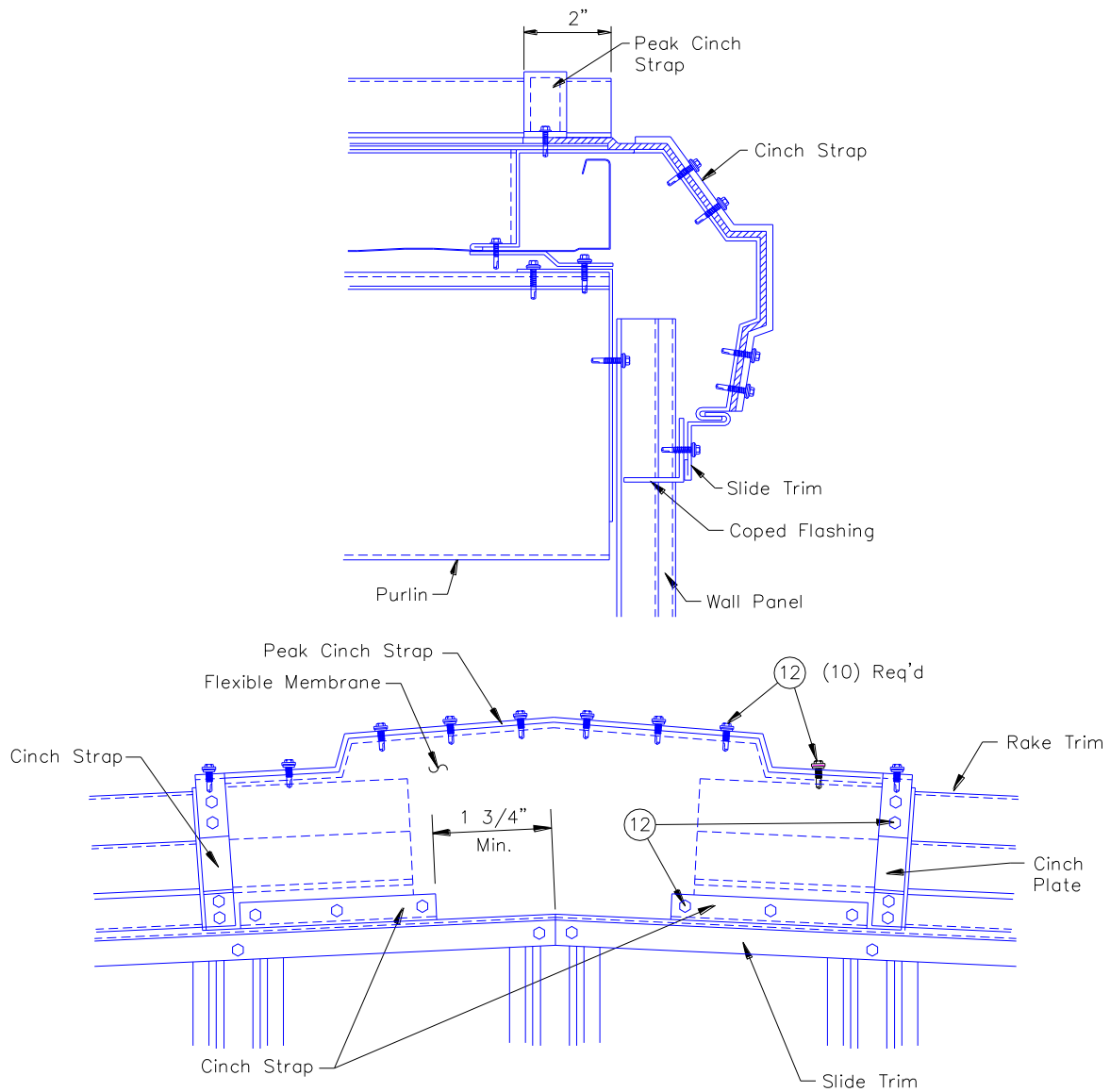

Position flexible membrane over the lines of tape sealant and secure with cinch straps. Start with a peak cinch strap across the ridge, then (2) cinch plates at the sides and then (2) cinch strap across the bottom. Use ⑫ self-drilling screws.

9.13.3 INSTALL PEAK FLASHINGS

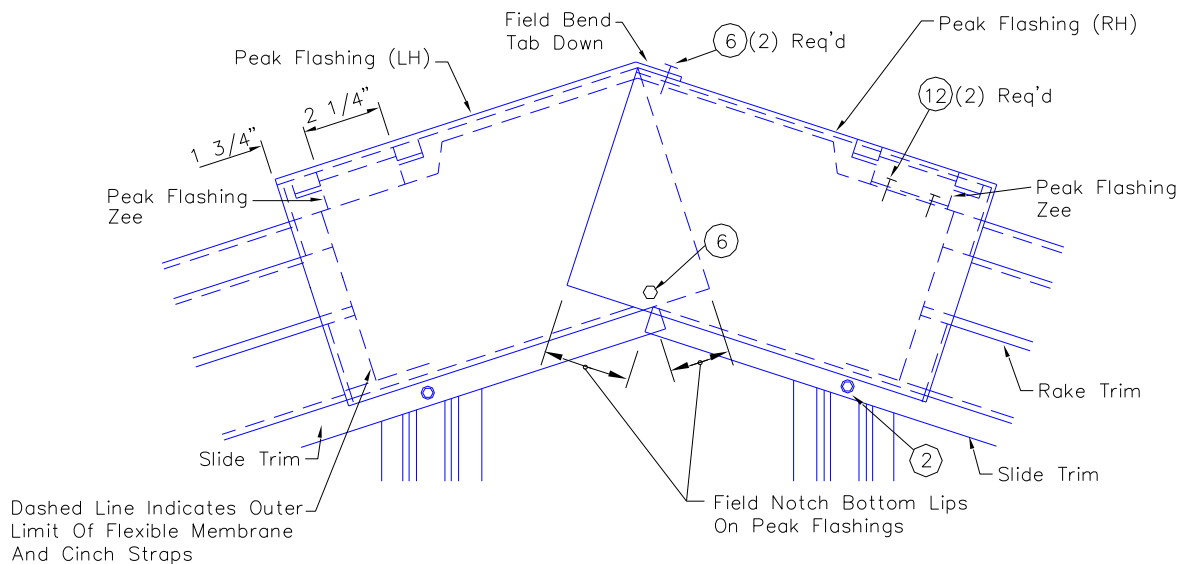
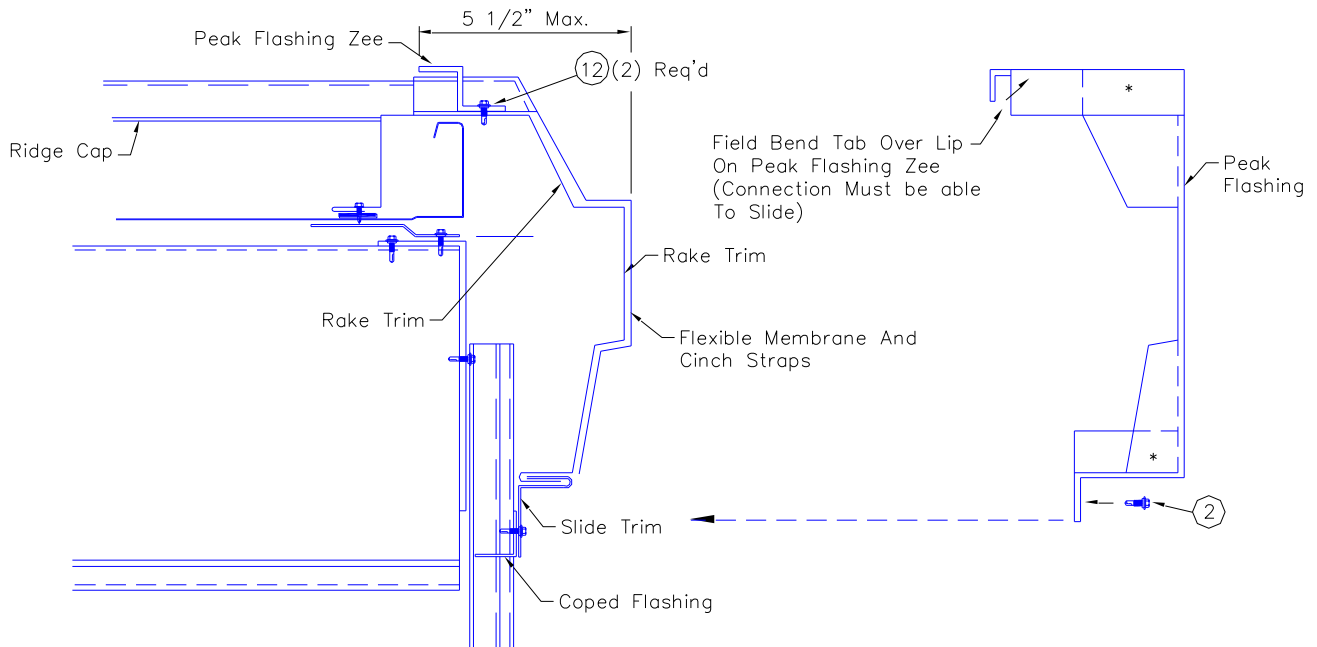

Position the (LH) and (RH) peak flashings over the flexible membrane by bending the tab along the top of the flashing over the peak flashing zeos and installing ② self-drilling screws through the bottom of the peak flashings into the slide trim.

Field notching the bottom lips on the peak flashing is required. The length is dependent on the magnitude of the roof slope.

After the peak flashings are clamped to the peak flashings and secured with screws in the front, field bend downwards the tab on the top and secure with (2) ⑥ trim screws.

8/29/08

ZL-16® Roof System Installation Guide

9.13.4 INSTALL SIGN

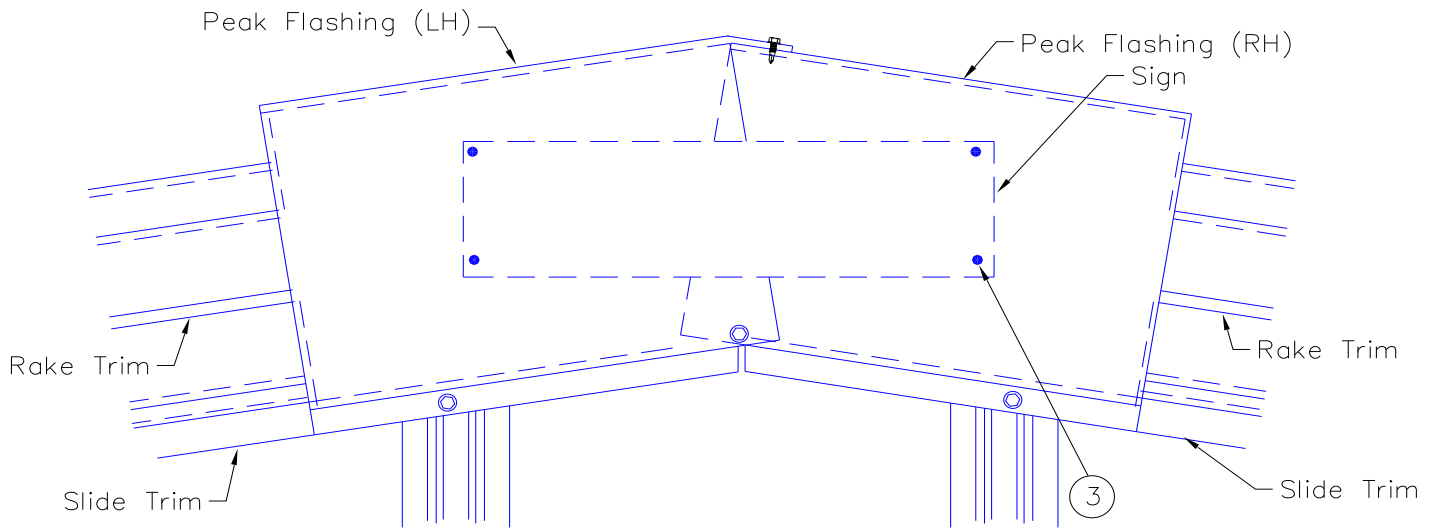

Install the sign to the peak flashing with (4) ③ screws.

ZL-16® Roof System Installation Guide

9.14 HIGH EAVE TRIM INSTALLATION

9.14.1 PANEL OVERHANG VERIFICATION

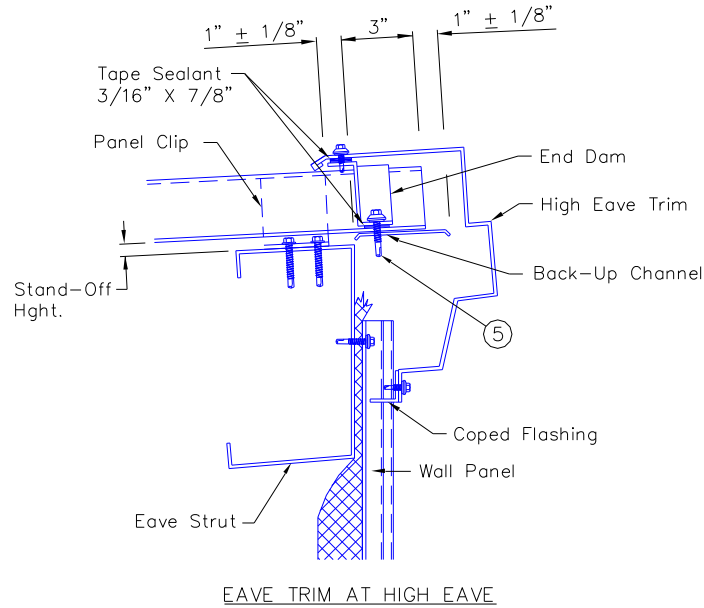

The high eave roof panel overhang dimension is critical as it will assure that the back-up channel/end dam location will be sufficient for attachment of the high eave trim and that the screws will not come in contact with the eave strut when thermal expansion and contraction of the roof surface occurs.

9.14.2 PREPARATION FOR END DAM INSTALLATION

See Section 9.8.2 for information on preparing the end of the panel for end dam installation.

9.14.3 INSTALL BACK-UP CHANNEL AND END DAMS

See section 9.8.3 for information on installation of back-up channels.

See section 9.8.4, 9.8.5 and 9.11.8 for information on installation of end dams.

9.14.4 POSITION HIGH EAVE TRIM AT CORNER

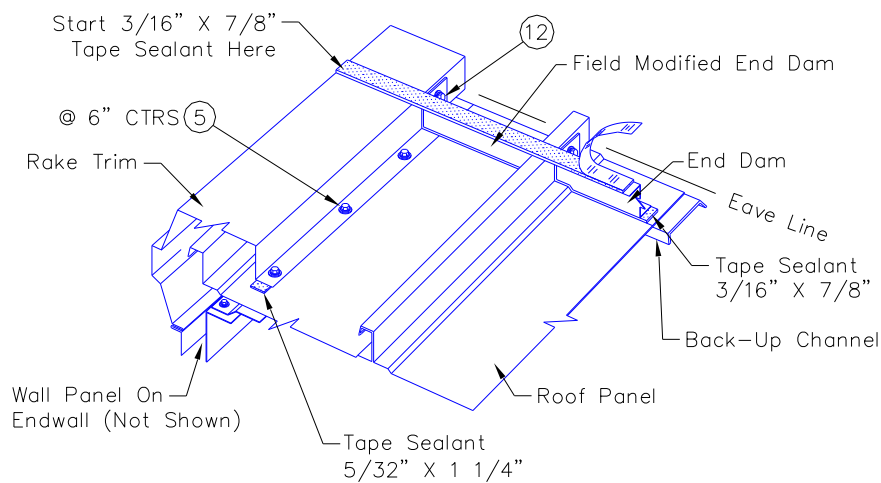

Apply tape sealant as shown (above) along end dam lips.

ZL-16® Roof System Installation Guide

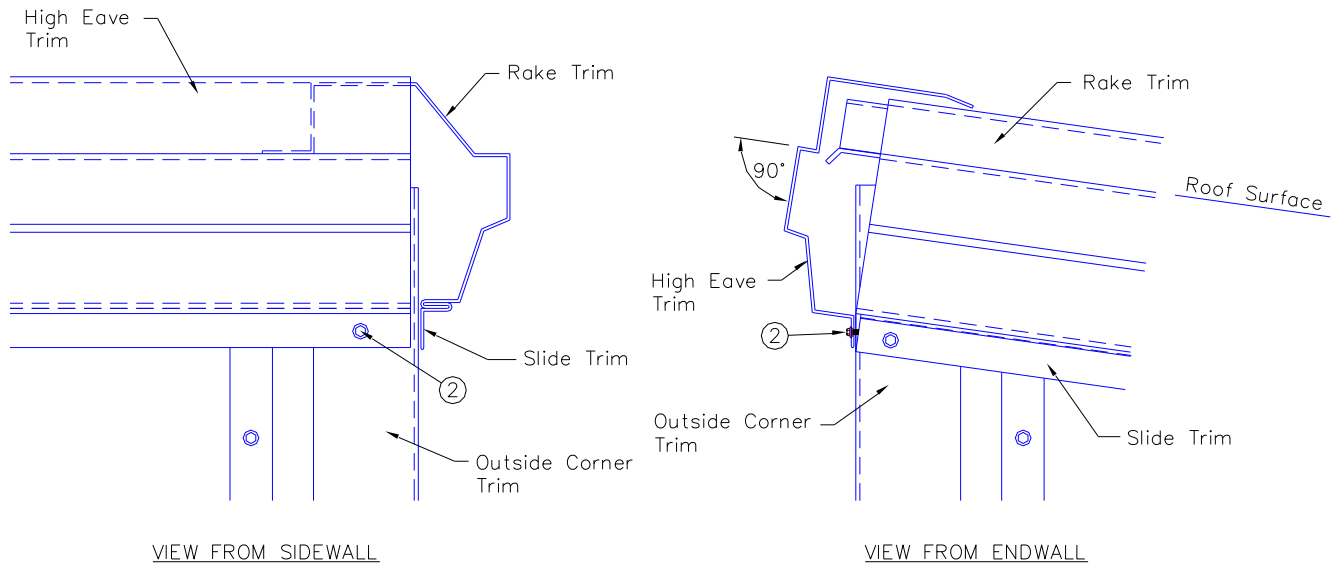

Place the top leg of the high eave trim over the tape sealant along the lips on the end dams and position the front face of the high eave trim so that it is 90 degrees to the roof surface. This will assure that the outside corner boxes will fit properly at the corners.

Position the bottom edge of the high eave flashing along the sidewall, insert the coped flashing between the trim and wall surface, then secure with ② self-drilling screws, see Wall Erection Guide for spacing.

ZL-16® Roof System Installation Guide

9.14.8 FINISHING HIGH EAVE TRIM TO RAKE AT CORNER

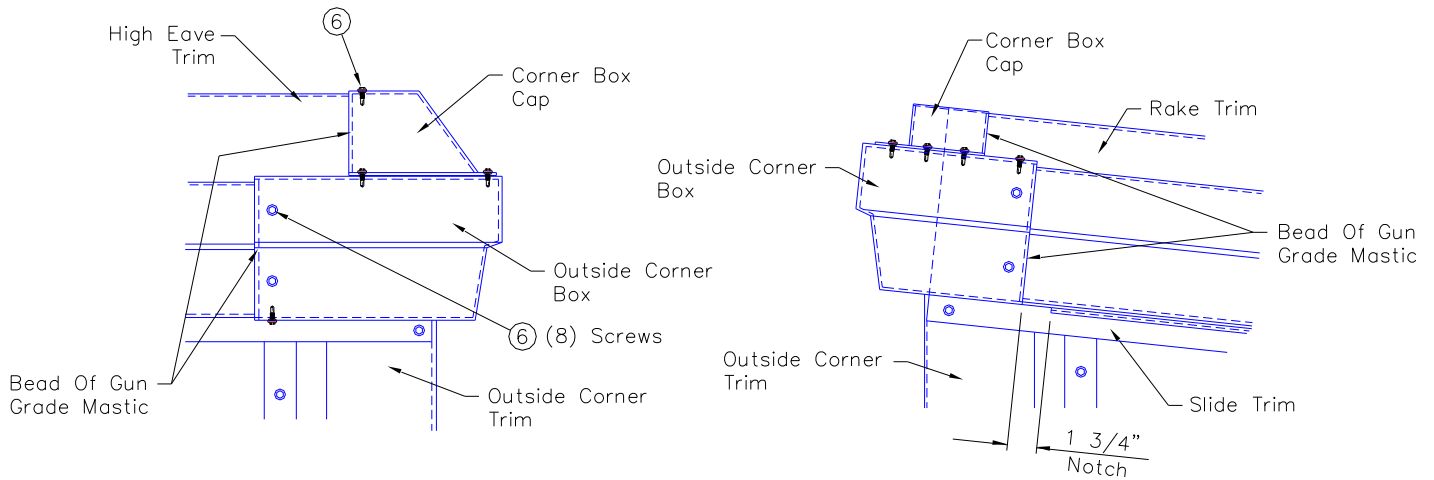

Field notch top of slide trim to allow for thermal expansion and contraction of the rake trim/outside corner box.

Field cut the top of the outside corner box to fit corner.

Install outside corner box using (8) ⑥ trim screws and gun grade mastic 3288023 along the front and top surfaces.

Install the corner box cap using (9) ⑥ screws and gun grade mastic 3288023 around the perimeter of the cap.

9.15 LOW EAVE TO RAKE, CORNER TRIMS

9.15.1 EAVE TRIM TO RAKE

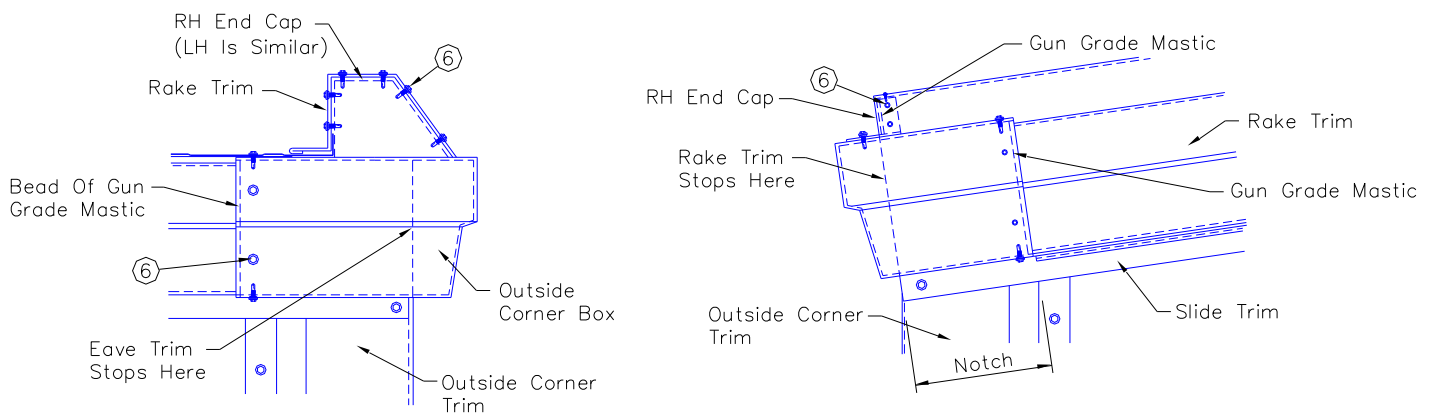

After the eave trim and rake trim are installed at the corner, the outside corner box and either the (RH) or (LH) end cap will be used to finish the corner.

Field notch or remove any portion of the roof panel and extends beyond the end of the rake trim. Field notch the slide trim to clear the bottom lip of the outside corner box.

Field cut the top of the outside corner box to fit corner.

Install outside corner box using (8) ⑥ trim screws and gun grade mastic 3288023 along the front and top surfaces.

Install the (RH) or when applicable (LH) end cap with (9) ⑥ trim screws and gun grade mastic 3288023 around the perimeter of the end cap.

8/29/08

ZL-16® Roof System Installation Guide

9.15.2 EAVE FLASHING TO RAKE

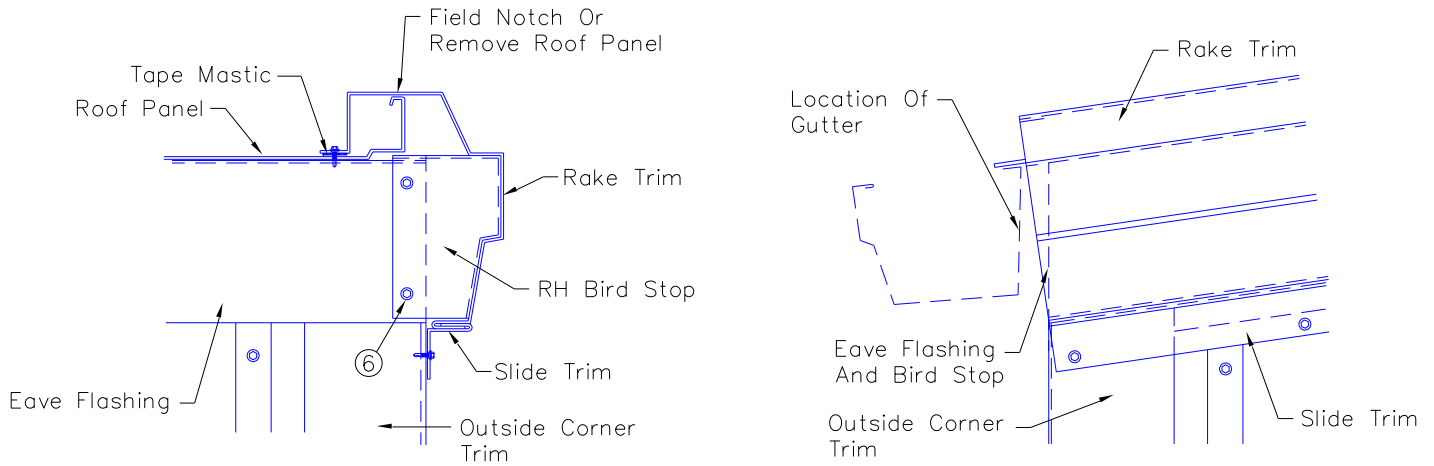

Where the eave flashing stops at the edge of the outside corner trim (RH) or when applicable (LH) bird stop will be used to flash to the back side of the rake trim.

Attach the bird stop with (2) ⑥ trim screws.

The end cap and outside corner box used at this eave to rake intersection will be installed when the gutter is in position, which is described elsewhere in this guide.

9.16 STANDARD AND HIGH CAPACITY GUTTER INSTALLATION

9.16.1 PANEL OVERHANG VERIFICATION

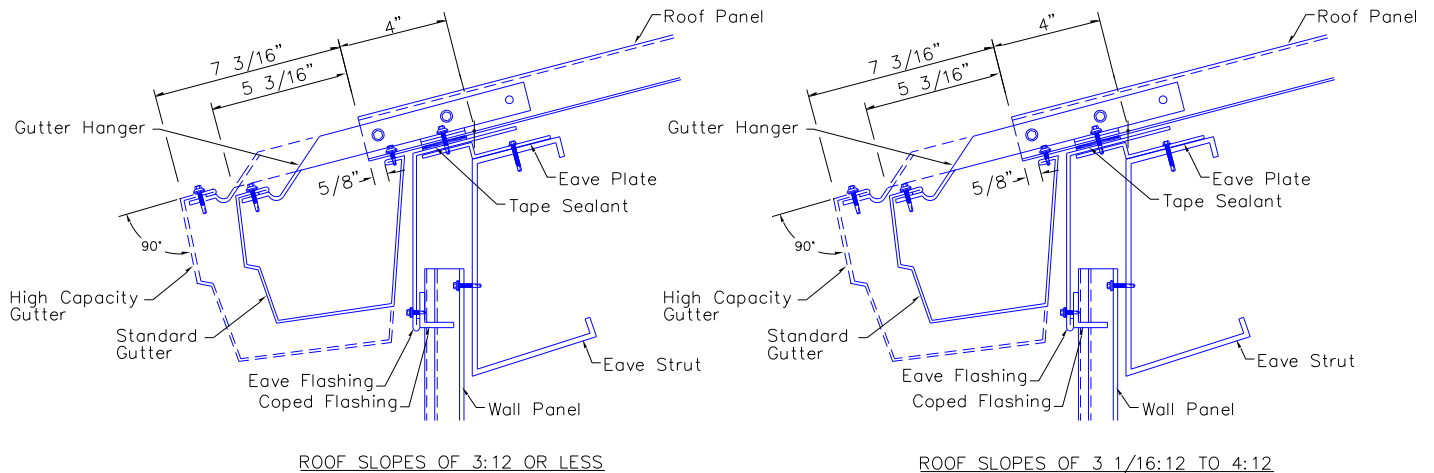

Verify that the roof panel overhang at the eave is 4". This dimension will assure that the back lip on the gutter can be attached to the roof panel at (3) three locations, that are 1" in from the end of the panel.

ZL-16® Roof System Installation Guide

9.16.2 INSTALL GUTTER END CAP

The location of the end cap from the end of the gutter is dependent on whether STANDARD or HIGH CAPACITY gutters are used.

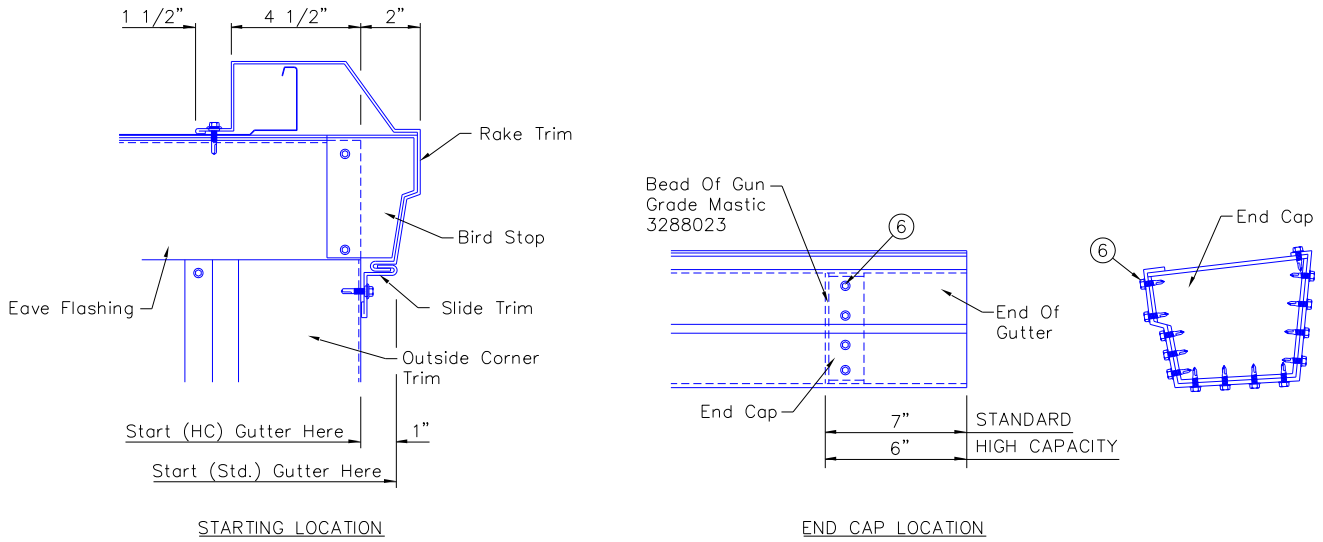

Assemble the gutter end cap using gun grade mastic 3288023 and (14) ⑥ trim screws.

9.16.3 POSITIONING FIRST GUTTER SECTION

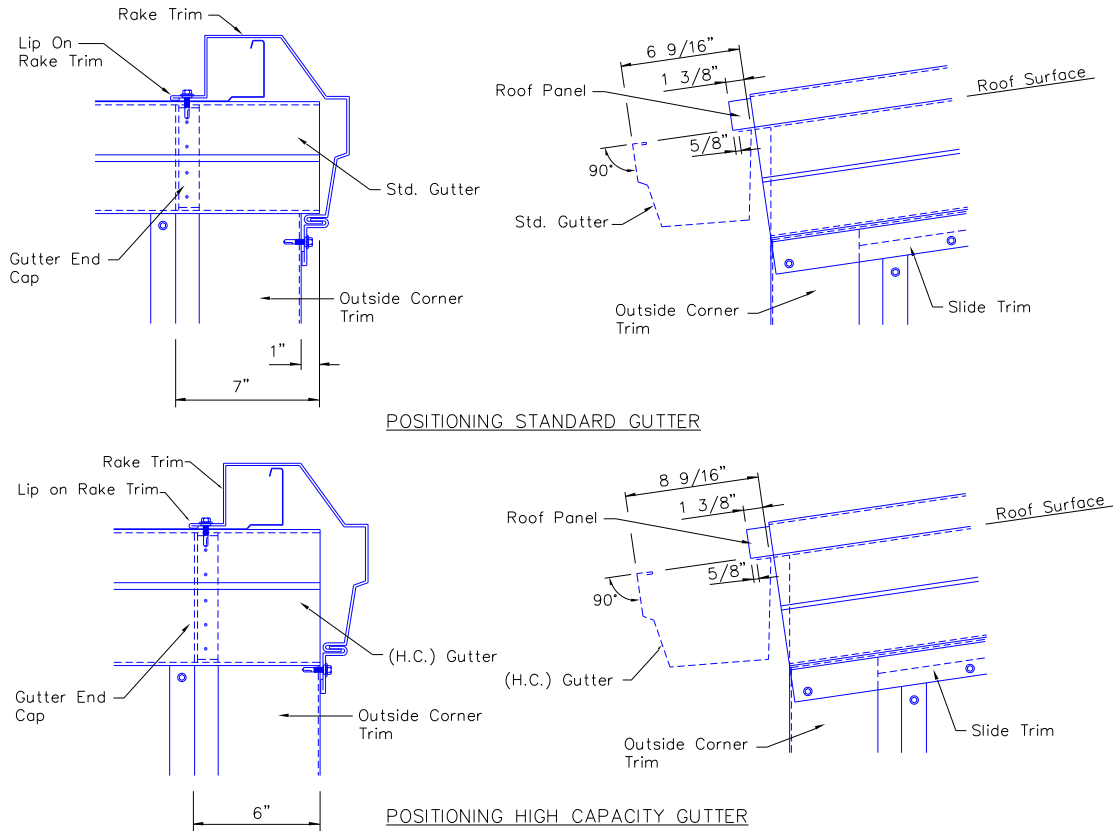

Lift the first gutter section into position as shown above and temporarily clamp the back flange of the gutter to the roof panel.

The start and finish ends of the gutter will be as shown above with the gutter end cap in line with lip on rake trim.

8/29/08

ZL-16® Roof System Installation Guide

9.16.4 INSTALLING GUTTER HANGERS

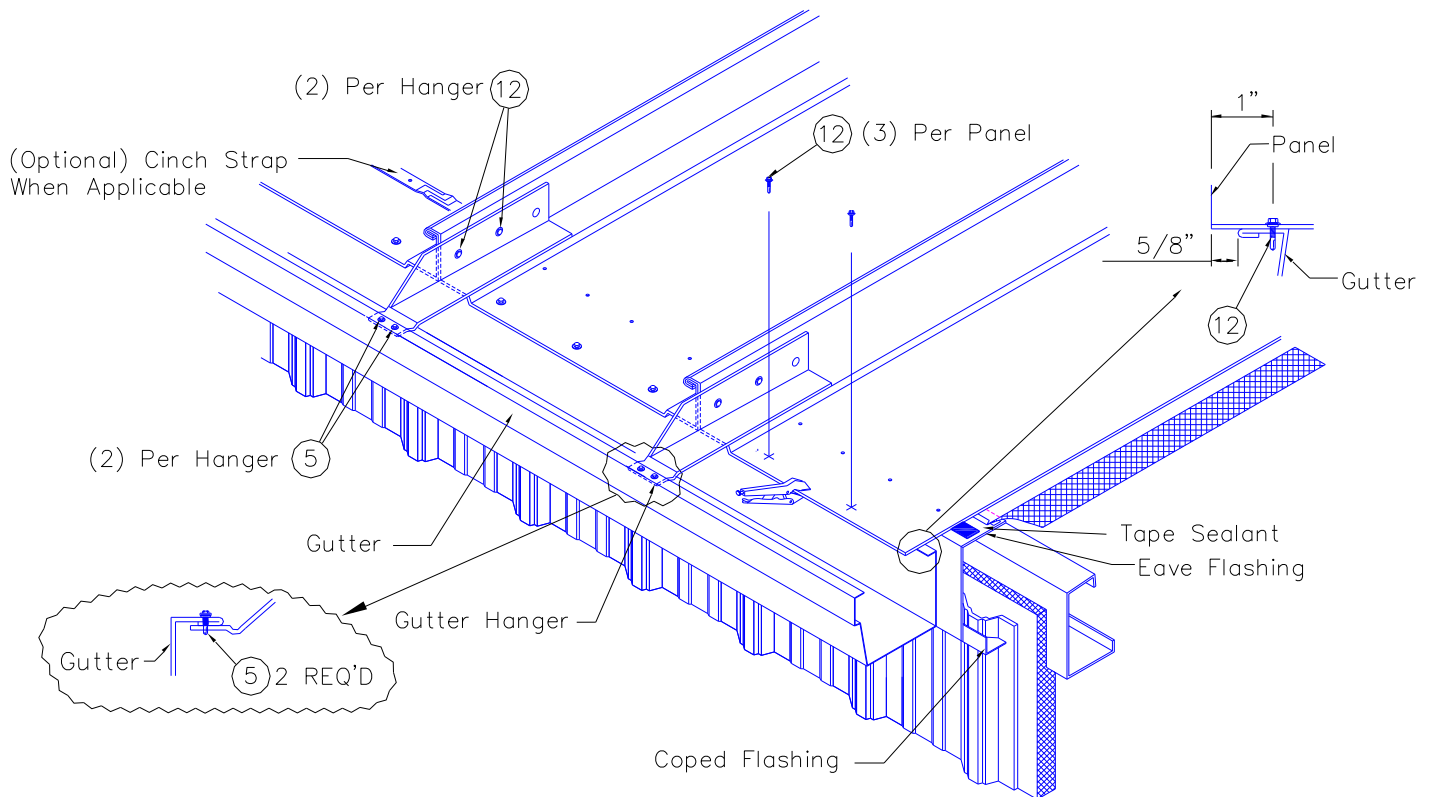

After lifting gutter section into position under the edge of the roof panels and temporarily clamping the back flange of the gutter to the roof panel fasten the gutter to the roof panel with ⑫ self-drilling screws at (3) locations per panel.

Align the outer edge of the gutter straight and level. Use a string line to assure that the gutter is straight.

Apply 1" long piece of flashing sealant on backside of gutter hanger at two screw locations before placing gutter hanger into position. When installing hangers, position so as to keep the front face of the gutter 90 degree to the roof surface, thus assuring that the outside corner boxes fit properly at the corners.

For installation of standard gutter use applicable spacing from either Table A or Table B (below). For high capacity gutter space ALL gutter hangers at 2'-8" spacing.

TABLE A (Buildings Ordered Using Roof Live Load)	
ROOF LIVE LOAD	STRAP SPACING
Less Than 40# L.L.	4'-0"
40# L.L. And Greater	2'-8"

TABLE B (Buildings Ordered Using Ground Snow Load)	
GROUND LIVE LOAD	STRAP SPACING
Less Than 60 PSF	4'-0"
40# L.L. And Greater	2'-8"

Fasten gutter hanger with (2) ⑫ self-drilling screws to roof panel.
Position the end of the gutter hanger under the outer lip of the gutter and secure with (2) self-drilling screws.

ZL-16® Roof System Installation Guide

9.16.5 SPLICING GUTTER

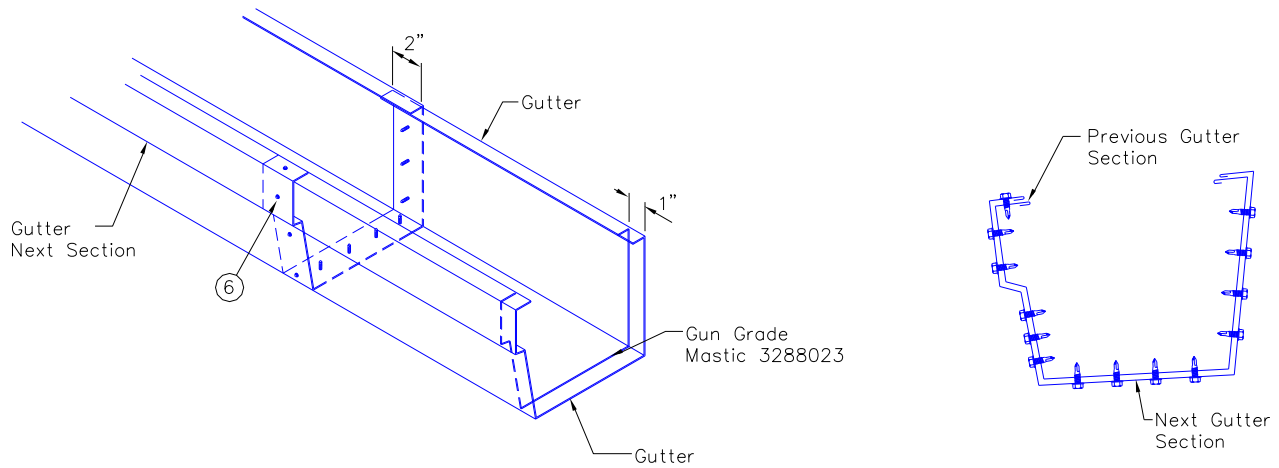

Lap all remaining gutter sections by 2" onto previous gutter. Each lap will include bead of gun grade mastic 3288023 and (14) ⑥ trim screws.

9.16.6 INSTALLING GUTTER EXPANSION JOINT

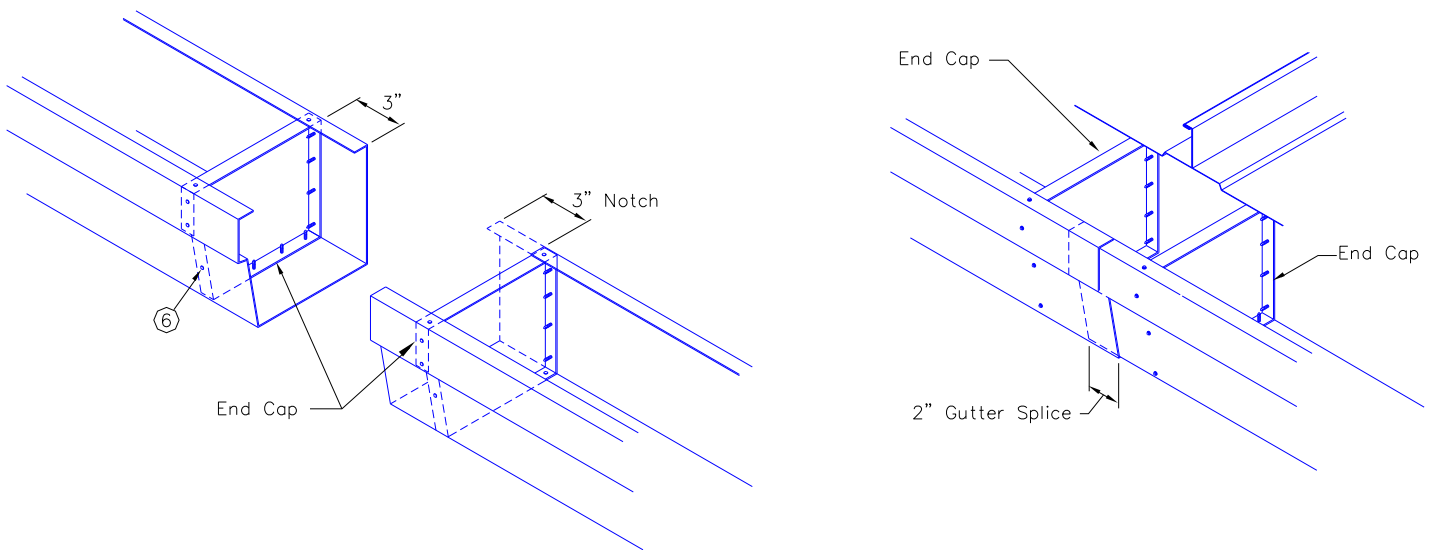

When a run of gutter exceeds 130 feet an expansion joint will be used. The number of joints and their locations along the run are shown in the table below.

TABLE EXPANSION JOINT LOCATIONS	
Length of run	Location
130'-1" to 260'-0"	Approx. mid point
260'-1" to 390'-0"	Approx. 1/3 points
390'-1" to 520'-0"	Approx. 1/4 points

ZL-16® Roof System Installation Guide

9.16.7 FINISHING STANDARD GUTTER TO RAKE AT CORNER

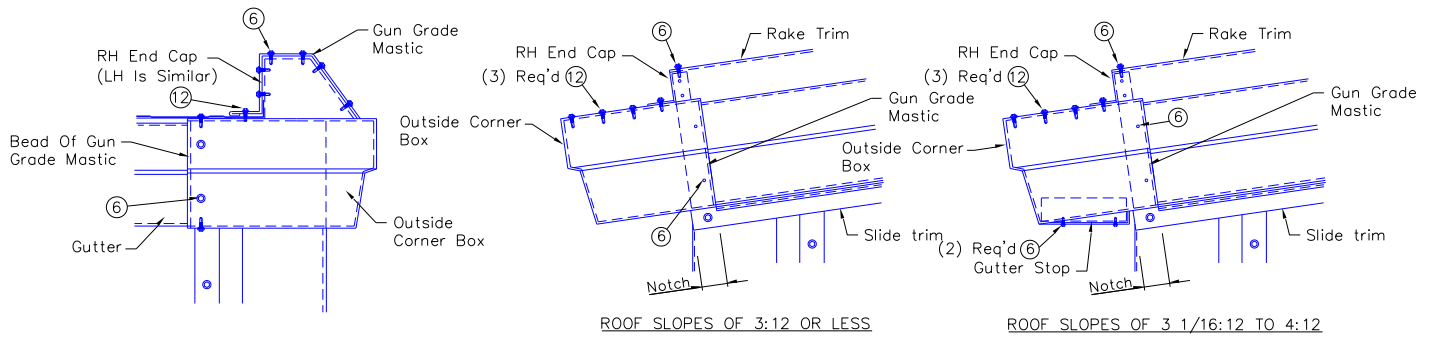

After the gutter and rake trim are installed at the corner, the outside corner box and either the (RH) or (LH) End cap will be used to finish the corner. Prior to installing outside corner box, when required install the gutter stop using (2) ⑥ trim screws.

Field notch the slide trim to clear the bottom lip of the outside corner box.

Field cut the top of the outside corner box to fit corner.

Install outside corner box using (8) ⑥ trim screws and gun grade mastic 3288023 along the front and top surfaces.

Place (3) ⑫ self-drilling screws through top of outside corner box and top lip of gutter end cap.

Install the (RH) or when applicable (LH) end cap with (9) ⑥ trim screws and gun grade mastic 3288023 around the perimeter of the end cap.

9.16.8 FINISHING HIGH CAPACITY GUTTER TO RAKE AT CORNER

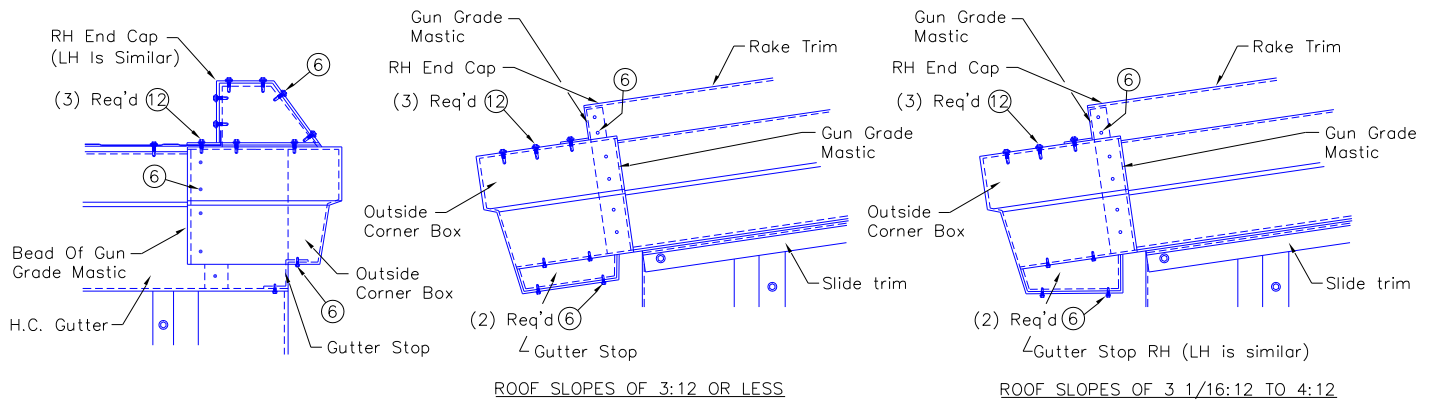

Before installing outside corner box, install the gutter stop using (2) ⑥ trim screws.

Field cut the top and front of the outside corner box to fit the corner.

Install outside corner box using (8) ⑥ trim screws and gun grade mastic 3288023 along the front and top surfaces.

Place (3) ⑫ self-drilling screws through top of outside corner box and top lip of gutter end cap.

Install the (RH) or when applicable (LH) end cap with (9) ⑥ trim screws and gun grade mastic 3288023 around the perimeter of the end cap.

8/29/08

ZL-16® Roof System Installation Guide

9.17 RIB CONCEALING AND HIGH CAPACITY GUTTER INSTALLATION

9.17.1 PANEL OVERHANG VERIFICATION

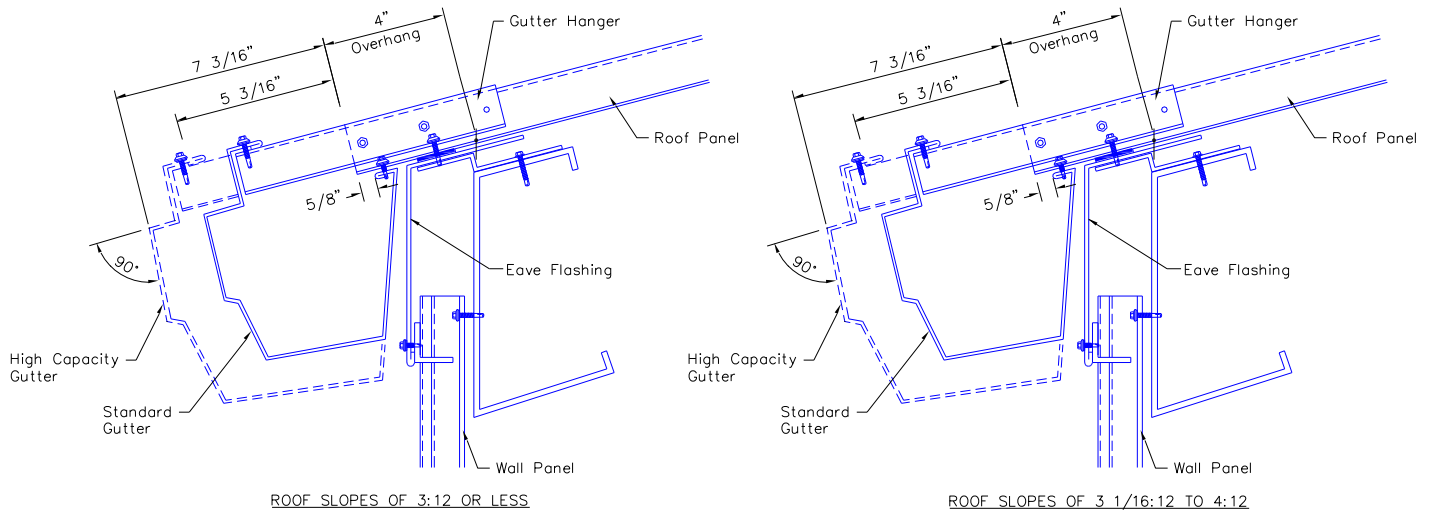

Verify that the roof panel overhang at the eave is 4". This dimension will assure that the back lip on the gutter can be attached to the roof panel at (3) three locations, that are 1" in from the end of the panel.

9.17.2 INSTALL GUTTER END CAP

The location of the end cap from the end of the gutter is dependent on whether RIB CONCEALING or HIGH CAPACITY gutters are used.

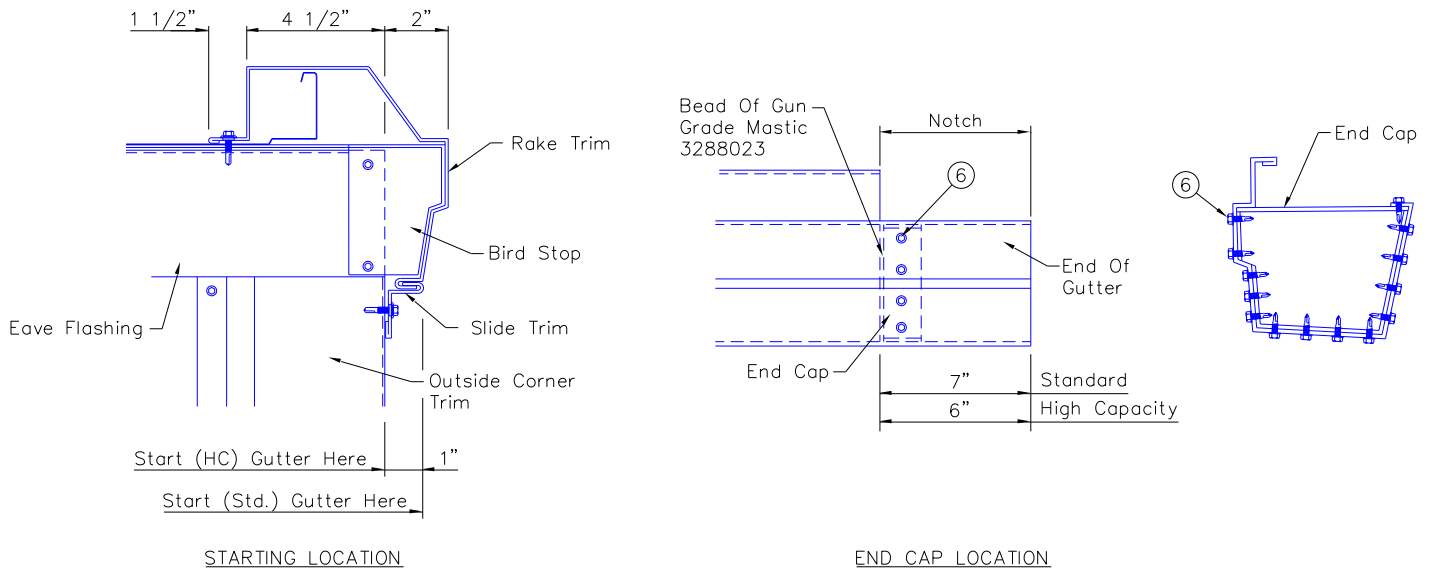

Assemble the gutter end cap using gun grade mastic 3288023 and (14) ⑥ trim screws.

9.17.3 POSITIONING FIRST GUTTER SECTION

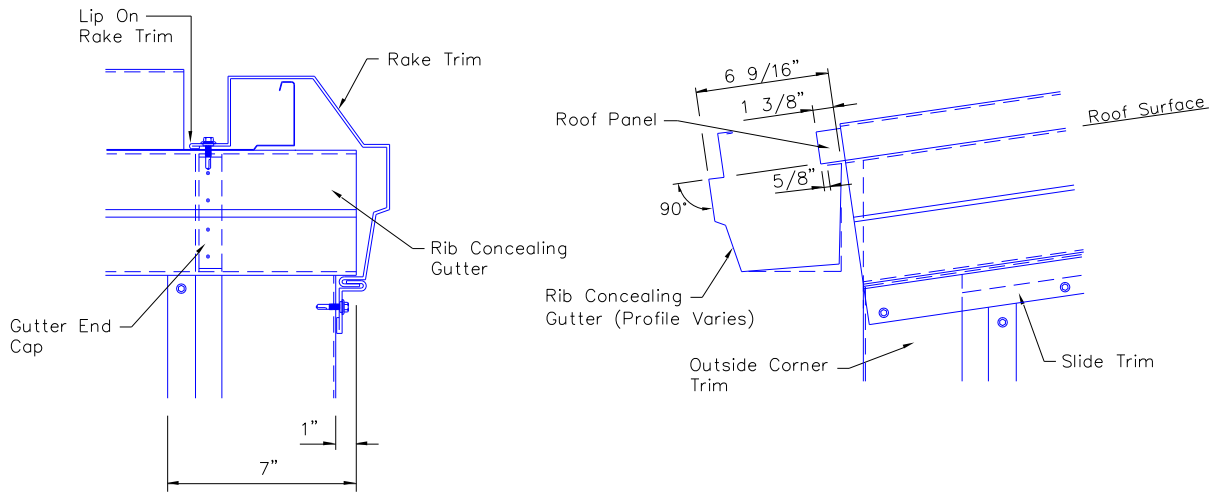

POSITIONING RIB CONCEALING GUTTER

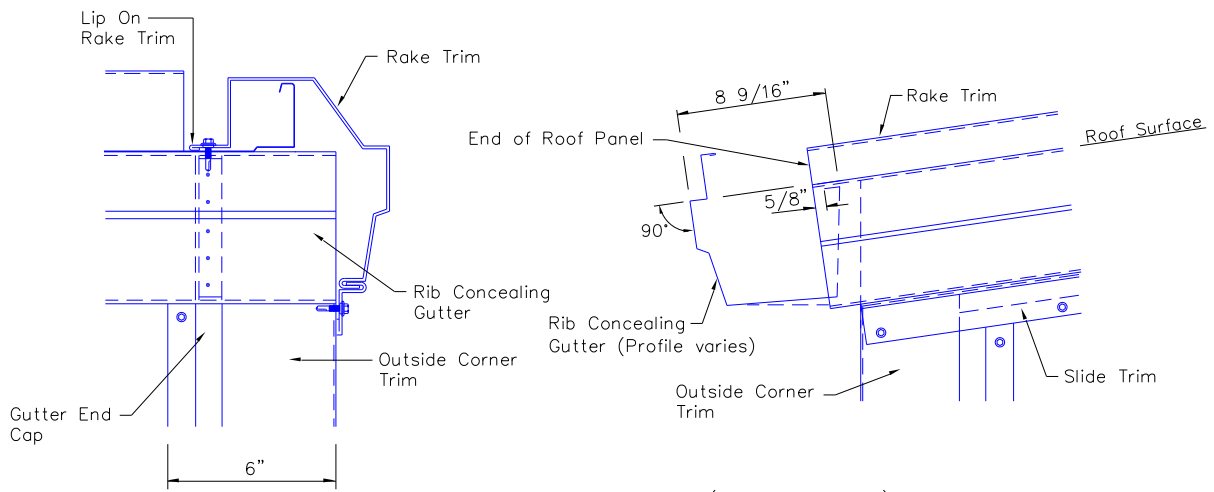

POSITIONING RIB CONCEALING (HIGH CAPACITY) GUTTER

Lift the first gutter section into position as shown above and temporarily clamp the back flange of the gutter to the roof panel.

The start and finish ends of the gutter will be as shown above with the gutter end cap in line with lip on rake trim.

9.17.4 INSTALLING GUTTER HANGERS

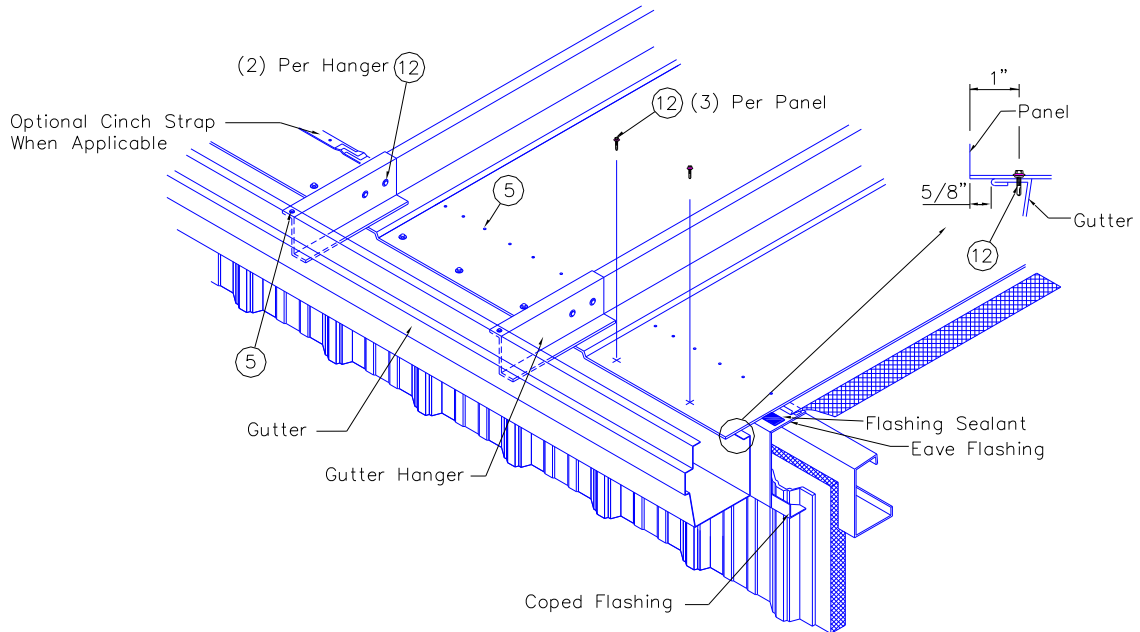

After lifting gutter section into position under the edge of the roof panels and temporarily clamping the back flange of the gutter to the roof panel, fasten the gutter to the roof panel with (3) (12) self-drilling screws at (3) locations per panel.

Align the outer edge of the gutter straight and level. Use a string line to assure that the gutter is straight.

Apply 1" long piece of flashing sealant on backside of gutter hanger at two screw locations before placing gutter hanger into position. When installing hangers, position so as to keep the front face of the gutter 90 degrees to the roof surface, thus assuring that the outside corner boxes fit properly at the corners.

Install gutter hanger at 2'-8" spacing.

Fasten gutter hanger with (2) (12) self-drilling screws through the roof panel and (1) self-drilling screw through gutter lip.

9.17.5 SPLICING GUTTER

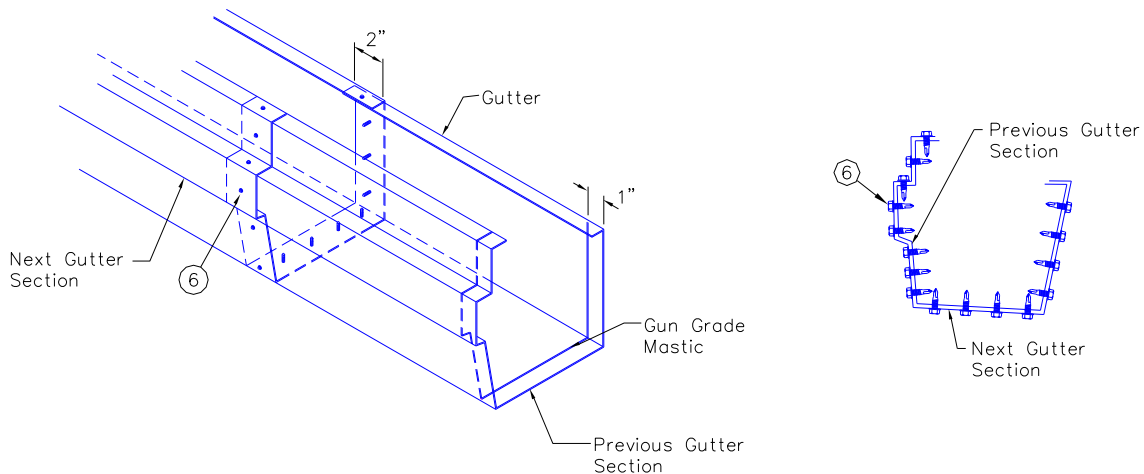

Lap all remaining gutter sections by 2" onto previous gutter. Each lap will include bead of gun grade mastic 3288023 and (16) (6) trim screws.

ZL-16® Roof System Installation Guide

9.17.6 INSTALLING GUTTER EXPANSION JOINT

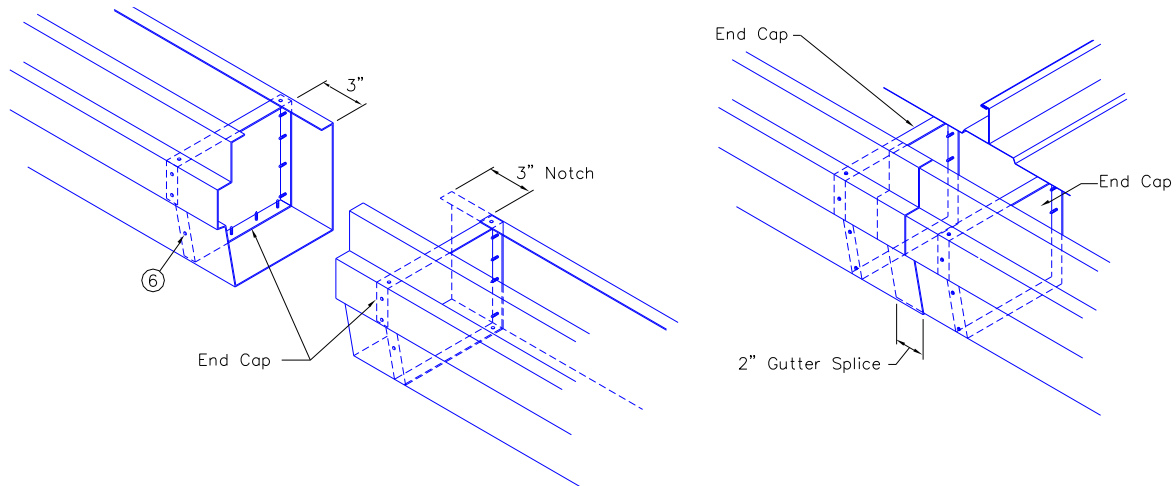

When a run of gutter exceeds 130 feet an expansion joint will be used. The number of joints and their locations along the run are shown in the table shown.

TABLE EXPANSION JOINT LOCATIONS	
Length of run	Location
130'-1" to 260'-0"	Approx. mid point
260'-1" to 390'-0"	Approx. 1/3 points
390'-1" to 520'-0"	Approx. 1/4 points

9.17.7 INSTALL OUTSIDE CORNER BOX AND END CAP TO RIB CONCEALING GUTTER

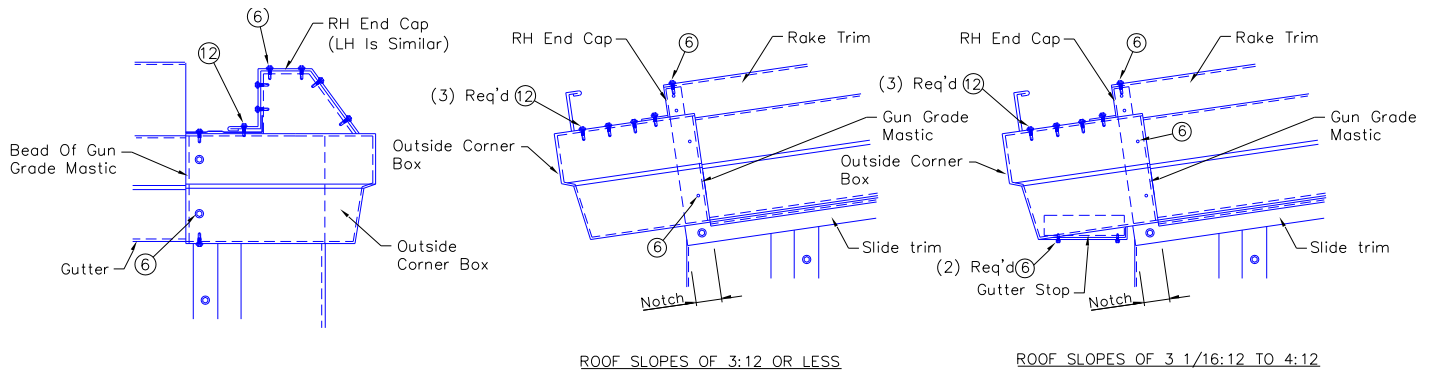

After the gutter and rake trim are installed at the corner, the outside corner box and either the (RH) or (LH) End cap will be used to finish the corner. Prior to installing outside corner box, when required install the gutter stop using (2) (6) trim screws.

Field notch the slide trim to clear the bottom lip of the outside corner box.

Field cut the top of the outside corner box to fit corner.

Install outside corner box using (8) (6) trim screws and gun grade mastic 3288023 along the front and top surfaces.

Place (3) (6) self-drilling screws through top of outside corner box and top lip of gutter end cap.

Install the (RH) or when applicable (LH) end cap with (9) (6) trim screws and gun grade mastic 3288023 around the perimeter of the end cap.

ZL-16® Roof System Installation Guide

9.17.8 INSTALL OUTSIDE CORNER BOX AND END CAP TO RIB CONCEALING (HC) GUTTER

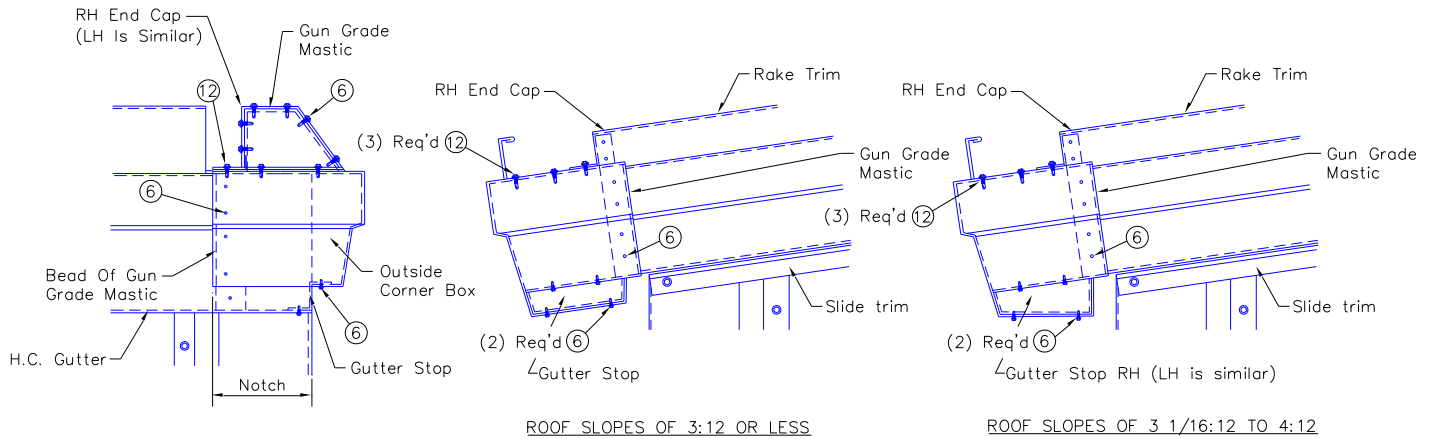

Before installing outside corner box, install the gutter stop using (2) ⑥ screws.

Field notch the slide trim to clear the bottom lip of the outside corner box.

Field cut the top and front of the outside corner box to fit the corner.

Install outside corner box using (8) ⑥ trim screws and gun grade mastic 3288023 along the front and top surfaces.

Place (3) ⑥ self-drilling screws through top of outside corner box and top lip of gutter end cap.

Install the (RH) or when applicable (LH) end cap with (9) ⑥ trim screws and gun grade mastic 3288023 around the perimeter of the end cap.

9.17.9 FINISHING RIB CONCEALING GUTTER TO RAKE, AT CORNER

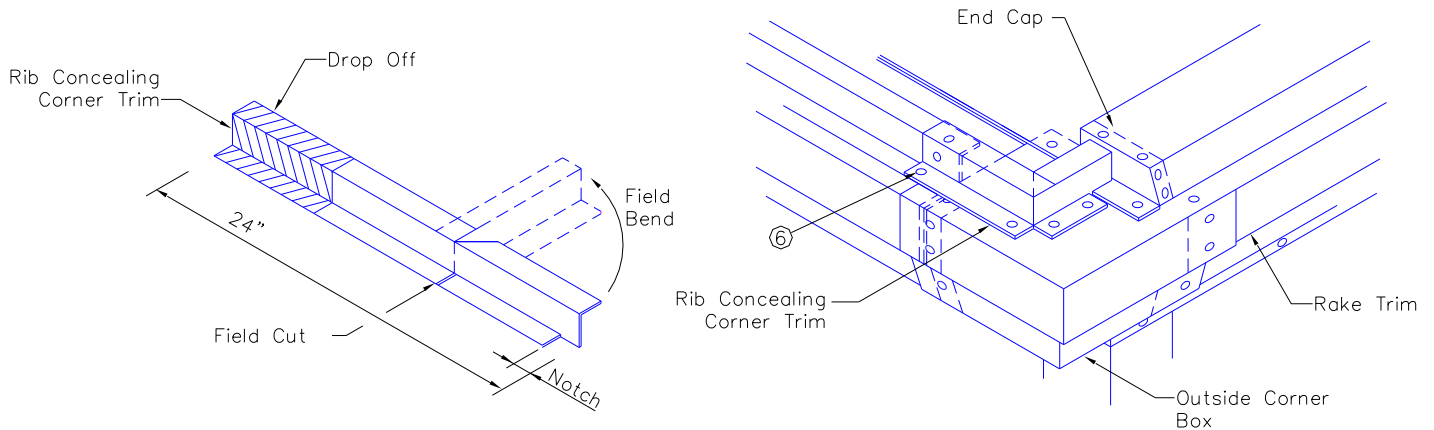

The corner will be finished by field cutting and bending a portion of the rib concealing corner trim, then attaching with (6) ⑥ trim screws.

ZL-16® Roof System Installation Guide

10 DOWNSPOUT INSTALLATION

10.1 LOCATING DOWNSPOUTS

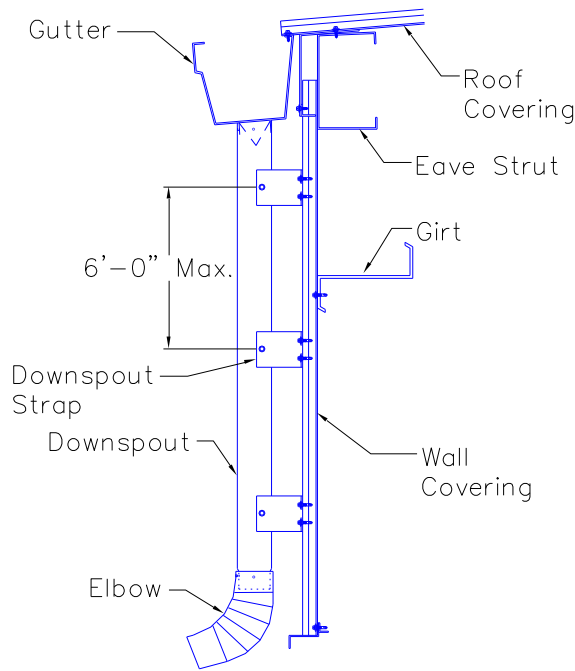

The appearance of the downspouts will have a critical effect on the appearance of the project. Keep the downspouts perpendicular with the gutter when installing.

Proper downspouts are necessary to prevent gutter overflow and roof flooding. Refer to the erection drawings to determine the required downspout size and quantity.

10.2 CUTTING BOTTOM OF GUTTER AND ATTACHING DOWNSPOUT

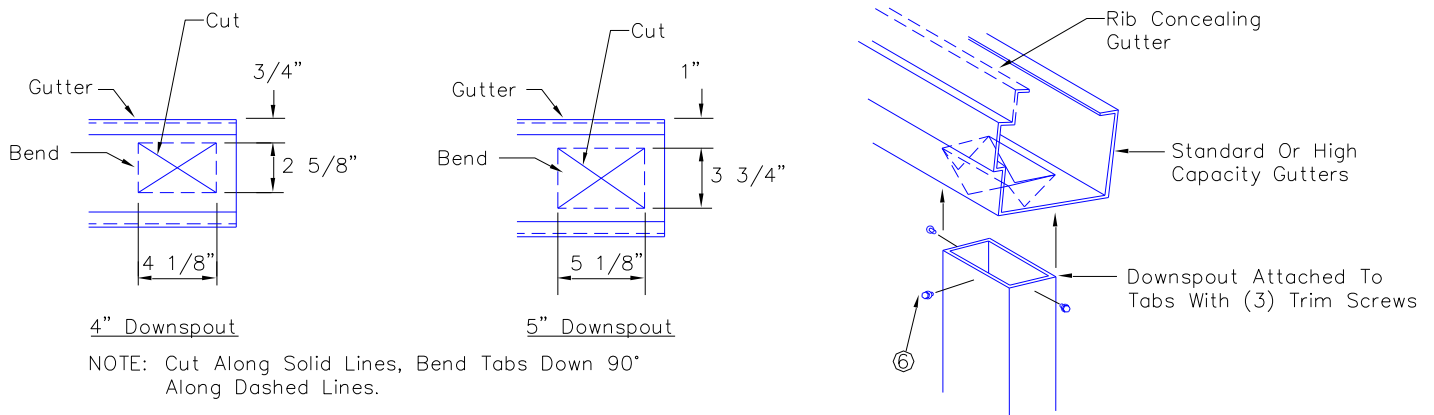

Once the spacing has been determined, cut and bend down tabs in the bottom of the gutter and attach downspout with (3) ⑥ trim screws.

ZL-16® Roof System Installation Guide

10.3 SPLICING DOWNSPOUTS

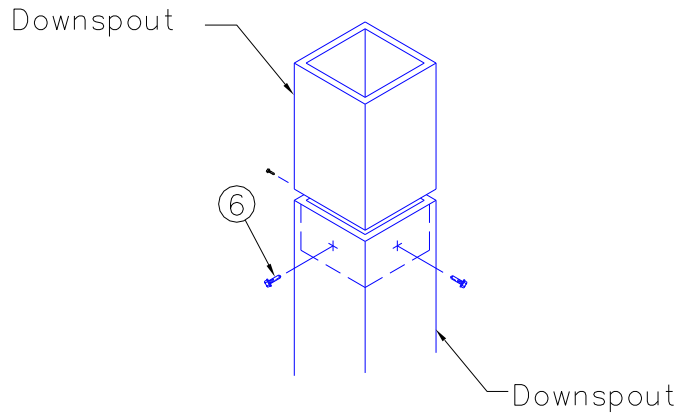

Splice downspouts by using (3) (6) trim screws.

10.4 SECURING DOWNSPOUT TO WALL

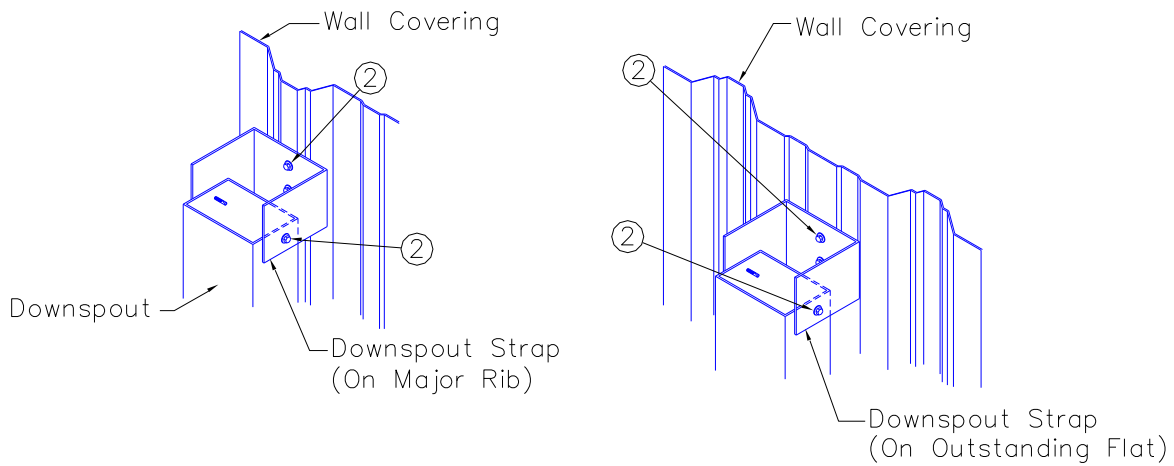

Downspout locations should be located at a major rib or the flat of the panel, depending on the style of wall panel. See above details for reference. Downspouts will be secured to the wall with a strap at a 6'-0" maximum spacing. Straps will be attached to the wall and downspout with a total of 4 (2) self-drilling screws.

10.5 INSTALL ELBOW

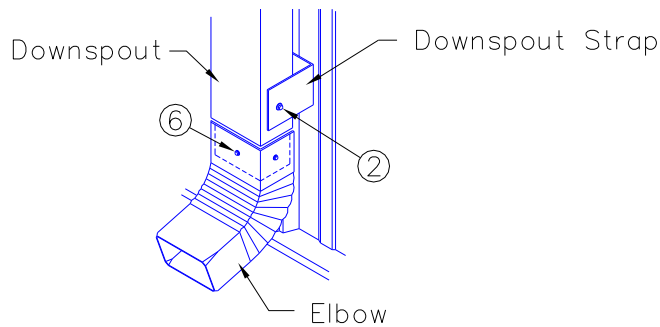

Attach elbow by using (3) (6) trim screws.

ZL-16® Roof System Installation Guide

11 ROOF ACCESSORIES

11.1 PRE-VENT® (LOW PROFILE) RIDGE VENTILATION SYSTEM

The use of the Pre-Vent ridge ventilation material at the ridge to exhaust hot air must be balanced with vent intake at eave or soffit. Since ventilation requirements vary per job, the method for air intake is not dealt with by the bldg mfr. the customer should consult a mechanical engineer for his specific job requirements.

The Pre-Vent ventilation material can be installed as a single 10 ft. unit or butted together to form a continuous run but must stop a minimum of 1 ft. from the endwall in order for peak flashing to be installed.

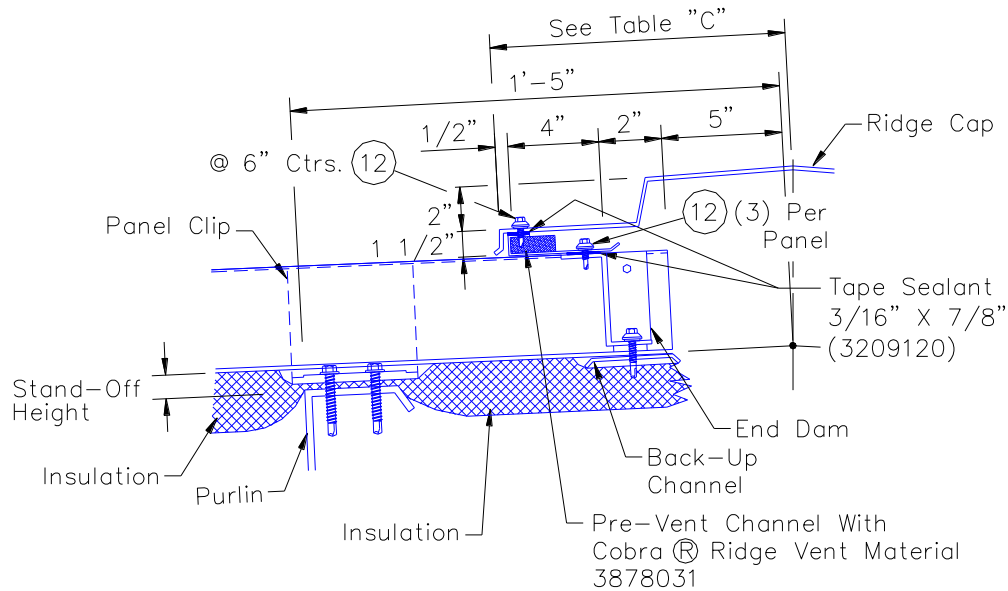

11.1.1 MODIFICATIONS TO RIDGE COMPONENTS

Where the Pre-Vent ridge ventilation material is located along the ridge the standard ridge caps. (See page 37) will be replaced with a different ridge cap that has been specifically detail for the roof slope used on the job. See erection plans for these part numbers and locations.

ZL-16® Roof System Installation Guide

11.1.2 RIDGE PANEL OVERHANG VERIFICATION

Unless noted otherwise on the erection plans the roof panel and the end dam location will be one of the applicable dimensions shown in TABLE C below.

ROOF SLOPE	TABLE C DIMENSION	
	3/8" STAND-OFF	1 3/8" STAND-OFF
1/4: 12	1'-0 1/8"	1'-0 1/16"
1/2: 12	1'-0 3/16"	1'-0 1/8"
1 : 12	1'-0 7/16"	1'-0 5/16"
2: 12	1'-0 13/16"	1'-0 5/8"
3: 12	1'-1 1/4"	1'-1"
4: 12	1'-1 5/8"	1'-1 5/16"

RIDGE CAP

- 26 Ga. Precoated Or Galvalume Material
- Roof Color
- 20'-6" Length

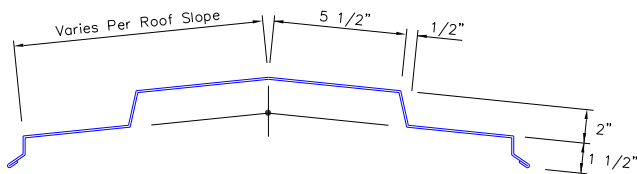

Part No. (See Plans)

PRE-VENT 10 FT. RIDGE VENT

- 24 Ga. Galvalume Channel
- Cobra® Ridge Vent Material
- 10 Ft. Length

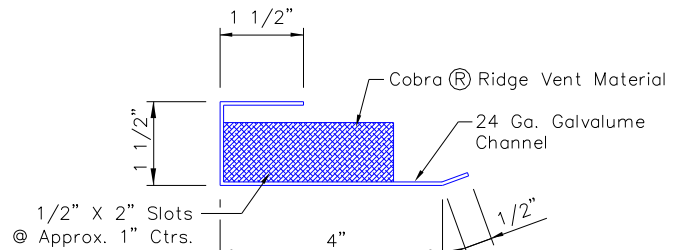

Part No. 3878031

LH SIDE END CAP

- 26 Ga. Precoated Or Galvalume Material
- Roof Color
- Roof Slope Of 1/2:12

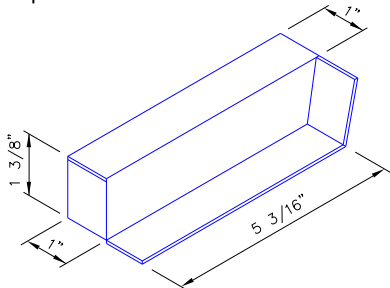

Part No. TM127

RH SIDE END CAP

- 26 Ga. Precoated Or Galvalume Material
- Roof Color
- Roof Slope Of 1/2:12

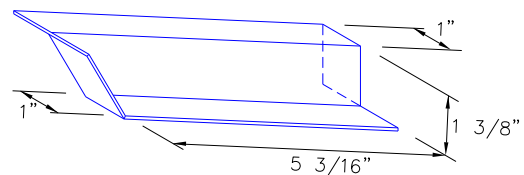

Part No. TM128

END CAP LH

- 26 Ga. Precoated Or Galvalume material
- Roof Color
- Roof Slope 4:12 Or Less

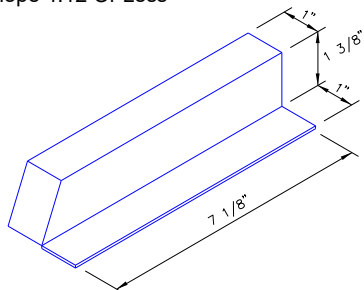

Part No. TM125

END CAP RH

- 26 Ga. Precoated Or Galvalume Material
- Roof Color
- Roof Slope 4:12 Or Less

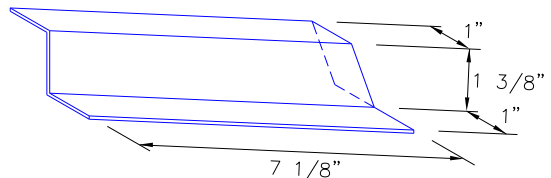

Part No. TM126

8/29/08

ZL-16® Roof System Installation Guide

11.1.3 INSTALL BACK-UP CHANNEL AND END DAMS

For installation of back-up channels, see section 9.8

For installation of end dams, see section 9.8

11.1.4 INSTALL PRE-VENT® MATERIAL

After placing 3/16" x 7/8" tape sealant along the top lip of the end dams, position the Pre-Vent channel 4" beyond the web of the end dam and secure with ⑫ self-drilling screws as shown below.

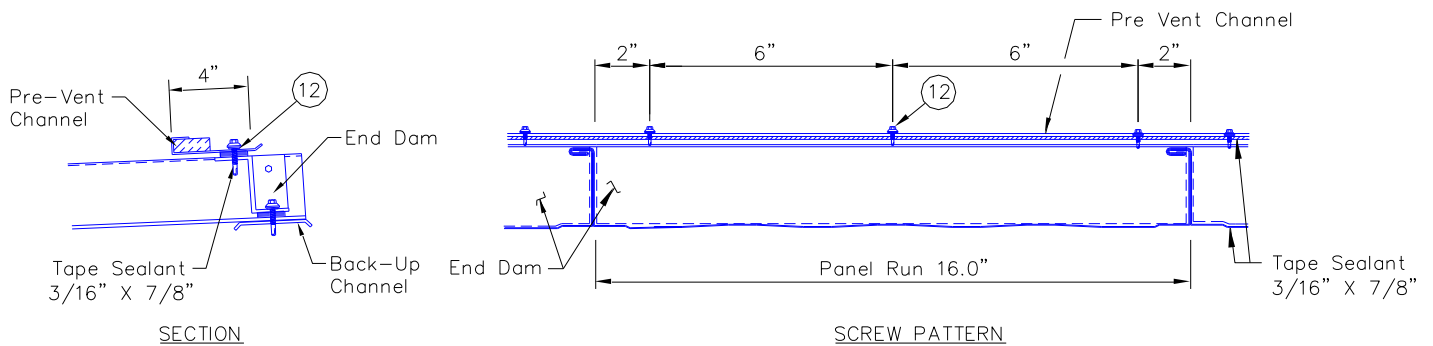

11.1.5 INSTALLING RIDGE CAP

After placing 3/16" x 7/8" tape mastic along the top lip of the Pre-Vent channel, position the ridge cap, as shown below, and secure with ⑫ self-drilling screws at 6" centers.

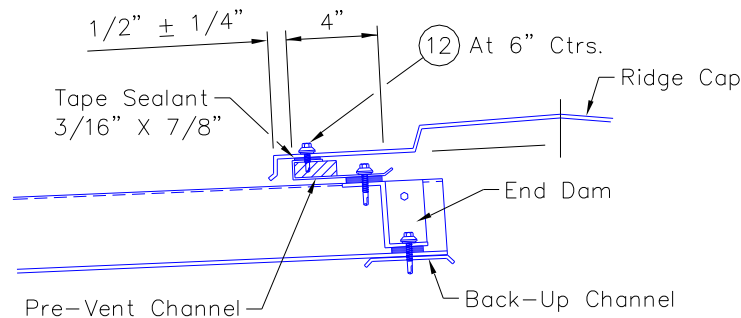

When continuous ridge vents are being installed, butt ends of Pre-Vent channels and stop the run of vents a minimum of 1 foot from the endwall in order for the standard ZL-16 peak flashings to be installed, see Section 9.13.

ZL-16® Roof System Installation Guide

11.1.6 INSTALL END CAPS AT END OF RUN

The following components will be used to make the transition from the end of ridge ventilation system to the standard ridge cap.

- A. LH End Cap TM125 for roof slopes of 4:12 or less
- B. RH End Cap TM126 for roof slopes of 4:12 or less
- C. LH Side End Cap TM127 for roof slopes of 1/2: 12 or less.
For roof slopes greater than 1/2: 12 see plans.
- D. RH Side End Cap TM128 for roof slopes of 1/2: 12 or less.
For roof slopes greater than 1/2: 12 see plans.
- E. Gun Grade Mastic 3288023
- F. ⑫ screw 1/4 x 3/4 LG-LF SD WW (3288103)

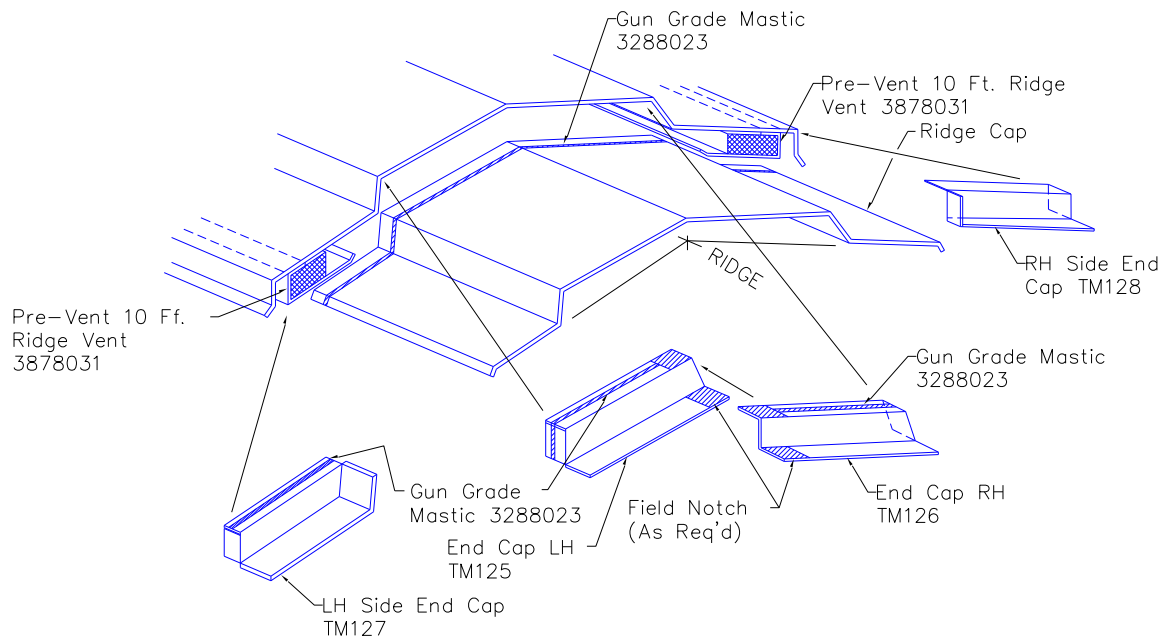

PARTIAL ASSEMBLED

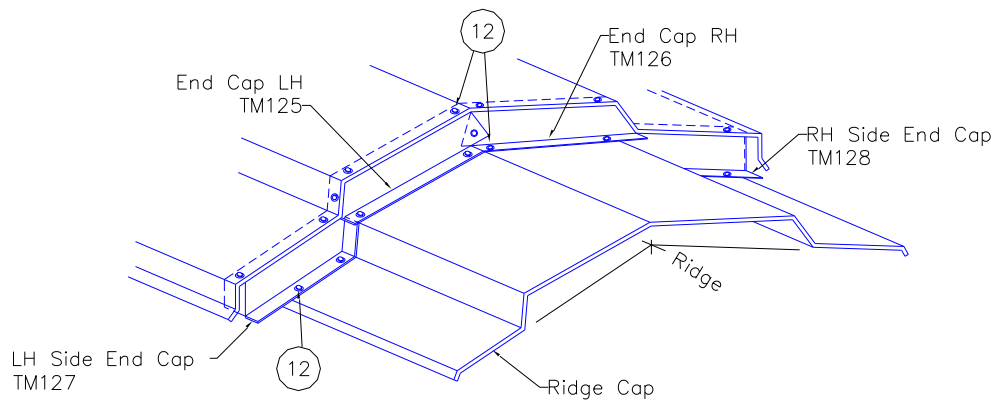

ASSEMBLED

ZL-16® Roof System Installation Guide

11.2 PIPE FLASHING

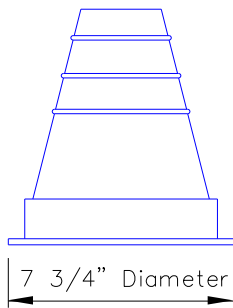
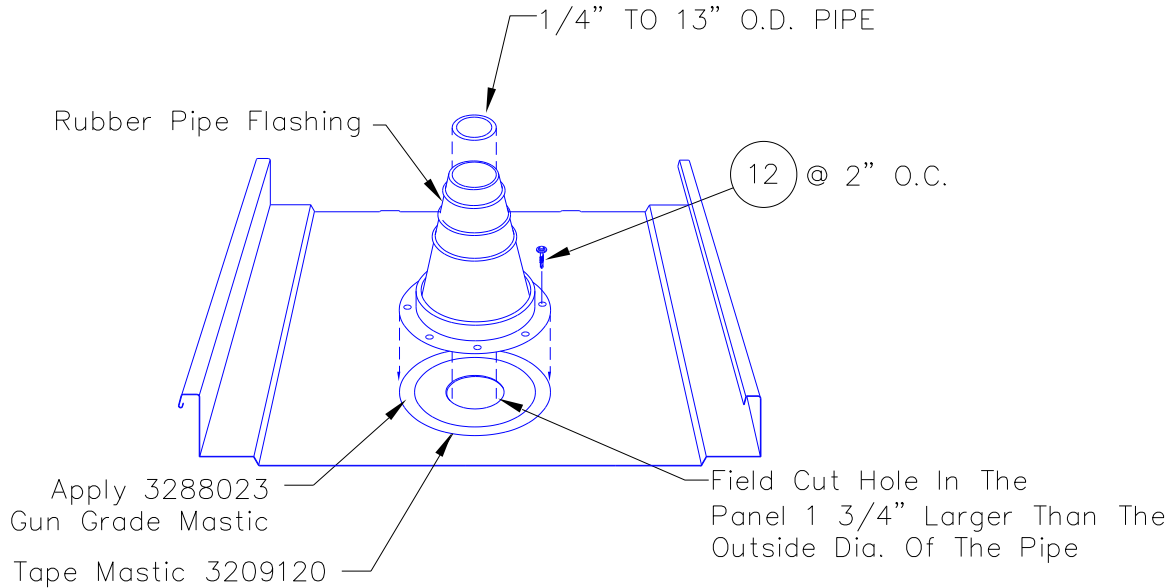

2368-004 PIPE FLASHING
FOR PIPES WITH O.D. OF
1/4" TO 4"

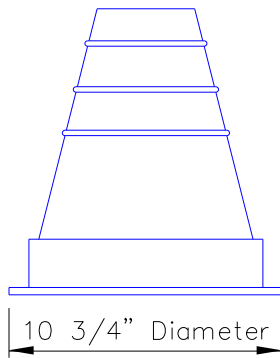

2368-005 PIPE FLASHING
FOR PIPES WITH O.D. OF
4" TO 7"

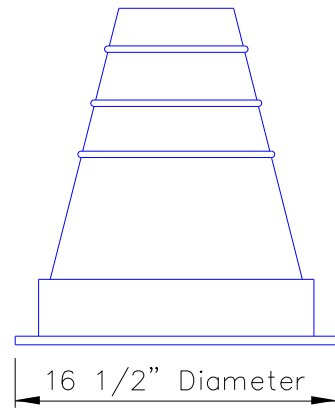

2368-006 PIPE FLASHING
FOR PIPES WITH O.D. OF
7" TO 13"

GENERAL NOTES FOR PIPE FLASHING INSTALLATION:

1. CUT A NEAT HOLE IN THE ROOF PANEL WITH A MINIMUM CLEARANCE OF 1 3/4" ALL THE WAY AROUND THE PIPE. AVOID CUTTING THE MAJOR RIB ON THE PANEL.
2. CLEAN THE ROOF PANEL AROUND THE HOLE.
3. IF THE RUBBER PIPE FLASHING HAS TO BE CUT TO SUIT THE PIPE SIZE USE A SHARP PAIR OF SCISSORS AND AVOID NICKS.
4. APPLY TAPE MASTIC TO ROOF PANEL
5. APPLY GUN GRADE MASTIC TO TOP OF TAPE MASTIC OR UNDERSIDE OF THE PIPE FLASHING AND ATTACH TO THE ROOF PANEL AS SHOWN BELOW.
6. WHEN ATTACHING THE SCREWS THE FIRST (2) SCREWS SHOULD BE OPPOSITE EACH OTHER. THEN PROGRESSIVELY COMPLETE THE FASTENING BY PRESSING THE BASE DOWN FIRMLY.

6/10/24

ZL-16® Roof System Installation Guide

11.3 ROOF CLAMP

When the roof clamp (Part no. 1508149) is to be used on the standing seam roof, the following erection procedure can be used.

STEP NO. 1

At the location where the clamp will be installed the panel seam must have been TRIPLE-LOCK manually seamed in order to allow the placement of the roof clamp.

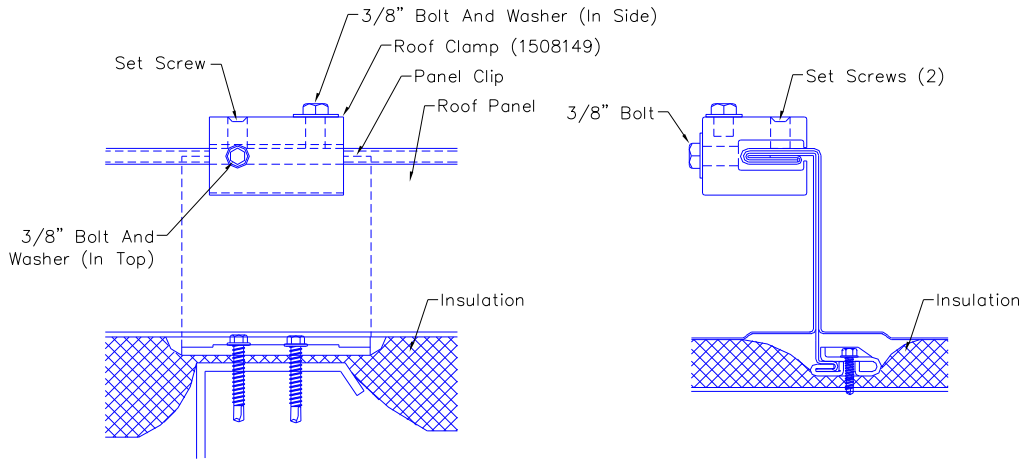

ROOF CLAMP ON TRIPLE-LOCK SEAMED ROOF

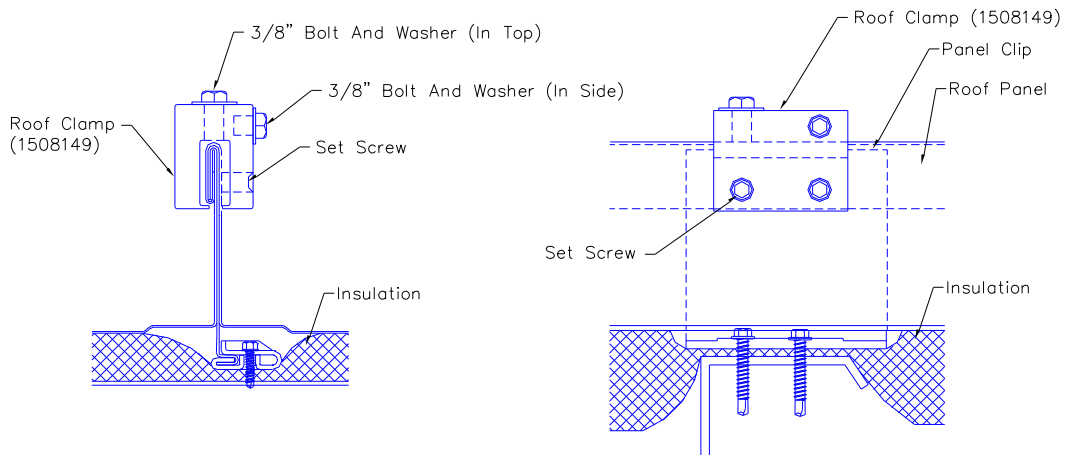

ROOF CLAMP ON QUADRI-LOCK SEAMED ROOF

STEP NO. 2

Position the clamp base over the panel seam, and then tighten both set screws. Use the 3/8" dia. bolt to attach other components either in the top or side of the clamp.

ZL-16® Roof System Installation Guide

12 ROOF SEAMING GENERAL INFORMATION

12.1 GENERAL

This information is provided to customers and erectors as the recommended procedures for the correct seaming of the ZL-16® Standing Seam Roof System.

This information is intended to be used with the project's erection drawings.

The erection drawings govern the specific seam requirements. In case of conflict between this information and the erection drawings, the erection drawings will have precedence.

The customer is responsible for proper seaming of the roof in accordance with the erection drawings and this seaming information, and in accordance with good engineering and construction practices.

The customer must take the responsibility for selecting a competent erector, insist that the work be performed by qualified and experienced standing seam metal roof installers, insist that the erector take time to study and understand this information, then assure that the erector correctly follows these instructions.

The building manufacturer does not guarantee and is not liable for the quality of erection. The building manufacturer is not responsible for building defects that may be attributed to improper erection or the negligence of other parties.

Clarification concerning the roof installation and seaming should be directed to the building manufacturer's customer service manager.

12.2 SEAM TYPES

12.2.1 GENERAL

The ZL-16® Standing Seam Roof System has two seam type options. The project's design and roof performance requirements govern which seam type is required.

Different seam types may be required on specific areas of the roof. In all cases, refer to the erection drawings to determine the required seam type and location.

Different seams can be achieved through two different methods:

1. Manual seaming with hand tools.
2. Limited manual seaming followed by running motor seaming machine.

12.2.2 TRIPE – LOCK SEAM

The Tripe – Lock Seam requires seaming the roof panels with the manual seaming tool at the panel clips, at the eave and ridge ends of the panel, and at the endlaps. Then seam the entire roof, the full length of the panels, with a motor seaming machine.

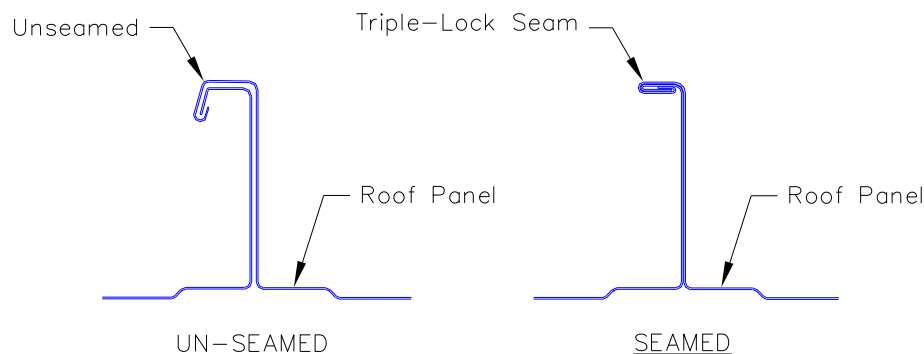

ZL-16® Roof System Installation Guide

12.2.3 QUADRI – LOCK SEAM

Prior to Quadri – Lock seaming, the entire seam must have been Triple – Lock seamed. Then the Quadri – Lock seam requires seaming the specified area of the roof with a manual seaming tool. The motor seaming machine from our recommended seamer supplier can seam a triple and quadri-lock seam in one pass.

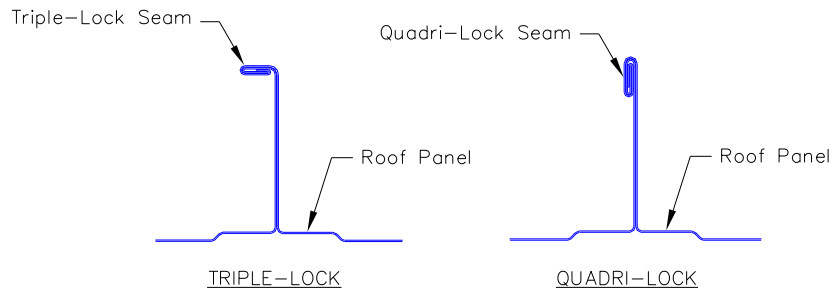

12.3 CHECK PANEL ASSEMBLY

12.3.1 SIDELAP FIT-UP

Before seaming, inspect the full length of each roof panel sidelap. Check that the male and female are fully nested and the lip at the panel's male edge is enclosed by the hook of the adjacent panel's female edge.

Any conditions where the male and female are not fully nested or the male lip is not positioned inside of the female hook must be corrected before attempting to seam the roof panels.

Caution: Faulty seaming may occur where the male lip is not enclosed by the female hook and when the male and female are not fully nested. Such faulty seaming can result in seaming difficulty and objectionable seam appearance. In severe cases reduction in roof performance specifications.

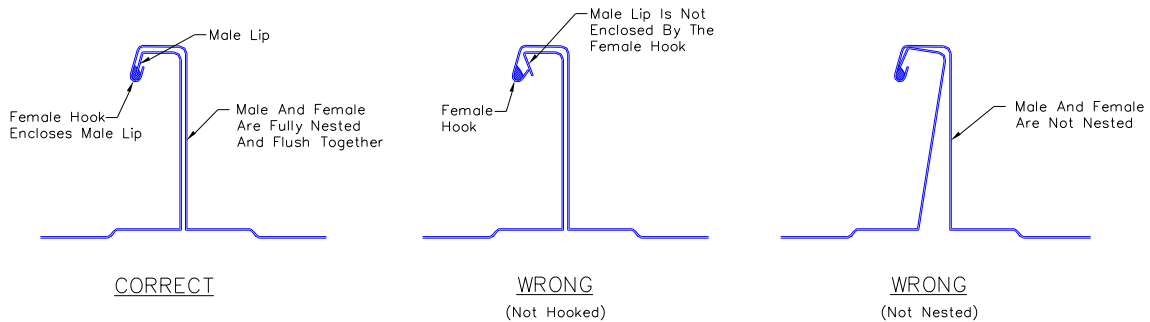

12.3.2 CLIP ALIGNMENT

Before seaming, check that each roof panel clip is properly seated in the roof panel sidelap assembly. Any displaced clips must be corrected before attempting to seam the roof panels.

Caution: Misaligned panel clips can cause faulty seaming and objectionable seam appearance.

12.3.3 SEAM DAMAGE

Before seaming, check that the male and female edges are not kinked or otherwise distorted. Any such distortions must be corrected before attempting to seam the roof panels.

13 IMPORTANCE OF SEAMING

13.1 ROOF PERFORMANCE

The roof panels must be correctly seamed before the roof system can provide its designed wind load and weather resistance capability. This means that an un-seamed roof is subject to wind load failure and/or weather resistance failure.

13.2 WHEN TO SEAM

Whenever possible, the installed roof panels should be seamed at the finish of each day's work. If high wind or rain/snow conditions are imminent, the installed roof panels must be seamed before such conditions occur.

ZL-16® Roof System Installation Guide

13.3 TEMPORARY SEAMING

On roofs requiring Triple-Lock and Quadri-Lock seams, it may not always be practical or feasible to motor seam the roof panels until after the roof installation is completed. Motor seamed roof panels are difficult to reposition or replace and seaming machines may not always be available during the entire roof installation period.

In such cases, it may be desirable to temporarily Triple-Lock seam the roof panels at the roof panel ends and the panel clip locations with the manual seaming tool, then later complete the seaming with the motor seaming machine.

Important: Temporary Triple-Lock seaming must be approved by the project's designer.

14 SEAMING EQUIPMENT

14.1 SPECIALIZED SEAMING TOOLS

The seaming of the roof panels requires special seaming tools which are available only from the building manufacturer. The roof system seaming tools are custom built, specialized equipment and are costly to replace.

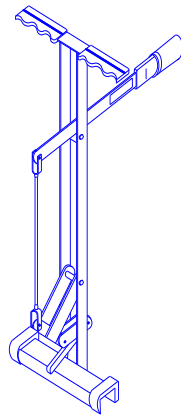

Stand-Up Seaming Tool
255139

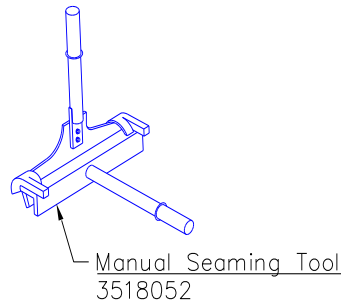

Manual Seaming Tool
3518052

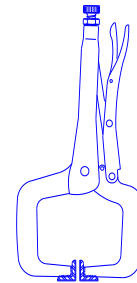

Rib Clamp
255143

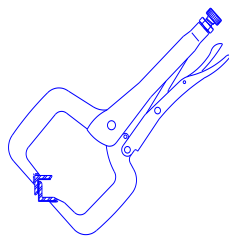

Seam Clamp 255133

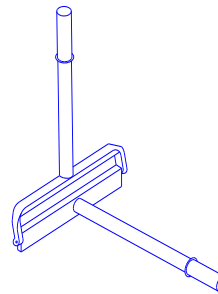

Quadri-Lock Seaming Tool 3518053

14.2 SEAMING TOOL SOURCE

The tools (above) specifically designed for the standing seam roof panel are available from the building manufacturer.

ZL-16® Roof System Installation Guide

14.3 MOTOR SEAMING MACHINES

Two different models of seamers are available from the company below. Seamers can be ordered through the Quality Roof Seamers website www.qualityroofseamers.com and selecting Behlen Building Systems in the “Our Manufacturers” selection.

Quality Roof Seamers, Inc. 8265 Highway 178 Olive Branch, MS 38654 Phone: 662-895-1222 Fax: 662-890-4775	
---	---

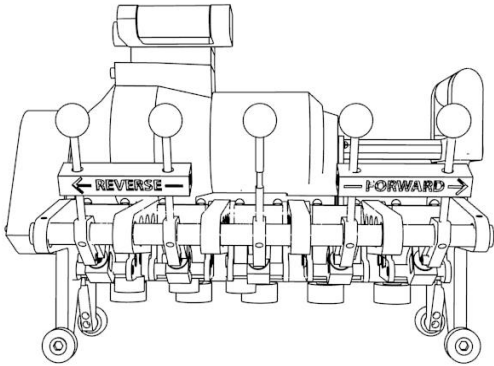

MODEL: 5 STATION TRIPLELOK

Features: Weight = 60lbs.
Speed = 30 feet per min.

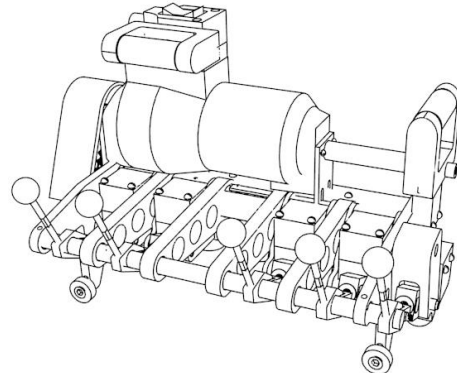

MODEL: 5 STATION QUAD LOK

Features: Weight = 60lbs.
Speed = 30 feet per min.

Specific operation, care and use of the seamer will be included in an instruction manual shipped with seamer.

Upon completion of the roof seaming, promptly return the seaming kit in accordance with the instructions on the return shipping documents. The return shipping documents are provided in the seaming kit.

14.4 HANDLING SEAMER

Provide safe and secure handling of the seaming tools when in use.

The weight of the seaming machines are 60 pounds and can cause damage and injury if it falls.

The machines may be too heavy to safely carry up a ladder. Always hoist the machines onto the roof with proper lifting equipment or with a proper sized rope tied or hooked securely to the machine’s front lifting handle.

When starting and finishing the seaming machine at the edges of the roof, the operator must be securely positioned so that he can safely lift the seaming machine on and off of the seam.

Caution: The use of other seaming equipment may result in faulty and/or damaged seams and may invalidate the roof system’s material and performance warranties.

ZL-16® Roof System Installation Guide

15 ELECTRICAL REQUIREMENTS

15.1 MOTOR SEAMING MACHINES

The seaming machine motor requires a 10 amp, 100-125 volt AC power supply.

15.2 ELECTRICAL SERVICE AND CORDS

The electrical service and the electrical cords to the seaming machine must be of sufficient capacity to provide electrical power **at the seaming machine**. If other tools or equipment are being used on the same service, the service and cord capacity must be increased accordingly.

Caution: Low voltage due to insufficient service capacity, insufficient cord size or excessive cord length will cause overheating and burnout of the seaming machine's motor.

15.3 ELECTRICAL SAFELY

Check that the power cords are fitted with the correct plug for safe and secure electrical connection to the seaming machine. Check that the power cords are properly grounded and that the service has a ground fault circuit breaker.

15.4 CORD CLEARANCE

Check that the electrical cord is of sufficient length to extend the full length of the area to be seamed without stress on the cord or its connections. Check that the path for the cord is clear and that the cord is clear of snagging on panel edges or entanglement into the seaming machine rolls.

16 MANUAL SEAMING TOOL OPERATION

16.1 MANUAL SEAMING TOOL TYPES AND NOMENCLATURE

The following detail identifies the operational parts of the manual seaming tool and the stand-up seaming tool.

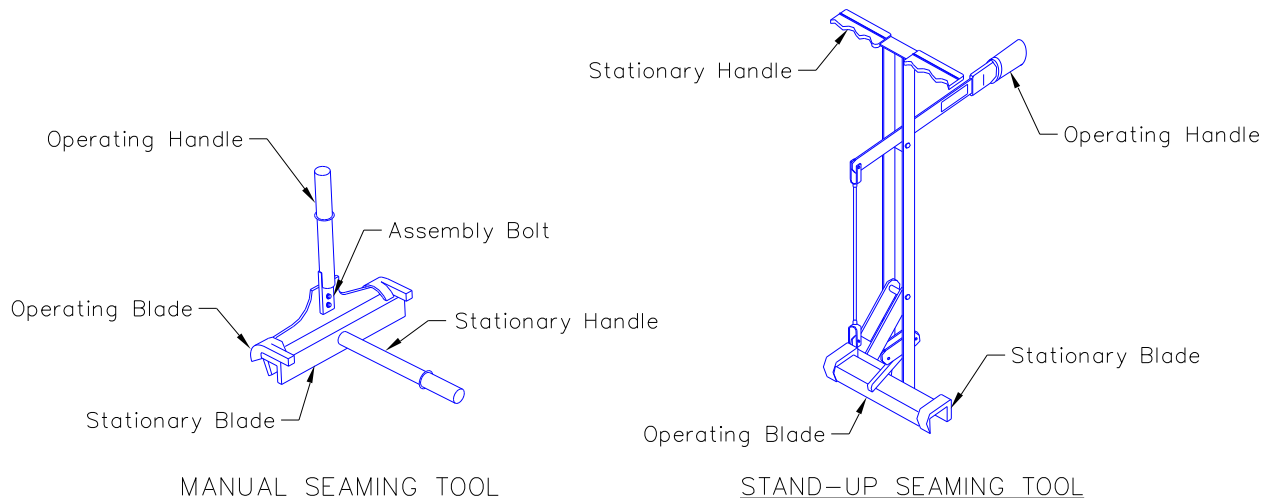

Throughout the rest of this seaming tool operation, only the manual seaming tool will be shown. The information is similar for the stand-up seaming tool.

ZL-16® Roof System Installation Guide

16.2 TOOL ORIENTATION TO SEAM

Orient the tool to fit correctly onto the roof panel seam as shown. The stationary handle must be in the horizontal position and the operating handle must be rotated up to the open position.

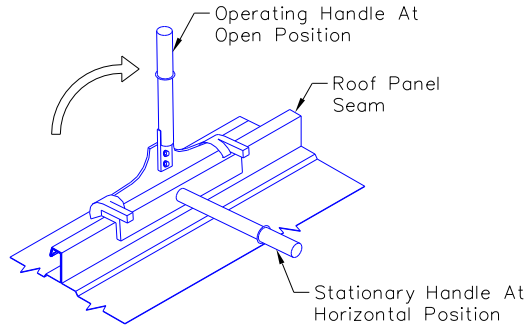

16.3 FORMING THE SEAM

When the tool is correctly positioned on the panel, push the stationary blade down solidly against the top of the seam. While holding the stationary handle in the horizontal position, rotate the operating handle down to the horizontal position.

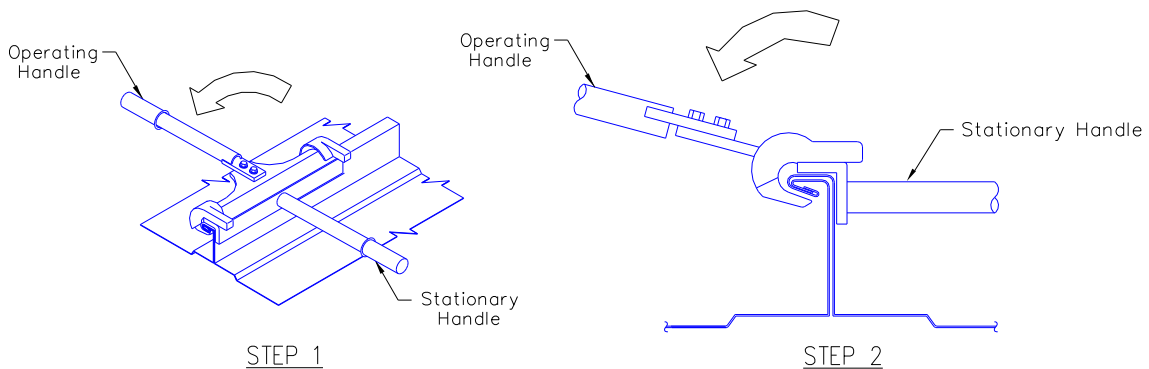
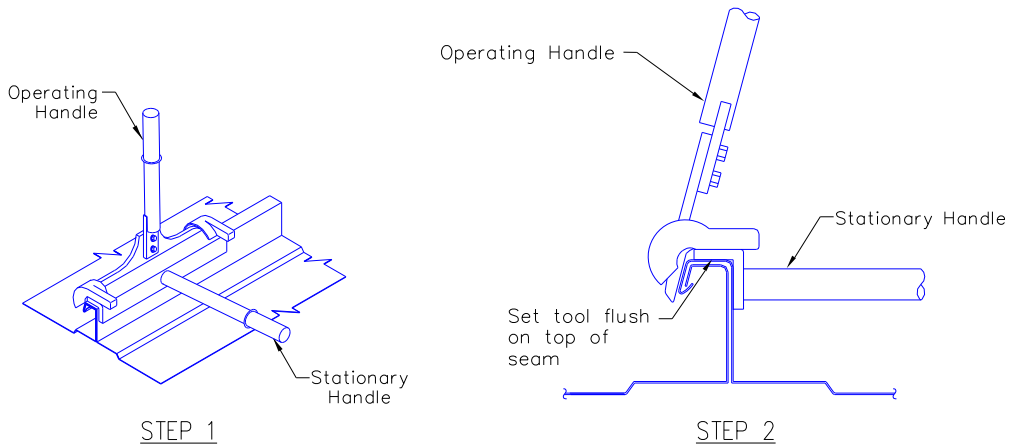

ZL-16® Roof System Installation Guide

16.4 TOOL POSITION AT END OF PANEL

When seaming at the eave or ridge end of the roof panel, the seaming must be done in two steps.

For the first step, position the end of the seaming tool at 6" from the end of the roof panel and seam that area.

For the second step, position the end of the seaming tool flush with the end of the roof panel and seam that area.

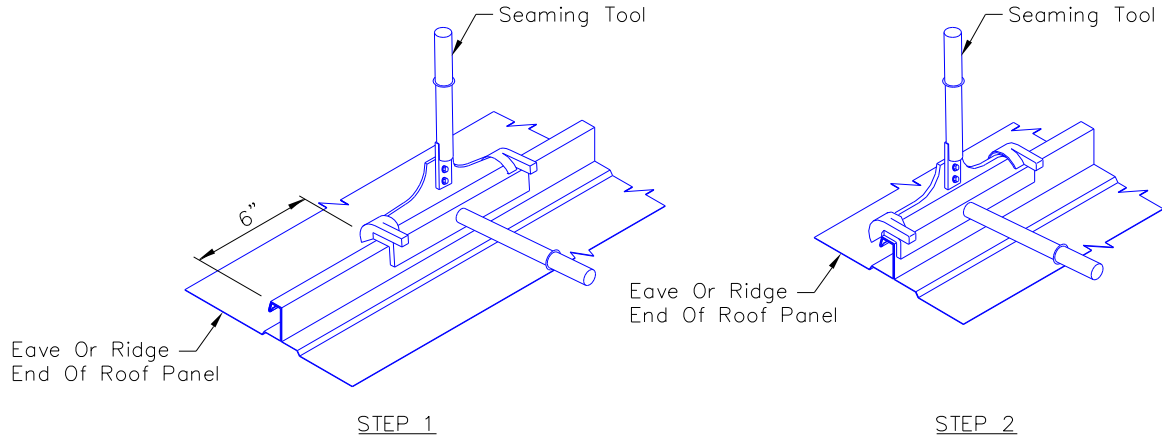

16.5 TOOL POSITION AT PANEL ENDLAP

When seaming at a roof panel endlap, the seaming must be done in two steps.

For the first step, center the tool over the endlap and seam that area.

For the second step, position the end of the tool 3" uphill from the edge of the endlap and seam that area.

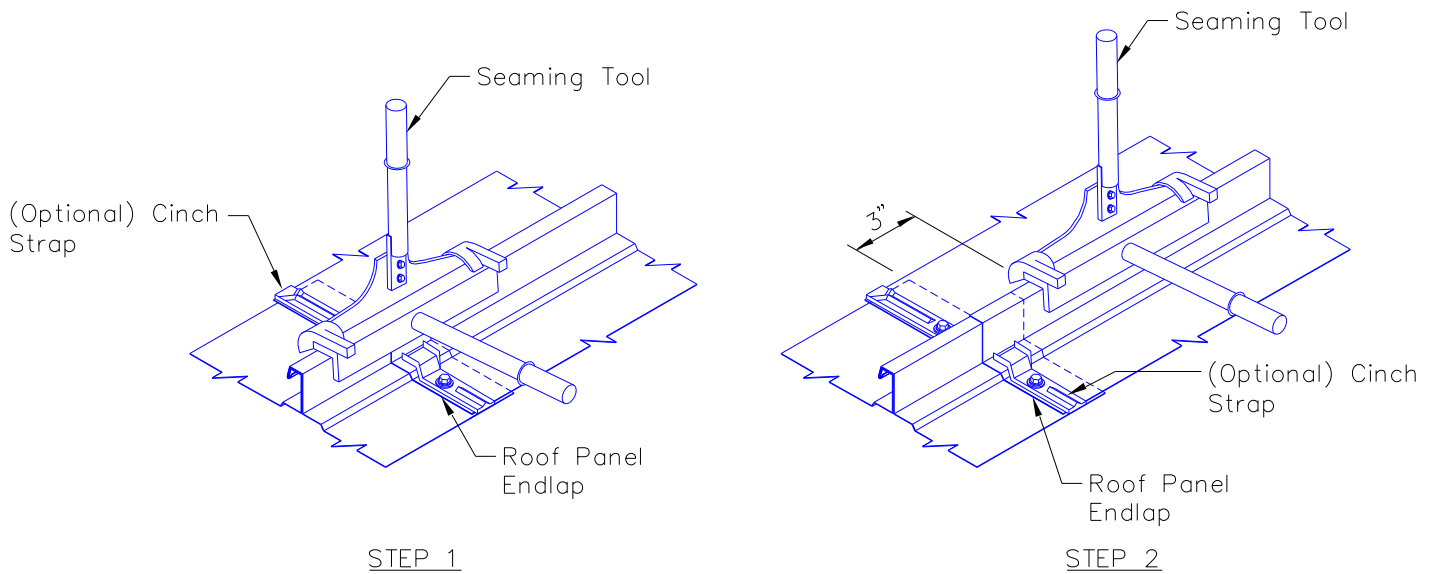

ZL-16® Roof System Installation Guide

16.6 TOOL POSITION AT PANEL CLIPS

When seaming at a panel clip location, center the tool over the panel clip and seam that area.

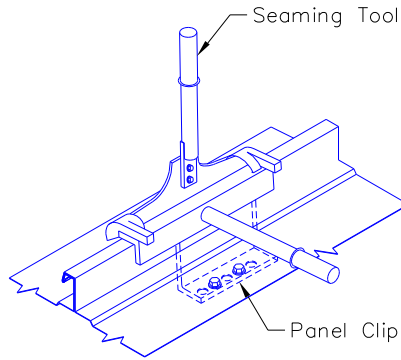

AT PANEL CLIP LOCATIONS

16.7 CHECKING THE FINISHED SEAM

Rotate the operating handle to the open position, remove the tool and check that the seam is correctly formed, as shown on the detail below.

Caution: If the manual seaming tool does not correctly form the seam, do not continue seaming but contact the building manufacturer for instructions.

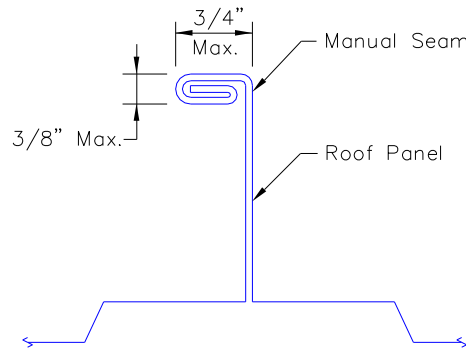

SECTION

This manual seaming operation will have an effect on the appearance, from the side, of the panel seam.

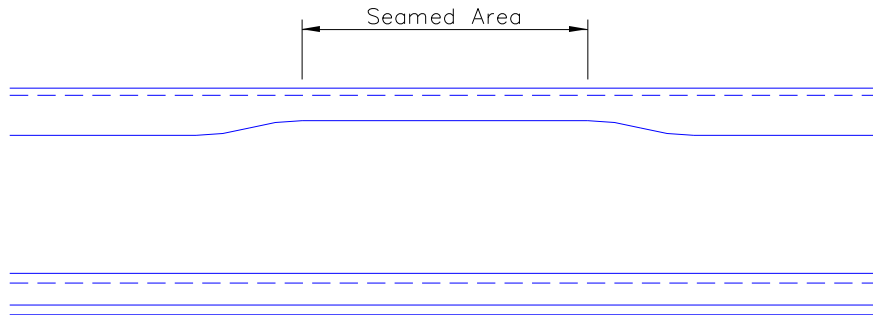

SIDE VIEW

ZL-16® Roof System Installation Guide

17 QUADRI-LOCK MANUAL SEAMING TOOL OPERATION

17.1 TOOL NOMENCLATURE

The QUANDRI-LOCK manual seaming tool is a lever operated field forming tool. The tools blades are designed to form the panel seam into the QUANDRI-LOCK seam profile. The tools handles are long enough to allow stand-up operation.

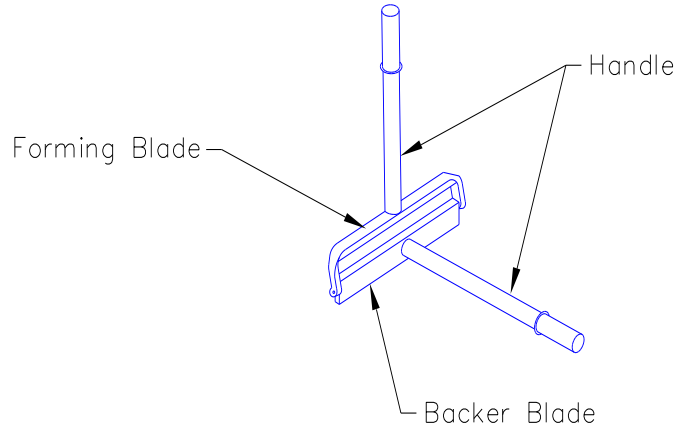

MANUAL QUANDRI-LOCK SEAMING TOOL

17.2 TOOL ORIENTATION TO SEAM

Step No. 1

To begin, simply spread the handles to open the forming jaws making sure that the female notch in the forming blade is set properly over the seam that has been previously Triple-Locked. Close the handles to form the seam.

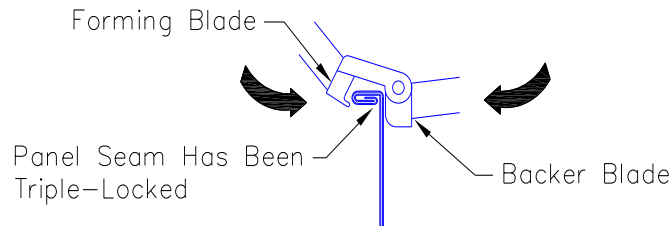

POSITIONING TOOL OVER SEAM

Step No. 2

Rotate hand seamer so the flat backer blade is against the formed part of the seam and close the handles to complete the Quadri-Lock seam.

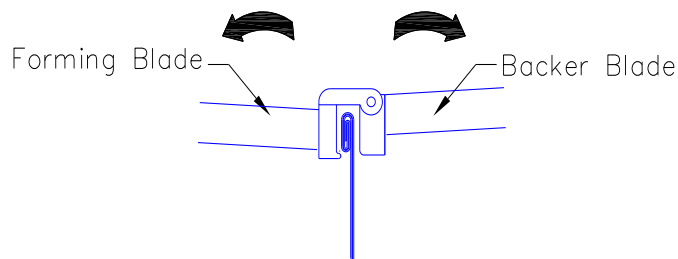

FLATTENING SEAM

ZL-16® Roof System Installation Guide

17.3 CHECKING THE FINISHED SEAM

Rotate the operating handles to the open position, remove the tool and check that the seam is correctly formed as shown below.

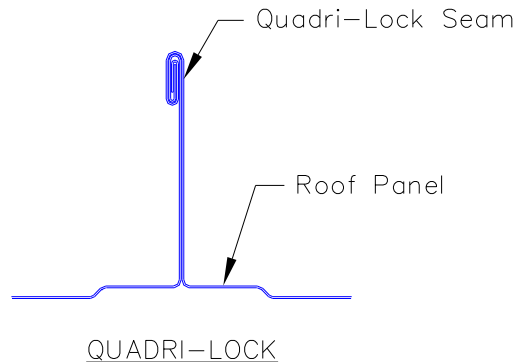

18 MOTOR SEAMING MACHINE OPERATION

Prior to running a seamer, read instructions included in seaming kit.

18.1 CLEAN THE SEAMS

The roof panel seams must be thoroughly cleaned of abrasive dirt or dust that can cause scuffing or scratching of the seam surface. The roof panel seams must be cleaned of grease or other contaminants which can cause seaming machine slippage and marking of the seam surface.

18.2 RUNNING THE SEAMER

Use caution when working or approaching the end of the panel with a seamer. Stop or start the seamer while wheels remain on the panel. DO NOT run to within 6 inches of the panel end, use the hand crimper.

Run the seamer about 4 to 6 inches and check seam to assure proper seaming operation. After seam is checked and proper operation is verified, seam remainder of the panel.

ZL-16® Roof System Installation Guide

19 TRIPLE-LOCK SEAMING

19.1 MANUAL SEAMING

Prior to motor seaming, use the manual seaming tool to close the seam at the eave and ridge ends of the panels, at the panel endlaps and at each clip.

19.2 MOTOR SEAMING

Seam the full length of each roof panel seam using the motor seaming machine which is fitted with the Triple-Lock forming rolls.

Start the seaming machine at the starting end of the seam, on the area previously seamed with the manual seaming tool.

If the roof panels have endlaps and the "Optional" cinch strap is used, stop the seaming machine just before running onto the endlap. Remove the seaming machine and restart it on the other side of the endlap on the area previously seamed with manual seaming tool.

Run the seaming machine to the finish end of the seams.

At any uncompleted seam areas, such as where the seaming machine had to be stopped prior to the endlap or ridge end dam, complete the seam with the manual seaming tool.

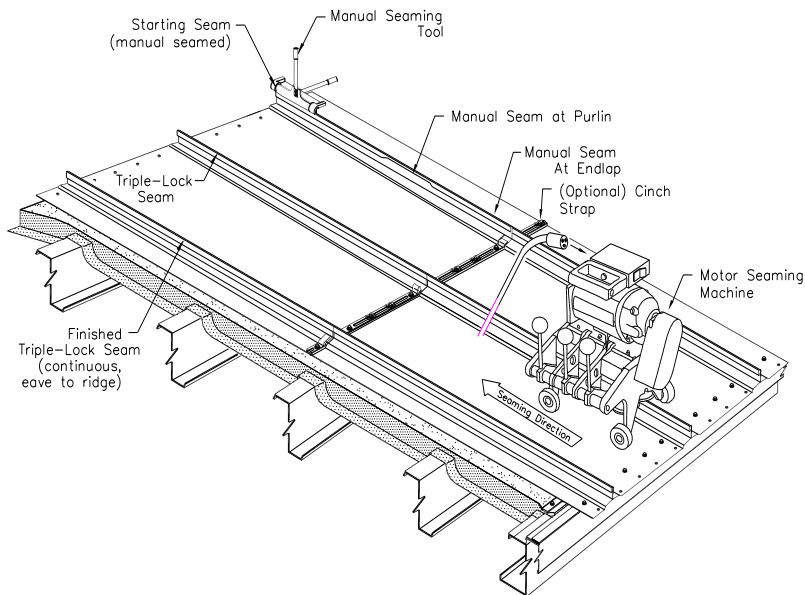

19.3 FINISH SEAM DETAIL

Check that the finished seam is correctly formed as shown in the following detail.

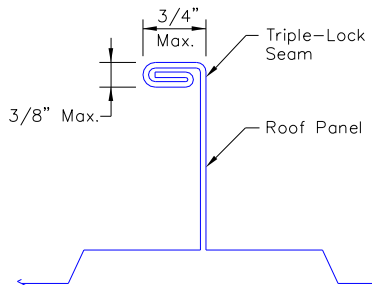

ZL-16® Roof System Installation Guide

20 QUADRI-LOCK SEAMING

To form a Quadri-Lock seam the manual seaming tool or a motor seaming machine can be used to seam the specified areas of the roof.

20.1 MANUAL SEAMING

Prior to motor seaming, use the manual seaming tool at the starting end of the seam where the rollers will be engaged.

20.2 MOTOR SEAMING

Seam the specified area of the roof using the motor seaming machine which is fitted with the Quadri-Lock forming rolls.

Start the seaming machine at the starting end of the seam, on the area previously seamed with the Quadri-Lock manual seaming tool.

If the roof panels have endlaps and the "Optional" cinch strap is used, stop the seaming machine just before running onto the endlap. Remove the seaming machine and restart it on the other side of the endlap on the area previously seamed with manual seaming tool.

At any uncompleted seam areas, such as where the seaming machine had to be stopped prior to the endlap or ridge end dam, complete the seam with the manual Quadri-Lock seaming tool.

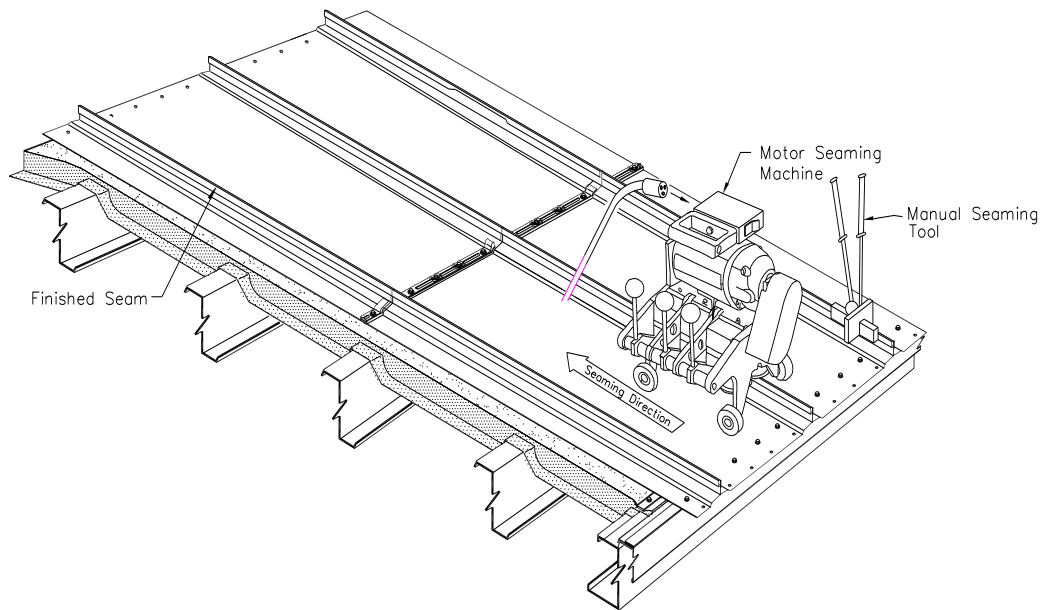

20.3 FINISH SEAM DETAIL

Check that the finished seam is correctly formed as shown in the following detail.

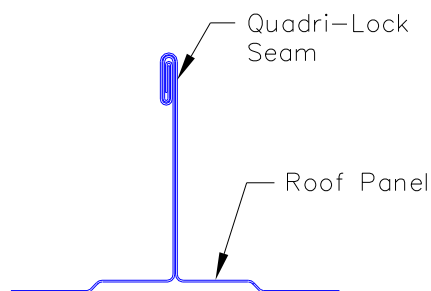

ZL-16® Roof System Installation Guide

21 PANEL REPLACEMENT PROCEDURE

21.1 GENERAL

The triple lock design provides the roof panel seams their remarkable resistance to opening under wind pressures. As forces try to pry open the first and second locks, the third lock actually tightens.

Understandably, opening the seam's three locks, such as required to replace damaged panels, will require a relatively complicated process.

Opening the seam involves a sequence of bending operations to progressively open each of the three locks. These bending operations must be done continuously along the full length of the seam with hand tools. This is necessarily a skill and labor intensive process. The labor cost of opening the seams must be considered when judging the trade-offs between panel replacement versus other options such as patch repairs, panel splicing or re-sheeting whole roof sections, etc.

To minimize the seam opening process required for roof panel replacement, the following procedures establish a start and finish seam on either side of the roof area where the roof panels are to be replaced. Only the start and finish seams will require the opening process, however all of the roof panels between the starting and finish seams will have to be replaced. Consideration must be given to the trade-off between the number of start and finish seams being opened versus the number of undamaged panels being replaced.

For example, one large panel replacement area will require only two seams to be opened at the expense of possible replacement of undamaged panels. Whereas, several small panel replacement areas may require a minimum replacement of undamaged panels but will require more seams to be opened.

During the opening and re-seaming process, the start and finish seams will be distorted and marred by the hand tools. The aesthetic acceptance and re-finishing (touch-up) requirements must be considered.

Following are suggested procedures for opening roof panel seams and replacement of roof panels in a given area.

21.2 DETERMINE THE DAMAGED PANEL AREA

Identify the damaged roof panels that are to be replaced. Select the roof panel seams that will define the starting seam and finish seam of the damaged panel area.

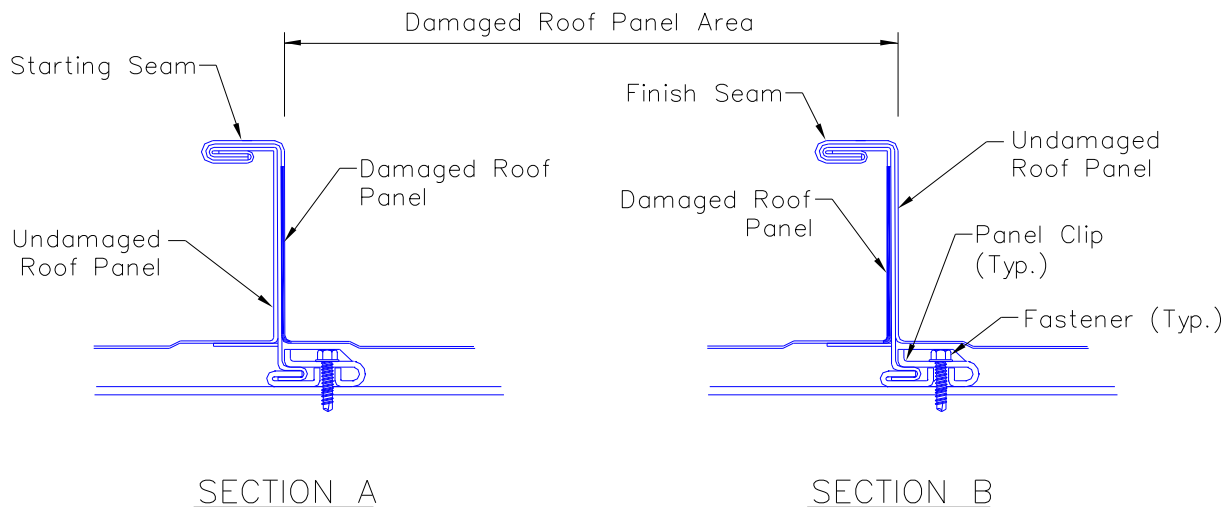

6/08/15

ZL-16® Roof System Installation Guide

21.3 REMOVE EAVE AND RIDGE ATTACHMENTS

Remove the eave fasteners and end dams from all of the roof panels in the area to be replaced and on the one undamaged roof panel that is adjacent to the finish point of the damaged panel area.

To remove the end dams, the ridge flashing or high eave flashing will have to be removed along the damaged panel area. If the roof has an eave gutter, the gutter will have to be detached from the roof panels along the damaged panel area.

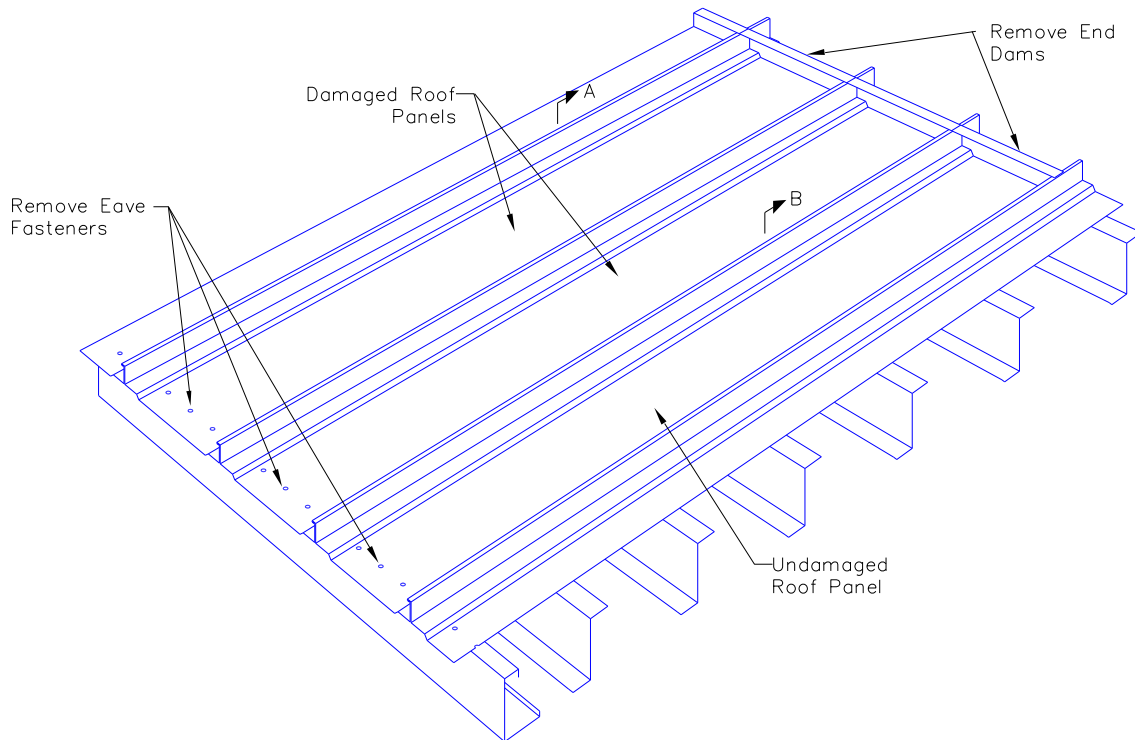

21.4 UN-SEAMING TOOL

The tool (shown below) is an economical but functional un-seaming tool.

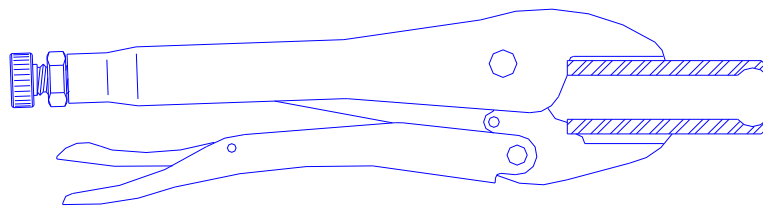

Un-Seaming Tool (Part No. 256294)

ZL-16® Roof System Installation Guide

21.5 UNFOLD STARTING AND FINISH SEAMS

Use the un-seaming tools to unfold the starting seam and finish seam. The seams must be unfolded continuous along the full length of the seams.

Note: The unfolding process is most effective when several tools are operated in unison at 8" to 12" spacing and in a coordinated progressive bending sequence.

Step 1 - Straddle the seam's top flange with the tool's blades as shown. Lock the blades in position as shown and bend the flange upward until there is sufficient clearance under the seam for step 2.

Step 2 - Straddle the seam's under-fold with the tool's blades. Lock the blades in position as shown and bend the under-fold outward.

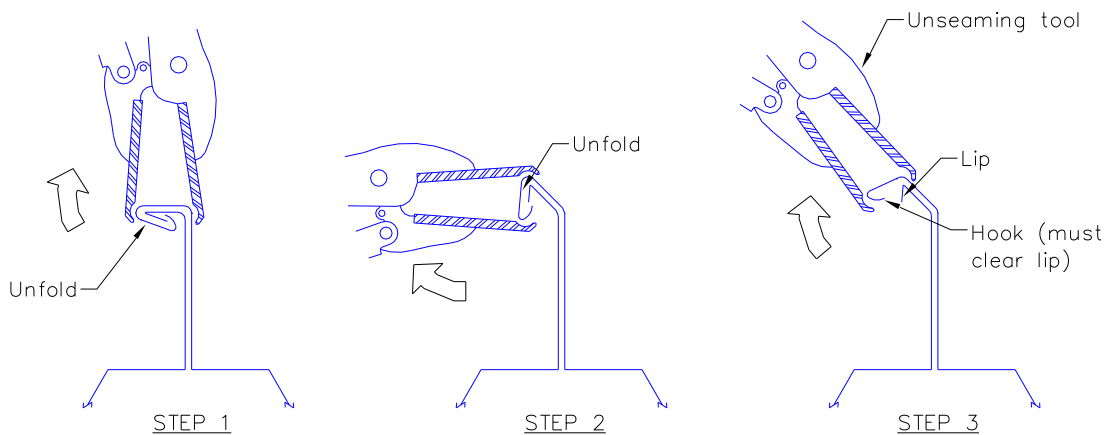

Step 3 - Continue to bend the under-fold outward until the seam is disengaged (the female hook clear must clear the male lip).

21.6 DISENGAGE THE STARTING AND FINISH SEAMS

At the starting seam, lift up the female edge of the damaged panel to disengage it from the male edge of the adjacent undamaged panel.

At the finish seam, lift up the female edge of the adjacent undamaged panel to disengage it from the male edge of the damaged panel and raise it to allow access to the panel clip fasteners. Remove the panel clip fasteners to free the clips and the edge of the damaged panel.

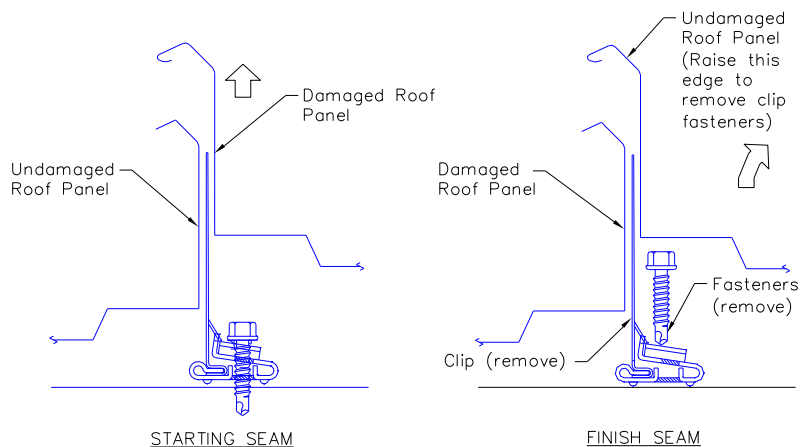

ZL-16® Roof System Installation Guide

21.7 REMOVE DAMAGED PANELS

Beginning at the finish seam, lift the free edge of the damaged roof panel and fold the panel over to provide access to the clip fasteners. Remove the fasteners to free the clips and the panel edge.

Note: During the removal of the damaged roof panels, the clips do not have to be detached from the roof panels.

Lift the panel edge and fold over on top of the previously folded panel. Continue removing the clip fasteners and folding the panels until all of the damaged panels are removed.

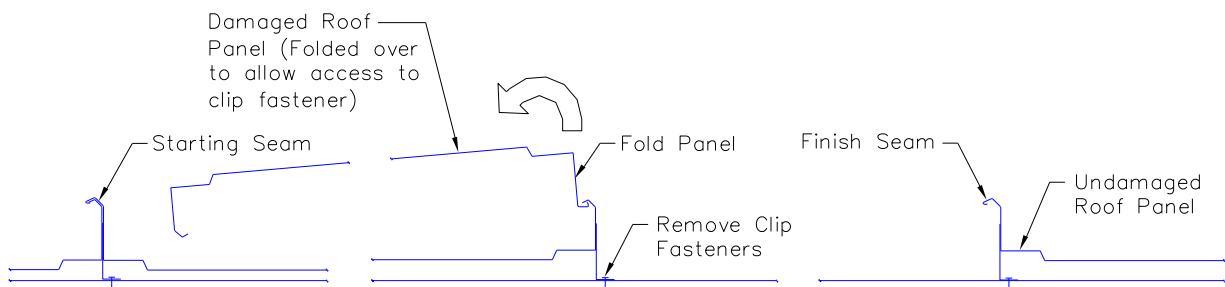

21.8 STARTING SEAM PREPARATION

At the starting seam, use the unseaming tool to reform the male edge on the adjacent undamaged panel. Reform this edge to the same configuration as on a new (unseamed) panel.

Step 1 - Straddle the male lip with the tool's blades and bend the lip outward as shown. The lip must bend out slightly, approximately 15°, beyond a right angle to the top flange.

Step 2 - Straddle the top flange and lip with the tool's blades and bend together downward as shown. Continue to bend downward until the top flange is horizontal.

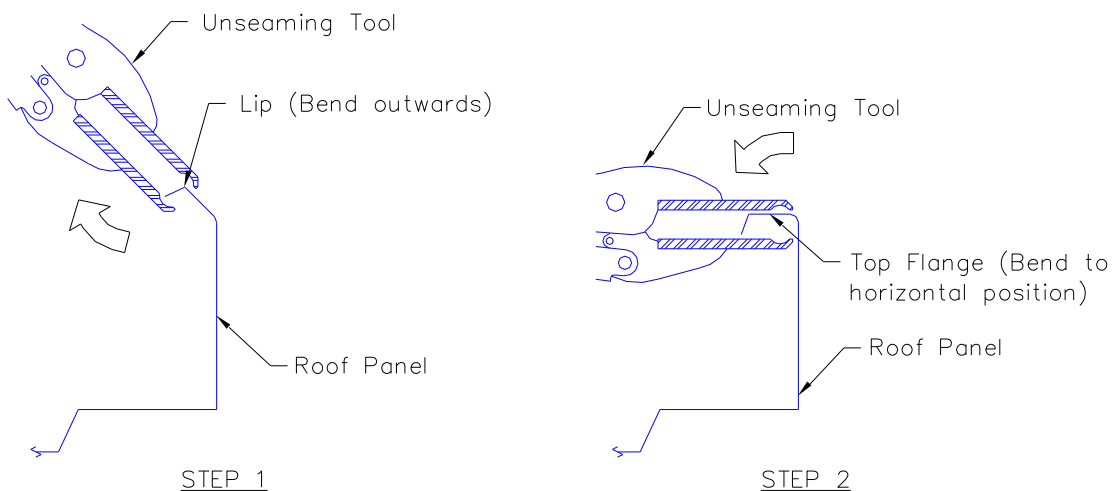

ZL-16® Roof System Installation Guide

21.9 FINISH SEAM PREPARATION

At the finish seam, use the un-seaming tool to open the female hook.

Step 1 - Straddle the female hook with the tool's blades and bend the female hook open (downward and outward) as shown.

Step 2 - Continue to bend outward until the hook is at a 90° bend.

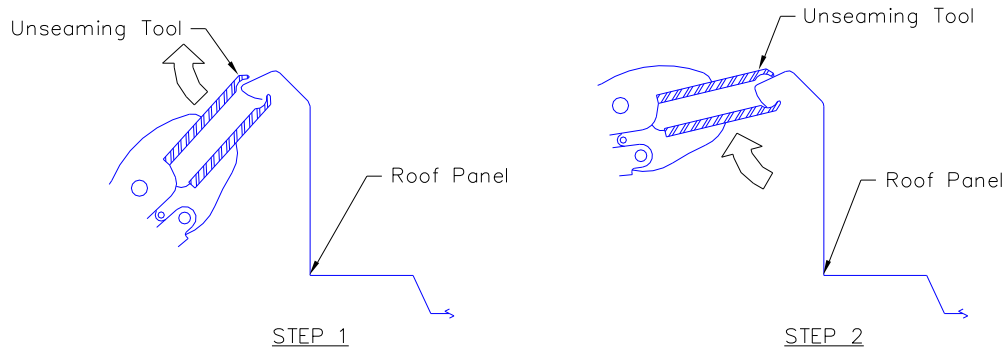

21.10 PREPARATION OF LAST REPLACEMENT PANEL

At the finish seam, use the un-seaming tool to reform the male edge of the last replacement panel.

Step 1 - Straddle the top flange and lip with the tool's blades and bend together upward as shown.

Step 2 - Continue to bend upward until the angle of the top flange matches the top flange on the adjacent undamaged panel (approximately 45°).

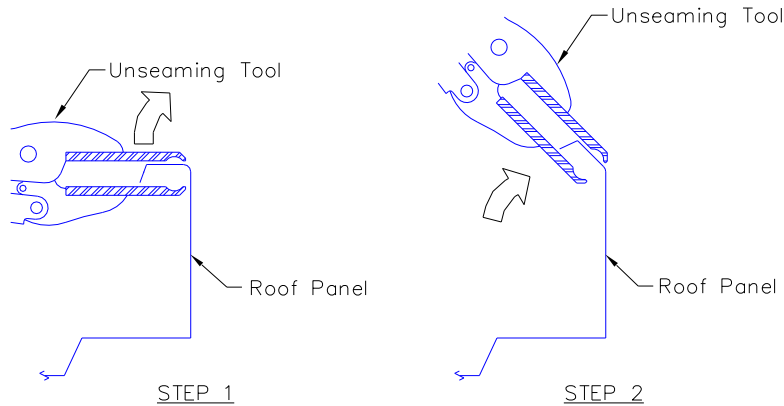

Step 3 - Apply seam sealant along the male panel as shown. Use gun grade mastic 3288023 to apply a 3/16 diameter bead of sealant continuous along the full length of the panel edge.

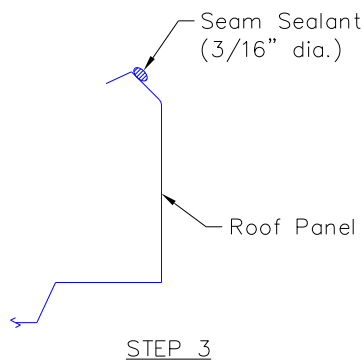

ZL-16® Roof System Installation Guide

21.11 INSTALL REPLACEMENT ROOF PANELS

Beginning at the starting seam, install the replacement roof panels. Install the panels in same manner as for a new roof (see Section 9.3).

Caution: During installation of the replacement panels, the proper panel coverage width must be maintained to assure that the last replacement panel will fit correctly at the finish seam.

To fit the final replacement panel at the finish seam, raise the adjacent undamaged panel to allow the installation of the replacement panel's clips and fasteners.

After the clips and fasteners are installed, lower the undamaged panel's female edge onto the replacement panel's male edge.

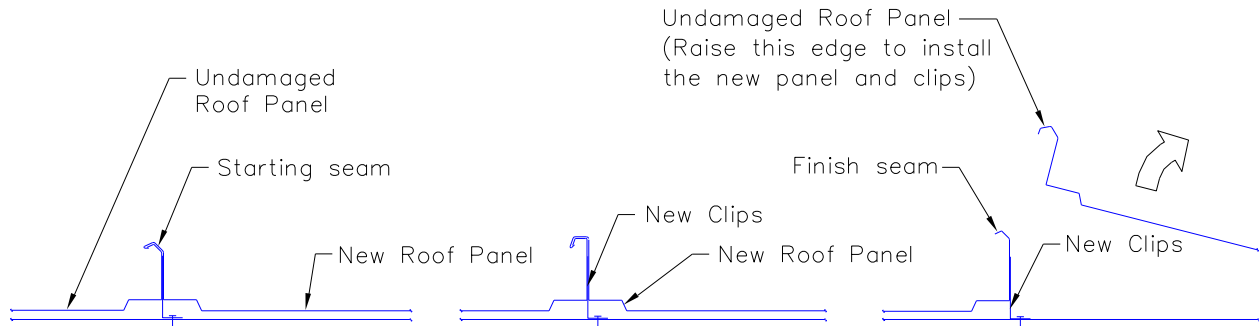

21.12 CLOSE THE FINISH SEAM

At the finish seam, use the un-seaming tool to close the female hook as shown in steps 1, 2 and 3. Before closing the hook, check the full length of the seam to assure that the hook will enclose the male lip.

21.13 FOLDING THE FINISH SEAM

If the seam is too open to allow operation of the manual seaming tool, it may be necessary to fold down the seam as shown in steps 1, 2 and 3.

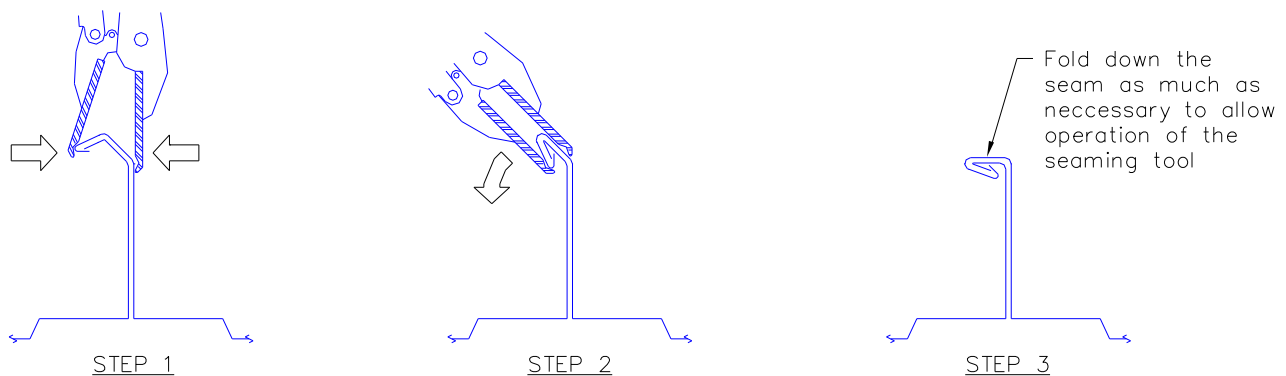

21.14 SEAMING THE FINISH SEAM

Before closing the finish seam with the motor seaming machine, use the manual seaming tool to close the seam at the eave and ridge ends and at each panel clip.

While closing the seam with the manual seaming tool, if the top flange of the seam is not horizontal tilt the handles of the tool to help bend the seam to the horizontal position.

6/08/15